

eAMBIT106

LOUDSPEAKERS

Surface Mount Loudspeaker

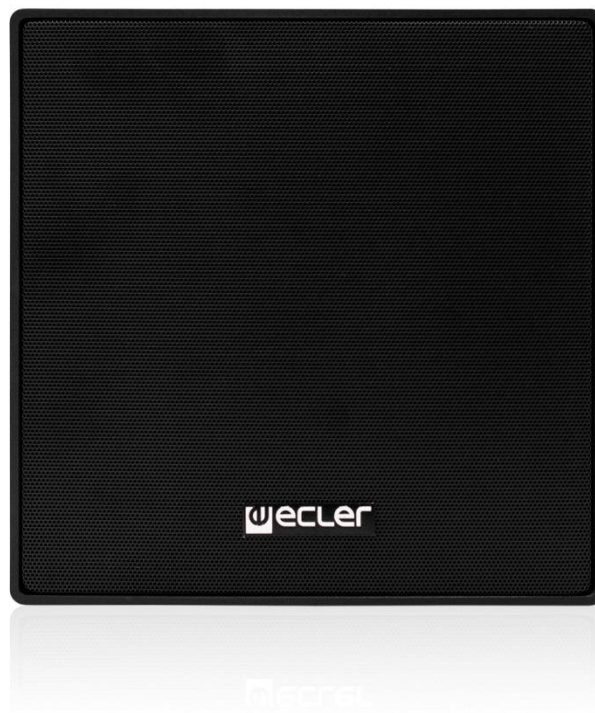

USER MANUAL

INDEX

1.	IMPORTANT REMARK	3
2.	IMPORTANT SAFETY INSTRUCTIONS	3
3.	IMPORTANT NOTE	5
4.	INTRODUCTION	5
5.	CONNECTIONS	6
6.	PLACEMENT AND MOUNTING	7
	<i>Edge / Corner:</i>	8
	<i>Wall / Ceiling:</i>	8
	<i>Other installation possibilities:</i>	9
7.	TECHNICAL CHARACTERISTICS.....	10

1. IMPORTANT REMARK



WARNING: SHOCK HAZARD - DO NOT OPEN

AVIS: RISQUE DE CHOC ÉLECTRIQUE - NE PAS OUVRIR



The lightning flash with arrowhead symbol, within an equilateral triangle, is intended to alert the user to the presence of uninsulated “dangerous voltage” within the product’s enclosure that may be of sufficient magnitude to constitute a risk of electric shock to persons.



The exclamation point within an equilateral triangle is intended to alert the user to the presence of important operating and maintenance (servicing) instructions in the literature accompanying the appliance.

WARNING (If applicable): The terminals marked with symbol of “” may be of sufficient magnitude to constitute a risk of electric shock. The external wiring connected to the terminals requires installation by an instructed person or the use of ready-made leads or cords.

WARNING: To prevent fire or shock hazard, do not expose this equipment to rain or moisture.

WARNING: An apparatus with Class I construction shall be connected to a mains socket-outlet with a protective earthing connection.

2. IMPORTANT SAFETY INSTRUCTIONS

1. Read these instructions.
2. Keep these instructions.
3. Heed all warnings.
4. Follow all instructions.
5. Do not use this apparatus near water.
6. Clean only with dry cloth.
7. Do not block any ventilation openings. Install in accordance with the manufacturer’s instructions.

8. Do not install near any heat sources such as radiators, heat registers, stoves, or other apparatus (including amplifiers) that produce heat.
9. Do not defeat the safety purpose of the polarized or grounding type plug. A polarized plug has two blades with one wider than the other. A grounding type plug has two blades and a third grounding prong. The wide blade or the third prong are provided for your safety. If the provided plug does not fit into your outlet, consult an electrician for replacement of the obsolete outlet.
10. Protect the power cord from being walked on or pinched particularly at the plugs, convenience receptacles, and at the point where they exit from the apparatus.
11. Only use attachments/accessories specified by the manufacturer.
12. Unplug the apparatus during lightening sorts or when unused for long periods of time.
13. Refer all servicing to qualified personnel. Servicing is required when the apparatus has been damaged in any way, such as power supply cord or plug is damaged, liquid has been spilled or objects have fallen into the apparatus, the apparatus has been exposed to rain or moisture, does not operate normally, or has been dropped.
14. Disconnecting from mains: Switching off the POWER switch all the functions and light indicators of the amplifier will be stopped, but fully disconnecting the device from mains is done unplugging the power cord from the mains input socket. For this reason, it always shall remain readily operable.
15. Equipment is connected to a socket-outlet with earthing connection by means of a power cord.
16. The marking information is located at the bottom of apparatus.
17. The apparatus shall not be exposed to dripping or splashing and that no objects filled with liquids, such as vases, shall be placed on apparatus.

NOTE: *This equipment has been tested and found to comply with the limits for a Class A digital device, pursuant to part 15 of the FCC Rules. These limits are designed to provide reasonable protection against harmful interference when the equipment is operated in a commercial environment. This equipment generates, uses, and can radiate radio frequency energy and, if not installed and used in accordance with the instruction manual, may cause harmful interference to radio communications. Operation of this equipment in a residential area is likely to cause harmful interference in which case the user will be required to correct the interference at his own expense.*



WARNING: This product must not be discarded, under any circumstance, as unsorted urban waste. Take to the nearest electrical and electronic waste treatment centre.

NEEC AUDIO BARCELONA, S.L. accepts no liability for any damage that may be caused to people, animal or objects due to failure to comply with the warnings above.

3. IMPORTANT NOTE

Thank you for choosing our Ecler **eAMBIT106 surface mount loudspeaker!**

It is **VERY IMPORTANT** to carefully read this manual and to fully understand its contents before any connection in order to maximize your use and get the best performance from this equipment.

To ensure optimal operation of this device, we strongly recommend that its maintenance be carried out by our authorised Technical Services.

Ecler **eAMBIT106** comes with a **3-year warranty**.

4. INTRODUCTION

The AMBIT range is more than just a line of acoustic cabinets for sound reproduction. AMBIT is the outcome of a study on the present and immediate future needs with respect to background music and announcements. Stores, large mall centers, schools, conference halls, hotels, industries, offices, museums, meeting rooms, hospitals, games areas... are just some of the most obvious places in which the AMBIT line can be directly applied. However, the Ecler design group has decided to go even further and, fully aware of the great variety of areas and situations in which acoustic cabinets can be used, has finally managed to fulfill the desires of the increasingly demanding installers and decorators:

- A series of discreet cabinets that will go unnoticed, blending into their surroundings. In this sense, the special shape of the AMBIT106/103, with their rear parts in the shape of a cut-off pyramid, enables the box to be installed flush with the wall in corner assemblies. Also, the box looks a lot smaller from the front than it actually is, as the back part is hidden from view.
- A unique product. No other similar box exists. The design is an exclusive Ecler design that is out of the ordinary, distinctive and, what is even more important, extremely adaptable to all kinds of situations. A two-way system with a treble loudspeaker that is concentric with the medium bass loudspeaker. The result is a square box that can be mounted in the most suitable position in terms of operation and aesthetics.
- Configurable. The AMBIT106 and 103 models have a switch that enables the cabinet to be configured depending on the purpose for which it is to be used. All the cabinets operate at high or low impedance and in this case, at different powers. Simple, fast and versatile.

- The AMBIT packaging contains everything you need to anchor the boxes in the required position. Each cabinet has two built-in guides on each of its 4 back sides (AMBIT106), which, in combination with the U-shaped “lira” support that is included, enables it to be placed in any position and direction. Allen wrenches, safety sling, safety screw; you will find everything included in each pair of AMBIT boxes to make them easy and quick to install.
- The versatility of these cabinets together with a large program of mechanical accessories make it possible to install systems by grouping together from two to as many boxes as are necessary to deal with virtually every need related to the reproduction of ambient music and announcement broadcasting.
- Reliability and Quality. Above all, AMBIT cabinets have a surprisingly good quality in terms of sound considering their dimensions. This is possible thanks to their special shape, which enables a higher volume to be achieved than what could be imagined. A power capacity of 50W RMS and 93dB SPL at 1W 1m is difficult to equal in enclosures with the same features and price.

5. CONNECTIONS

The AMBIT106 admits operation as high or low impedance. A 5-position switch is located at the back of the speaker and allows the selection of the operating mode. The first 4 switch positions are to be used in conjunction with a 100V line. Using a 100V speaker distribution system has various advantages regarding installation flexibility. First, different types of loudspeakers (different power handling or impedance) can be used simultaneously as required in different zones. On the other hand, the 100V line system minimizes power loss due to cable resistance, as usually long cable runs are required in large installations.

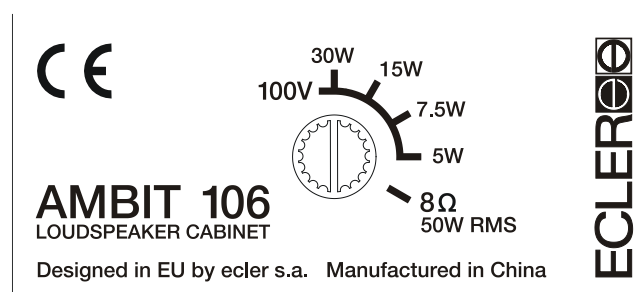

The AMBIT106 has 4 power handling levels for the 100V line. Depending on the intended use, the speaker output can be attenuated more or less. In the zones where sound intensity should be low, place the switch in the 5W or 7,5W position. If sound intensity should be high, place the switch at 15 or 30W.

The fifth switch position corresponds to low impedance operation with a maximum power capacity of 50W. When operating at low impedance you should always consider the limitations of the power amp when connecting several low-impedance speakers together. Impedances lower than 4Ω should be avoided. At low impedance operation and with long cable runs, the cables between the amplifier and the speakers should be as short as possible and have good quality.

ATTENTION: The AMBIT106 are shipped from factory with the switch in 100V/30W position. If it is connected to a low-impedance amplifier, the speaker will not be damaged, but will perform way below its full potential. If the speaker is accidentally connected to a 100V line in the 8Ω/50W position, it will be severely damaged.

Always respect polarity. All connections are on spring-loaded terminals.

6. PLACEMENT AND MOUNTING

Consider following general rules:

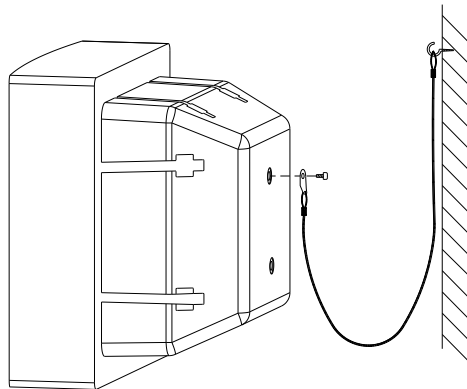

- Place the acoustic enclosures on solid and firm surfaces.
- No obstacles should stand between the enclosures and the audience.
- Although the speakers can be used outdoors, they should not be directly exposed to sunlight or rain.
- Always adjust the output sound pressure levels to the reproduction requirements. Despite their small size, they can produce significantly higher pressure levels than home speakers.

The AMBIT packaging contains everything you need to install the enclosure:

- Two U-shaped metal brackets (liras)
- Allen screws and nuts to fix the liras
- Screws and fixings for walls
- Screws and safety steel sling

- One angled Allen key

The two rails found on each of the four back sides of the AMBIT106 allow several installation positions. Speaker cables can be hidden from view by choosing an adequate mounting orientation. Although the inconspicuous AMBIT logo suggests mounting the unit with the input connectors on the upside and the selector switch on the downside, the enclosure can be mounted in any orientation because the high frequency driver is concentric and the adhesive logo can be positioned anywhere.

Following diagrams show the most common installation procedures for the AMBIT106:

Edge / Corner:

The “lira” is mounted horizontally between two walls. In this case a 90° vertical tilt can be achieved, and by shifting the screws that are attached to the enclosure, up to 7,5° horizontal adjustment range is available.

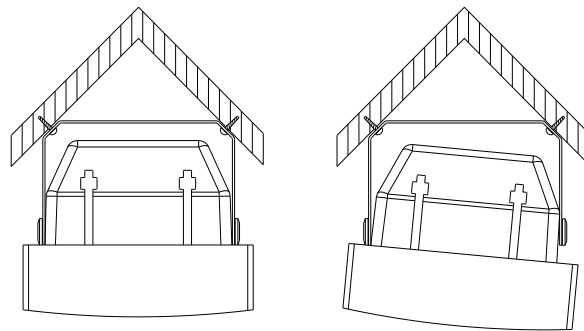

Wall / Ceiling:

The “lira” is mounted either horizontally or vertically, depending on the required tilt angle. The tilt amount is 90° in the perpendicular direction to the “lira”, and 7,5° by shifting the enclosure attachment screws as in the previous example.

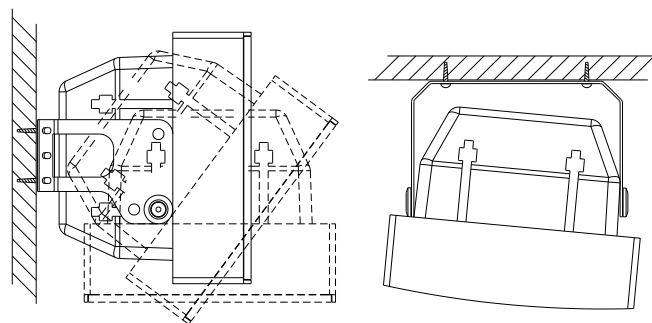

Other installation possibilities:

The AMBIT106 has two embedded nuts on their back side at a normalized distance of 60mm, which not only serve as safety point for the steel sling, but also allow attachment to standard wall mounting supports.

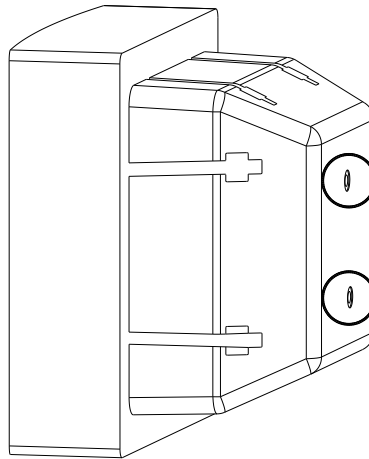

Ecler offers a wide range of mechanical accessories that can be used to group several AMBIT106, thus enhancing their versatility even more. Please refer to your Ecler distributor or visit www.ecler.com for all existing possibilities.

7. TECHNICAL CHARACTERISTICS

eAMBIT106

System	
Effective frequency range ¹	110Hz - 20kHz
Coverage angle ²	120°x120° (HxV)
Power handling	50 W RMS / 200 W Peak
Sensitivity ³	93 dB (1W/1m)
Maximum SPL ⁴	110 dB continuous / 116 dB peak
Power options	70/100V: 30W / 15W / 7,5W / 5W / 8Ω
Recommended amplifier power	100 W RMS
Transducers	
Ways	2
Low frequency driver	6,5" woofer
High frequency driver	1 tweeter"
Nominal impedance	8Ω
Physical	
Connection type	Spring loaded input terminals
Environmental	IP54 rated
Mounting system	Cabinet
Included accessories	Includes on-wall hardware, safety sling, screws and wrench for fast installation
Finished colour	White (RAL 9016) or black (RAL 9005)
Dimensions (WxHxD)	Without accessories: 210 x 210 x 160 mm / 8.27 x 8.27 x 6.30 in.
Weight	2.75 kg / 6.06 lb

¹3dB below the sound pressure level at specified sensitivity

²6dB below the sound pressure level than that at the direction of maximum level, Max. angle between 1 kHz and 4 kHz.

³Measured on-axis, far field and referenced to 1 meter by inverse square law. Average from 100 Hz to 10 kHz.

⁴Calculated from sensitivity and power handling specifications, exclusive of power compression



All product characteristics are subject to variation due to production tolerances. **NEEC AUDIO BARCELONA S.L.** reserves the right to make changes or improvements in the design or manufacturing that may affect these product specifications.

For technical queries contact your supplier, distributor or complete the contact form on our website, in [Support / Technical requests](#).

Motors, 166-168 08038 Barcelona - Spain - (+34) 932238403 | information@ecler.com | www.ecler.com