

eMOTUS50D

SURFACE MOUNT CABINETS

Outdoor Loudspeaker



PRODUCT OVERVIEW

eMOTUS50D is a 5" loudspeaker cabinet ready for outdoor installation. A professional and compact loudspeaker, cost-effective and with a unique design that will easily fit in a massive number of applications: theme parks, gardens, nature parks and urban spaces, leisure, health and sport centres, residential buildings, outdoor areas, etc. Available in black and white colour.

KEY FEATURES

- 2-way cabinet
- 5" woofer and 1" coaxial tweeter
- 40WRMS @ 8Ω
- Power selector 100V: 30 / 15 / 7,5 / 3,75W & 8Ω
- Power selector 70V: 15 / 7.5 / 3.75 / 1,8W & 8Ω
- Max SPL (Peak) :107dB
- Effective frequency range (-10dB): 75 – 20kHz
- Coverage angle (HxV): 150°x150°
- Outdoor design: IP65 rated
- Back rubber cover for connections
- Euroblock connections
- Material: ABS cabinet, aluminium grill, ABS bracket
- Includes wall bracket and security steel cable
- Available in black and white colour
- EASE file available

APPLICATIONS

- Commercial
- Education
- Corporate
- Sports and wellness
- Leisure

ACCESSORIES AND COMPATIBLE DEVICES

- PCS124



PCS124

TECHNICAL SPECIFICATIONS

eMOTUS50D

System	
Effective frequency range ¹	75 Hz - 20 kHz (-10dB)
Coverage angle ²	150° x 150° (HxV)
Power handling	40W RMS / 160W Peak
Sensitivity ³	85dB (1W/1m)
Maximum SPL ⁴	101dB continuous / 107dB peak
Power options	100V: 30 / 15 / 7,5 / 3,75W & 8Ω 70V: 15 / 7.5 / 3.75 / 1,8W & 8Ω
Recommended amplifier power	80W (8Ω)
Transducers	
Ways	2-ways, full range
Low frequency driver	5" woofer
High frequency driver	1" coaxial tweeter
Nominal impedance	8Ω
Physical	
Connection type	2-terminal Euroblock connector (Input)
Power type selector	Selectable transformer tap
Installation options	Surface, desktop
Environmental	IP65 rated
Enclosure material	ABS cabinet
Grille material	Aluminium grille
Mounting system	ABS bracket
Finished color	White (RAL 9003) or black (RAL 9005)
Included accessories	Wall-mount bracket, adhesive legs, back rubber cover & security steel cable
Optional accessories	PCS124 cluster-mount system
Dimensions	Not including brackets (HxWxD): 180 x 173 x 181mm / 7.1" x 6.8" x 7.1" Including brackets (HxWxD): 180 x 173 x 248mm / 7.1" x 6.8" x 9.8"
Weight	Not including brackets: 2,2 kg. / 4.9 lb. Including brackets: 2,5 kg. / 5.5 lb.
Pieces per box	2 units with included accessories
Shipping dimensions	HxWxD: 220 x 230 x 460mm / 8.7" x 9.1" x 18.1"
Shipping weight	5,0 kg. / 11.0 lb.

¹10dB below the sound pressure level at specified sensitivity

²6dB below the sound pressure level than that at the direction of maximum level, Average from 1 kHz to 4 kHz.

³Measured on-axis, 2,83V, far field and referenced to 1 meter by inverse square law. Average from 100 Hz to 10 kHz.

⁴Calculated from sensitivity and power handling specifications, exclusive of power compression

FREQUENCY RESPONSE ON-AXIS

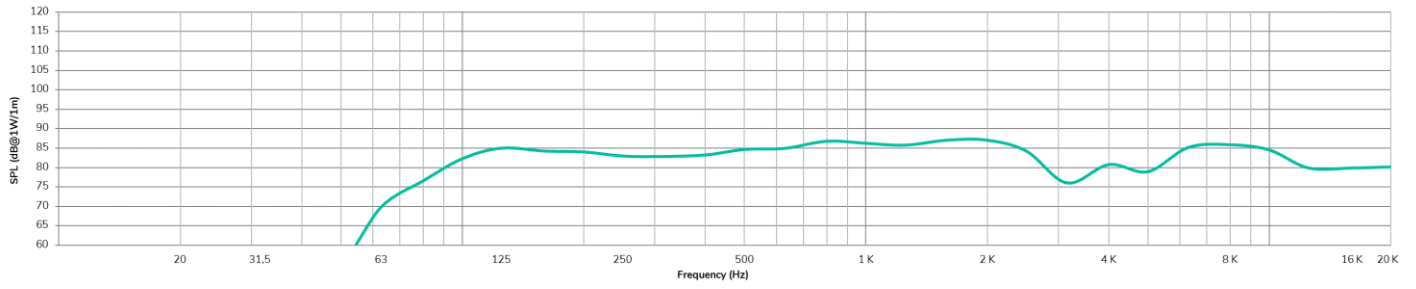

POLAR DIAGRAMS

CONICAL

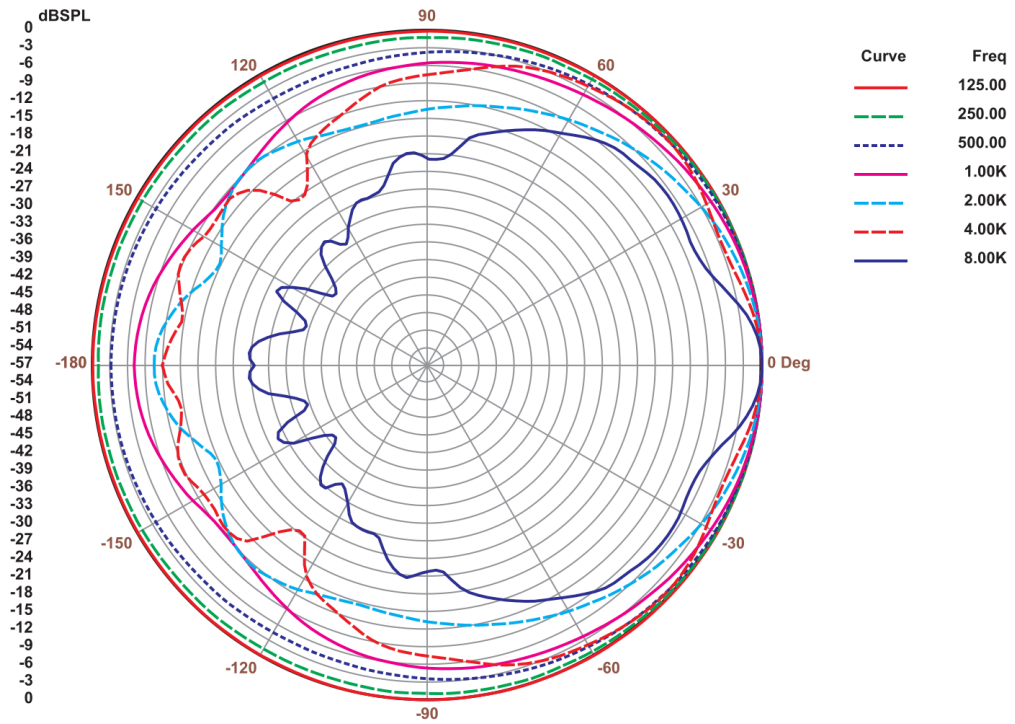

MECHANICAL DIAGRAMS

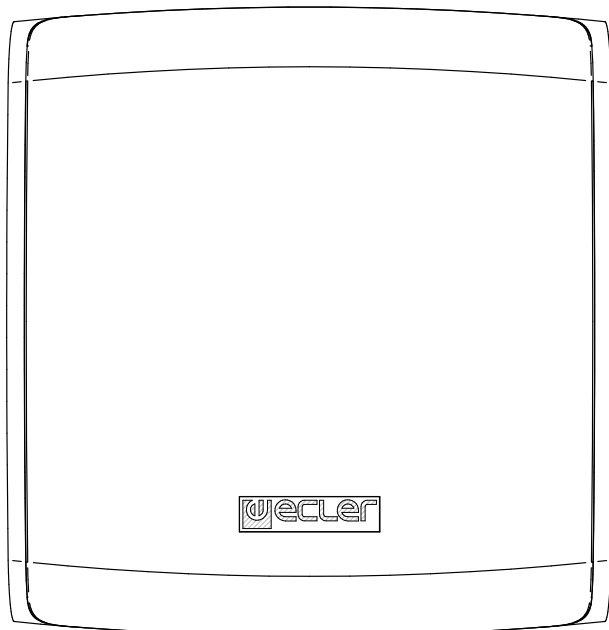

FRONT

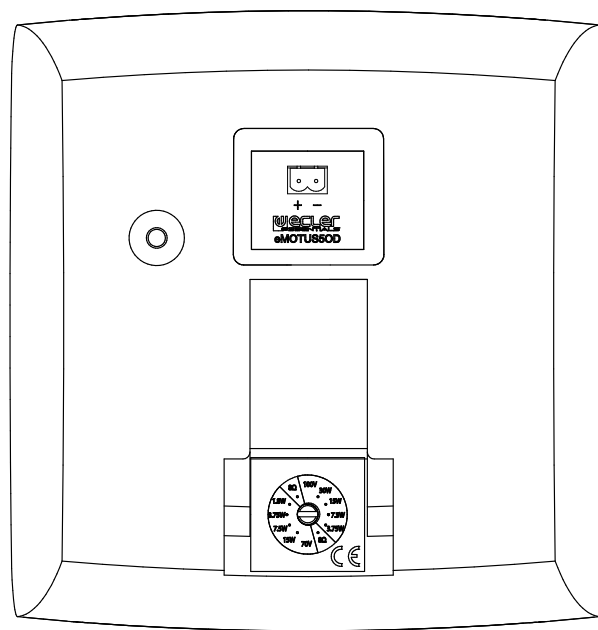

REAR

WALL BRACKET MOUNTING DIAGRAM

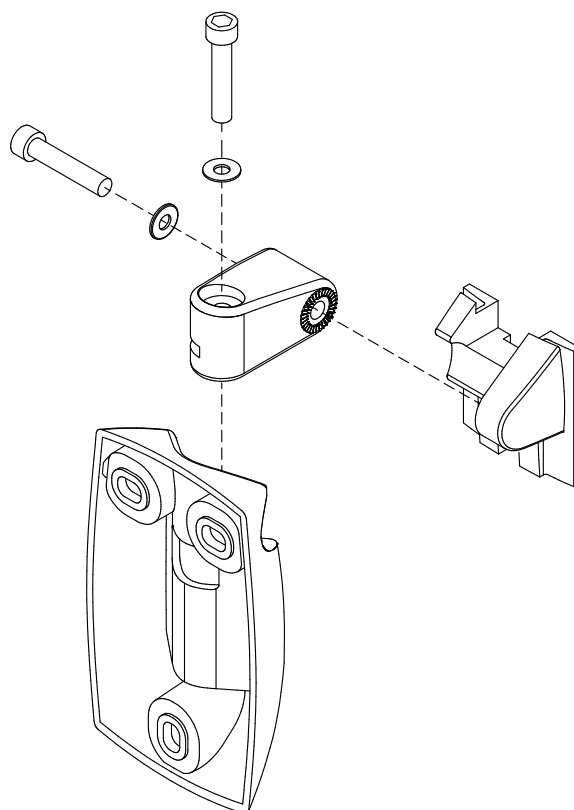



All product characteristics are subject to variation due to production tolerances. **NEEC AUDIO BARCELONA S.L.** reserves the right to make changes or improvements in the design or manufacturing that may affect these product specifications.

For technical requests address to your supplier, distributor or fill the contact form in our website, at [Support / Technical Request](#).

Motors, 166-168 08038 Barcelona - Spain - (+34) 932238403 | information@ecler.com | www.ecler.com