

eMOTUS80D

WALL SPEAKERS

Outdoor Passive Speaker



USER MANUAL

INDEX

1. IMPORTANT REMARK	3
2. IMPORTANT SAFETY INSTRUCTIONS	3
3. IMPORTANT NOTE.....	5
4. INTRODUCTION.....	5
5. MAIN FEATURES	5
6. CABLE CONNECTIONS	6
7. LOCATION, ASSEMBLY AND START-UP	7
8. REAR PANEL.....	9
9. TECHNICAL CHARACTERISTICS	10
10. PACKAGE CONTENTS	10

1. IMPORTANT REMARK



WARNING: SHOCK HAZARD - DO NOT OPEN
AVIS: RISQUE DE CHOC ÉLECTRIQUE - NE PAS OUVRIR



The lightning flash with arrowhead symbol, within an equilateral triangle, is intended to alert the user to the presence of uninsulated “dangerous voltage” within the product’s enclosure that may be of sufficient magnitude to constitute a risk of electric shock to persons.



The exclamation point within an equilateral triangle is intended to alert the user to the presence of important operating and maintenance (servicing) instructions in the literature accompanying the appliance.

WARNING (If applicable): The terminals marked with symbol of “” may be of sufficient magnitude to constitute a risk of electric shock. The external wiring connected to the terminals requires installation by an instructed person or the use of ready-made leads or cords.

WARNING: To prevent fire or shock hazard, do not expose this equipment to rain or moisture.

WARNING: An apparatus with Class I construction shall be connected to a mains socket-outlet with a protective earthing connection.

2. IMPORTANT SAFETY INSTRUCTIONS

1. Read these instructions.
2. Keep these instructions.
3. Heed all warnings.
4. Follow all instructions.
5. Do not use this apparatus near water.
6. Clean only with dry cloth.
7. Do not block any ventilation openings. Install in accordance with the manufacturer’s instructions.

8. Do not install near any heat sources such as radiators, heat registers, stoves, or other apparatus (including amplifiers) that produce heat.
9. Do not defeat the safety purpose of the polarized or grounding type plug. A polarized plug has two blades with one wider than the other. A grounding type plug has two blades and a third grounding prong. The wide blade or the third prong are provided for your safety. If the provided plug does not fit into your outlet, consult an electrician for replacement of the obsolete outlet.
10. Protect the power cord from being walked on or pinched particularly at the plugs, convenience receptacles, and at the point where they exit from the apparatus.
11. Only use attachments/accessories specified by the manufacturer.
12. Unplug the apparatus during lightning sorts or when unused for long periods of time.
13. Refer all servicing to qualified personnel. Servicing is required when the apparatus has been damaged in any way, such as power supply cord or plug is damaged, liquid has been spilled or objects have fallen into the apparatus, the apparatus has been exposed to rain or moisture, does not operate normally, or has been dropped.
14. Disconnecting from mains: Switching off the POWER switch all the functions and light indicators of the amplifier will be stopped, but fully disconnecting the device from mains is done unplugging the power cord from the mains input socket. For this reason, it always shall remain readily operable.
15. Equipment is connected to a socket-outlet with earthing connection by means of a power cord.
16. The marking information is located at the bottom of apparatus.
17. The apparatus shall not be exposed to dripping or splashing and that no objects filled with liquids, such as vases, shall be placed on apparatus.

NOTE: *This equipment has been tested and found to comply with the limits for a Class A digital device, pursuant to part 15 of the FCC Rules. These limits are designed to provide reasonable protection against harmful interference when the equipment is operated in a commercial environment. This equipment generates, uses, and can radiate radio frequency energy and, if not installed and used in accordance with the instruction manual, may cause harmful interference to radio communications. Operation of this equipment in a residential area is likely to cause harmful interference in which case the user will be required to correct the interference at his own expense.*



WARNING: This product must not be discarded, under any circumstance, as unsorted urban waste. Take to the nearest electrical and electronic waste treatment centre.

NEEC AUDIO BARCELONA, S.L. accepts no liability for any damage that may be caused to people, animal or objects due to failure to comply with the warnings above.

3. IMPORTANT NOTE

Thank you for choosing our **outdoor passive speaker eMOTUS80D!**

It is **VERY IMPORTANT** to carefully read this manual and to fully understand its contents before any connection in order to maximize your use and get the best performance from this equipment.

To ensure optimal operation of this device, we strongly recommend that its maintenance be carried out by our authorised Technical Services.

Ecler **eMOTUS80D** comes with a **3-year warranty**.

4. INTRODUCTION

eMOTUS80D is an 8" loudspeaker designed for outdoor installation. A compact and professional loudspeaker, with high performance and at a very attractive cost. Its fantastic performance and exclusive design means that it can be easily integrated into a large number of applications: theme parks, urban spaces, gardens, etc. Available in white and black.

5. MAIN FEATURES

- Two-way speaker, an 8" woofer and a 1" tweeter
- 100WRMS @ 8Ω
- Power selector: 60 / 30 / 15 / 7,5 W for 70/100V line (+ 3,75W position for 70V line) and 8Ω position
- Designed for exteriors
- IP65 Rating
- Rubber cover to protect rear connections
- Available in white (RAL 9003) and black (RAL 9005)

6. CABLE CONNECTIONS

The eMOTUS8OD supports high or low impedance operation. In this sense, its rear panel has a 5-position switch to select its working mode. The first 4 positions allow the system to work in high impedance and the fifth in low impedance. (*) The 4 positions of the 100 V line power selector will allow you to configure the maximum power that each unit will work with. Thus, in areas where a low sound level is desired, the lower positions 7,5 or 15 W will be used; while in areas where a higher level is desired, the upper positions 30 or 60 W will be used. If the loudspeaker is used in 70V installations, the 3,75W position can also be used. In the case of 50V installations, the positions corresponding to the 100V position will be reduced by a quarter.

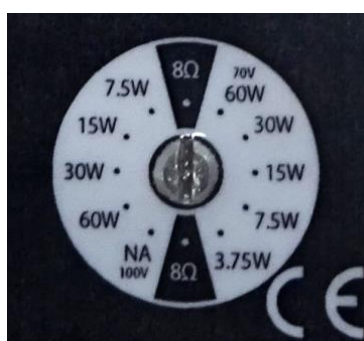

The fifth position corresponds to low impedance operation (100 WRMS @8Ω). If you choose this configuration, you must take into account the limitations of the amplifier when connecting multiple speakers to its output, especially if the impedance of the set drops below 4Ω. It is also important that the connection cable between the amplifier outputs and the speakers be of good quality and as short as possible; this is especially important when the distances to be covered are large and the impedance of the speakers is low.

(*) Note: The 100V/70V line speaker distribution system historically arose from the technical need to mix loudspeakers of different impedances and/or powers on the same line or amplifier channel, all without having to worry about the total impedance of the resulting set. Additionally, this solution allows to use, with minimum power losses, long cable runs and of a significantly lower section than the one usually used in the low impedance installation.

WARNING! eMOTUS80D is supplied as standard with the switch in the 100V/60W position. **If you accidentally connect the system to a low impedance amplifier, it will not cause any damage to the loudspeaker but it will perform well below its performance. If you accidentally connect the loudspeaker to a 100V network with the switch in a 8Ω position, it will be severely damaged.**

7. LOCATION, ASSEMBLY AND START-UP

On the packaging of the eMOTUS80D you will find everything you need to complete the installation of the unit.

The following general rules shall be observed:

- Always install the unit on solid and firm surfaces.
- For good sound reproduction there must be no obstacle between the speakers and the audience.
- Adapt the sound pressure levels to the needs of reproduction.

On the packaging of the eMOTUS8D you will find everything you need to complete the installation of the two units:

- Two articulated wall mounting brackets
- 5mm Allen key
- Two metal security cords (slings) against possible detachments, with their corresponding screws and fixing washers.
- Two two-terminal Euroblock connectors
- 8 adhesive feet for tabletop placement
- Quick User Guide
- Warranty Card

Wall installation procedure:

1. Drill three 6 mm holes in the wall, matching the position of the holes in the bracket.
2. Insert three 6 mm wall plugs into them.
3. Fasten the safety sling on the speaker using the provided screw and hook up the sling's carabiner-ended side to a secure anchor point.
4. Place the bracket in place, previously passing the speaker line and speaker wire through the square hole in the bracket. Attach the bracket to the wall. Connect the speaker cable to the connector on the back of the box using the supplied Euroblock connector. Pay attention to the correct polarity of the terminals and that the cable passes through the square-shaped hole in the bracket. It is recommended that the supplied protective cover be fitted when the speaker is installed outdoors.

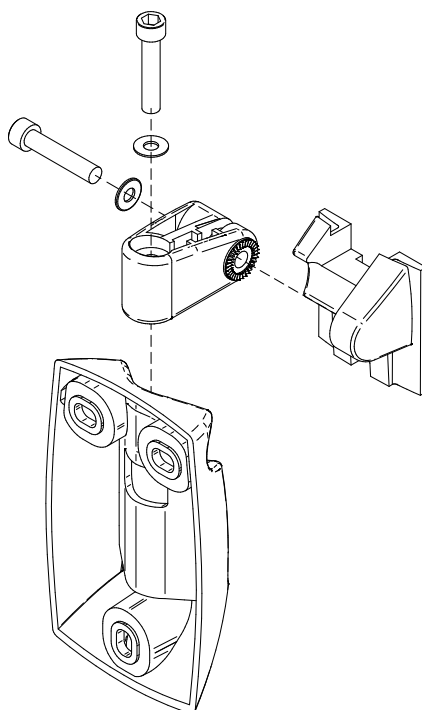

5. Place the speaker in its final position by sliding it vertically downward so that the guide on its back side matches the guide on the bracket.
6. Hold the safety wire at the back of the speaker so that the speaker does not accidentally fall and cause damage to property and/or personnel.
7. Orient the loudspeaker to the desired position on the vertical and horizontal axes. Tighten the Allen screws on the bracket to fix this position on both axes.
8. Set the power selector to the desired position.

8. REAR PANEL

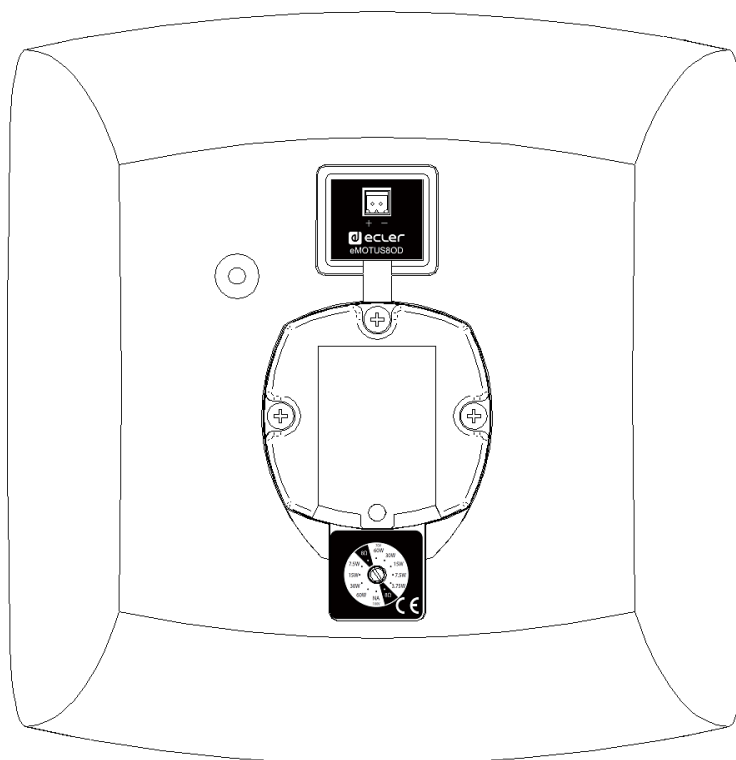

1. 2-pin Euroblock connector
2. Anchorage point of the safety cable
3. Power selector

9. TECHNICAL CHARACTERISTICS

eMOTUS80D

System	
Effective frequency range ¹	65 Hz-20 kHz
Coverage angle ²	142°x142° (HxV)
Power handling	100 W RMS / 400 W Peak
Sensitivity ³	88 dB (1W/1m)
Maximum SPL ⁴	108 db continuous / 114 dB peak
Recommended amplifier power	200 W RMS
Transducers	
Ways	2
Low frequency driver	8" woofer
High frequency driver	1 tweeter"
Nominal impedance	8Ω
Physical	
Environmental	IP65 rated
Enclosure material	ABS
Grille material	Aluminium
Mounting system	Cabinet
Included accessories	Wall-mount bracket, security steel cable
Finished colour	White (RAL 9003) or black (RAL 9005)
Dimensions (WxHxD)	Not including brackets: 268 x 242 x 264 mm / 10.56 x 9.53 x 10.4 in. Including brackets: 268 x 327 x 264 mm / 10.56 x 12.87 x 10.4 in.
Weight	4.25 kg / 9.37 lb including accessories: 4.75 kg / 10.47 lb

¹10dB below the sound pressure level at specified sensitivity

²6dB below the sound pressure level than that at the direction of maximum level, Max. angle between 1 kHz and 4 kHz.

³Measured on-axis, far field and referenced to 1 meter by inverse square law. Average from 100 Hz to 10 kHz.

⁴Calculated from sensitivity and power handling specifications, exclusive of power compression

10. PACKAGE CONTENTS

- 2 x eMOTUS80D speakers
- 2 x articulated wall mounting brackets
- 5mm Allen key
- 2 x metal security hoses against possible detachment, with their corresponding screws and fixing washers
- 8 x Adhesive feet for desktop speaker placement
- Weatherproof rear connection covers
- Quick User Guide
- Warranty Card



All product characteristics are subject to variation due to production tolerances. **NEEC AUDIO BARCELONA S.L.** reserves the right to make changes or improvements in the design or manufacturing that may affect these product specifications.

For technical queries contact your supplier, distributor or complete the contact form on our website, in [Support / Technical requests](#).

Motors, 166-168 08038 Barcelona - Spain - (+34) 932238403 | information@ecler.com | www.ecler.com