

LABI1 Series

CABINET LOUDSPEAKERS

Compact PA Systems



USER MANUAL

INDEX

1. IMPORTANT REMARK	4
2. IMPORTANT SAFETY INSTRUCTIONS	4
3. IMPORTANT NOTE.....	6
4. INTRODUCTION.....	6
5. MODELS & ACCESORIES	7
5.1. LOUDSPEAKERS	7
5.1.1. LABI1-SB18p.....	7
5.1.2. LABI1-SB18.....	7
5.1.3. LABI1-C100i.....	7
5.2. LOUDSPEAKERS MOUNTING HARDWARE	8
LABI1-SAC.....	8
LABI1-CAC.....	8
LABI1-TBC	8
LABI1-WBC	8
LABI1-PBC	8
LABI1-HBC.....	8
LABI1-ODCNX.....	8
5.3. ACCESSORIES.....	8
LABI1-CFC.....	8
LABI1-SWK.....	8
LABI1-SPC.....	8
6. START UP AND CONNECTION.....	9
6.1. CONNECTIONS	9
6.2. CONFIGURATION PANEL.....	10

7. INSTALLATION AND CONFIGURATION SYSTEMS	11
7.1. LABI1-C100i: ACOUSTIC CENTRE.....	11
7.2. ACTIVE LOUDSPEAKERS SYSTEMS.....	12
7.2.1. PRESETS	12
7.2.2. LOUDSPEAKERS CONFIGURATION	13
7.3. PASSIVE LOUDSPEAKERS SYSTEMS.....	15
7.4. ACCESSORIES INSTALLATION.....	16
7.4.1. LABI1-SAC (Subwoofer – Adapter –Column).....	16
7.4.2. LABI1-CAC (Column – Adapter – Column).....	16
7.4.3. LABI1-TBC (Truss mount accessory).....	17
7.4.4. LABI1-WBC (Wall mount accessory).....	17
7.4.5. LABI1-PBC (Pole mount accessory).....	18
7.4.6. LABI1-ODCNX (Outdoor kit)	18
7.4.7. LABI1-HBC (Horizontal mount accessory).....	18
8. REAR PANEL.....	19
8.1. LABI1-SB18p.....	19
8.2. LABI1-SB18.....	20
8.3. LABI1-C100i.....	21
9. TECHNICAL SPECIFICATIONS.....	23
9.1. LABI1-SB18p.....	23
9.2. LABI1-SB18.....	24
9.3. LABI1-C100i.....	25

1. IMPORTANT REMARK



WARNING: SHOCK HAZARD - DO NOT OPEN
AVIS: RISQUE DE CHOC ÉLECTRIQUE - NE PAS OUVRIR



The lightning flash with arrowhead symbol, within an equilateral triangle, is intended to alert the user to the presence of uninsulated “dangerous voltage” within the product’s enclosure that may be of sufficient magnitude to constitute a risk of electric shock to persons.



The exclamation point within an equilateral triangle is intended to alert the user to the presence of important operating and maintenance (servicing) instructions in the literature accompanying the appliance.

WARNING (If applicable): The terminals marked with symbol of “” may be of sufficient magnitude to constitute a risk of electric shock. The external wiring connected to the terminals requires installation by an instructed person or the use of ready-made leads or cords.

WARNING: To prevent fire or shock hazard, do not expose this equipment to rain or moisture.

WARNING: An apparatus with Class I construction shall be connected to a mains socket-outlet with a protective earthing connection.

2. IMPORTANT SAFETY INSTRUCTIONS

1. Read these instructions.
2. Keep these instructions.
3. Heed all warnings.
4. Follow all instructions.
5. Do not use this apparatus near water.
6. Clean only with dry cloth.
7. Do not block any ventilation openings. Install in accordance with the manufacturer’s instructions.

8. Do not install near any heat sources such as radiators, heat registers, stoves, or other apparatus (including amplifiers) that produce heat.
9. Do not defeat the safety purpose of the polarized or grounding type plug. A polarized plug has two blades with one wider than the other. A grounding type plug has two blades and a third grounding prong. The wide blade or the third prong are provided for your safety. If the provided plug does not fit into your outlet, consult an electrician for replacement of the obsolete outlet.
10. Protect the power cord from being walked on or pinched particularly at the plugs, convenience receptacles, and at the point where they exit from the apparatus.
11. Only use attachments/accessories specified by the manufacturer.
12. Unplug the apparatus during lightning sorts or when unused for long periods of time.
13. Refer all servicing to qualified personnel. Servicing is required when the apparatus has been damaged in any way, such as power supply cord or plug is damaged, liquid has been spilled or objects have fallen into the apparatus, the apparatus has been exposed to rain or moisture, does not operate normally, or has been dropped.
14. Disconnecting from mains: Switching off the POWER switch all the functions and light indicators of the amplifier will be stopped, but fully disconnecting the device from mains is done unplugging the power cord from the mains input socket. For this reason, it always shall remain readily operable.
15. Equipment is connected to a socket-outlet with earthing connection by means of a power cord.
16. The marking information is located at the bottom of apparatus.
17. The apparatus shall not be exposed to dripping or splashing and that no objects filled with liquids, such as vases, shall be placed on apparatus.

NOTE: *This equipment has been tested and found to comply with the limits for a Class A digital device, pursuant to part 15 of the FCC Rules. These limits are designed to provide reasonable protection against harmful interference when the equipment is operated in a commercial environment. This equipment generates, uses, and can radiate radio frequency energy and, if not installed and used in accordance with the instruction manual, may cause harmful interference to radio communications. Operation of this equipment in a residential area is likely to cause harmful interference in which case the user will be required to correct the interference at his own expense.*



WARNING: This product must not be discarded, under any circumstance, as unsorted urban waste. Take to the nearest electrical and electronic waste treatment centre.

NEEC AUDIO BARCELONA, S.L. accepts no liability for any damage that may be caused to people, animal or objects due to failure to comply with the warnings above.

3. IMPORTANT NOTE

Thank you for choosing our Ecler **LABI1 series cabinet loudspeakers!**

It is **VERY IMPORTANT** to carefully read this manual and to fully understand its contents before any connection in order to maximize your use and get the best performance from this equipment.

To ensure optimal operation of this device, we strongly recommend that its maintenance be carried out by our authorised Technical Services.

Ecler **LABI1 series** comes with a **3-year warranty**.

4. INTRODUCTION

Ecler LABI ONE SERIES has been specially designed to provide a compact loudspeakers system solution for mobile and fixed installations in environments in need of high output, easy and quick installation, and excellent sound quality. The variety of products and accessories allows several different configurations, depending on the needs required.

The series is composed by 3 loudspeakers: an active 18" subwoofer with 18 different DSP configurations, a passive 18" subwoofer, and a column loudspeaker featuring 12x3" transducers. Moreover, the series include several mounting accessories, allowing an easy installation of the C100i loudspeaker on multiple surfaces (on the subwoofer, on wall, pole, truss, etc), as well as an accessory to make the column ready for outdoor applications.

5. MODELS & ACCESORIES

The following list provides the main features of the LABI ONE series models and accessories.

5.1. LOUDSPEAKERS

5.1.1. LABI1-SB18p

- Powered subwoofer enclosure designed to be part on a loudspeaker system together with LABI1-C100i
- 1x18" speaker with 3" voice coil
- Amp. Power: 2400W Class D
- LF amplifier: 1x1200W
- Speaker output amplifier: 1x1200W@8Ω / 2x600W@4Ω
- Max. SPL: 132dB
- 2 x Input connectors: XLR3 balanced (+ 2 x XLR outputs)
- 2 x Output connector to satellites: Speakon®
- Includes 120cm Speakon®-Speakon® cable

5.1.2. LABI1-SB18

- 18" passive subwoofer
- 1x18" speaker with 3" voice coil
- 500WRMS@8 Ω (1200W max. power)
- Sensitivity (1W/1m): 98dB
- Input connector: Speakon®

5.1.3. LABI1-C100i

- 1m column loudspeaker
- 12x3" speaker with 0,75" voice coil
- 300WRMS@8 Ω (600W max. power)
- Sensitivity (1W/1m): 96dB
- Input connectors: Speakon® NL4MP + 2-pin Euroblock (+LINK connectors)
- Ready for outdoor applications (adding LABI1-ODCNX accessory)
- Includes 60cm Speakon®-Speakon® cable

5.2. LOUDSPEAKERS MOUNTING HARDWARE

<u>LABI1-SAC</u>	Subwoofer-adapter-column, to install the LABI1-C100i satellite loudspeaker on LABI1-SB18p
<u>LABI1-CAC</u>	Column-adapter-column, to connect vertically two LABI1-C100i column loudspeakers. Includes 60cm Speakon®-Speakon® cable. <i>Warning: Only for stacking, NOT for flying</i>
<u>LABI1-TBC</u>	Support to install a LABI1-C100i loudspeaker to truss
<u>LABI1-WBC</u>	LABI1-C100i wall mount bracket
<u>LABI1-PBC</u>	Pole adaptor to install LABI1-C100i loudspeakers in a 35mm standard pole
<u>LABI1-HBC</u>	High-density foam pieces to let LABI1-C100i rest on the floor horizontally. Allows 0°/ 30°/ 45° inclinations relative to the horizontal surface
<u>LABI1-ODCNX</u>	Outdoor kit to cover LABI1-C100i connections and make it ready for outdoor applications

5.3. ACCESSORIES

<u>LABI1-CFC</u>	Flight case for 2 LABI1-C100i + wiring + mounting accessories
<u>LABI1-SWK</u>	Wheel kit for LABI1-SB18p subwoofer
<u>LABI1-SPC</u>	Nylon protection cover for LABI1-SB18p subwoofer

6. START UP AND CONNECTION

LABI1-SB18p operates at 100-240VAC 50-60Hz, with PFC (Power Factor Correction). Ensure the main cable is not mixed with the audio signal cables, thereby preventing interferences and buzzing. The AC connector is a 16A Neutrik® Powercon TRUE1, and it features a mains link connector to supply another LABI1-SB18p unit. In the following link the assembly instructions and further information about the connector can be downloaded: <https://www.neutrik.com/en/product/nac3fx-w>

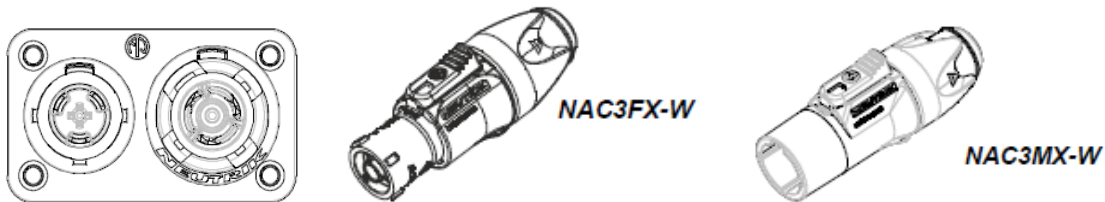

6.1. CONNECTIONS

- **LABI1-SB18p** features two balanced XLR audio inputs connectors, labelled Input1 and Input2. You can link a second LABI1-SB18p using Output1 and Output2, also available on XLR connectors. These outputs deliver a copy of the signal received at each input.

Depending on the preset, there are different input-output configurations allowing the system work in stereo or mono mode (further information is given in the next chapter). This stereo/mono setup does not affect at the subwoofer output, which always works in mono mode (In1+In2).

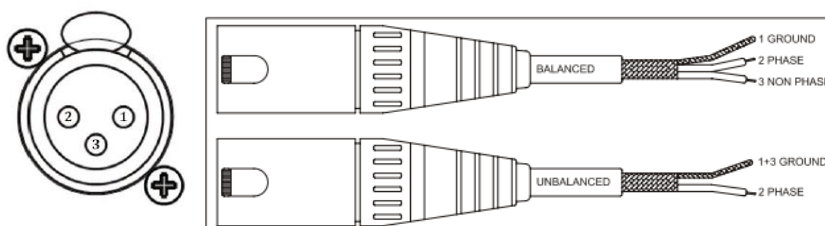

- To connect **LABI1-C100i** satellite loudspeakers, plug in the Speakon® cable from the SB18p output power connectors CABINET1 or CABINET2 to the C100i Speakon® input. Depending on the PRESET selected, one or both outputs can be used in mono or stereo mode, delivering 600W@4Ω. You can link two C100i column loudspeakers through the LINK output with Speakon® or Euroblock connector.
- **LABI1-SB18** passive subwoofer features one input and one stack output with Speakon® connectors.

6.2. CONFIGURATION PANEL

On the LAB11-SB18p back panel, an LCD screen provides information and configuration tools to allow the user to have a digital control of the loudspeaker system.

By default the screen is idle, until the OK button is pressed. If after 2 minutes changes are not made, the screen will automatically dim to save energy and avoid unnecessary light. The display indicates the name of the current preset, the temperature (T) and signal information (SP): “-∞” if there’s no signal, and “ON” if an input signal is connected. If a stereo preset is selected, there will be two information signals, one for each input.

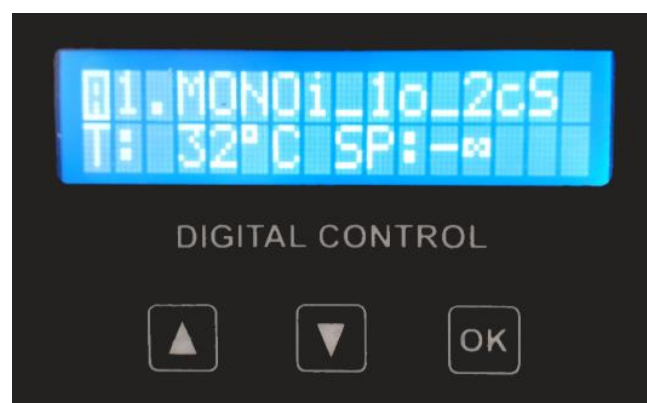

From the up and down arrow buttons it’s possible to select one of the 18 different presets. Hold down the OK button until the loading bar on the LCD screen is over, to complete the selection and be able to use the desired preset. In case of a power cut, DSP will keep its last preset when restarted.

A detailed explanation of the input-output configurations that offer all the different presets is explained in the next chapter.

7. INSTALLATION AND CONFIGURATION SYSTEMS

LABI ONE SERIES has been thought to allow the user to choose a huge variety of loudspeakers system configurations. Its accessories ensure the most installation versatility to install LABI ONE loudspeakers at any desired surface or structure.

7.1. LABI1-C100i: ACOUSTIC CENTRE

When the C100i column loudspeakers are installed, it's very important take into account that the acoustic centre of the column is located between the six speakers of the top. So the correct operational height will be the height of the “acoustic centre”.

LABI1-C100i is in its normal position when the ECLER logo is placed at the bottom of the column. When two columns have to be used to form one column, the upper column must be placed upside down to create a unique “acoustic centre” of the column.

In the images below, green shadow zone shows the “acoustic centre” of the LABI1-C100i loudspeaker columns:

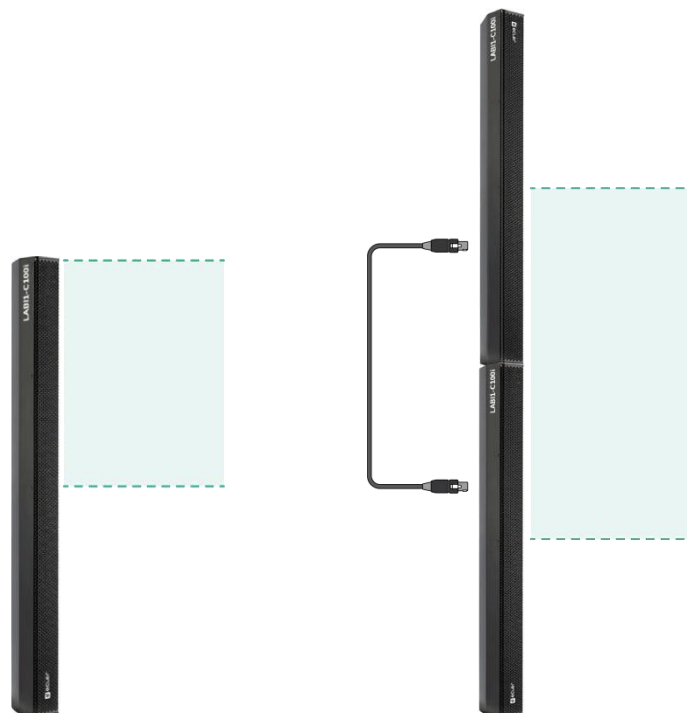

7.2. ACTIVE LOUDSPEAKERS SYSTEMS

7.2.1. PRESETS

There are 18 different presets available, selectable from the LCD screen control panel. These presets are grouped in 6 different loudspeaker configurations, and each group has 3 different DSP setups to allow the user choose depending on the purpose:

- Standard equalization (S): general equalization for standard music applications.
- Bass boost (B): +3dB to the subwoofer output for music applications with bass reinforcement.
- Voice equalization (V): the equalization emphasizes the mid-high frequencies for speech applications, enhancing intelligibility.

The following table summarizes the different presets available:

#	Name	Inputs	Outputs	Column speakers	DSP config.
1	MONOi_1o_2cS	In1 - Mono	Out 1 - Mono	2 LABI1-C100i	S
2	MONOi_1o_2cB				B
3	MONOi_1o_2cV				V
4	MONOi_1o_1cS	In1 - Mono	Out 1 - Mono	1 LABI1-C100i	S
5	MONOi_1o_1cB				B
6	MONOi_1o_1cV				V
7	STi_2So_2cS	In1 / In2 - Stereo	Out 1 & 2 - Stereo	2 LABI1-C100i + 2 LABI1-C100i	S
8	STi_2So_2cB				B
9	STi_2So_2cV				V
10	STi_2So_1cS	In1 / In2 - Stereo	Out 1 & 2 - Stereo	1 LABI1-C100i + 1 LABI1-C100i	S
11	STi_2So_1cB				B
12	STi_2So_1cV				V
13	STi_1Mo_2cS	In1 / In2 - Stereo	Out 1 - In1+In2	2 LABI1-C100i	S
14	STi_1Mo_2cB				B
15	STi_1Mo_2cV				V
16	STi_1Mo_1cS	In1 / In2 - Stereo	Out 1 - In1+In2	1 LABI1-C100i	S
17	STi_1Mo_1cB				B
18	STi_1Mo_1cV				V

Note: in the stereo presets the LABI1-SB18p subwoofer always combines In1 + In2.

7.2.2. LOUDSPEAKERS CONFIGURATION

- **Preset 1/2/3 & 13/14/15 (+LABI1-CAC & SAC):**

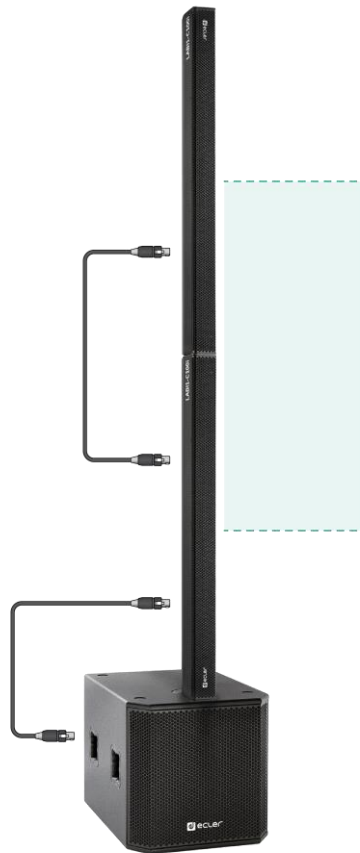

Note: take into account that the upper column must be installed upside down

- **Preset 4/5/6 & 16/17/18 (+LABI1-SAC):**



- Preset 7/8/9 (+2xLABI1-CAC):

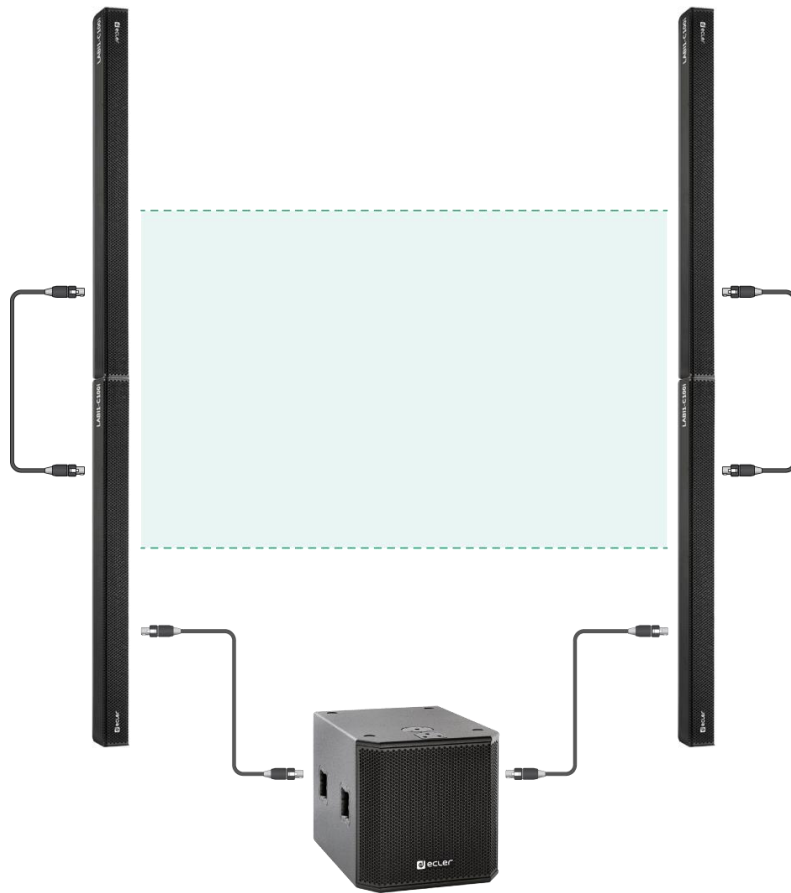

Note: take into account that the upper column must be installed upside down

- Preset 10/11/12:

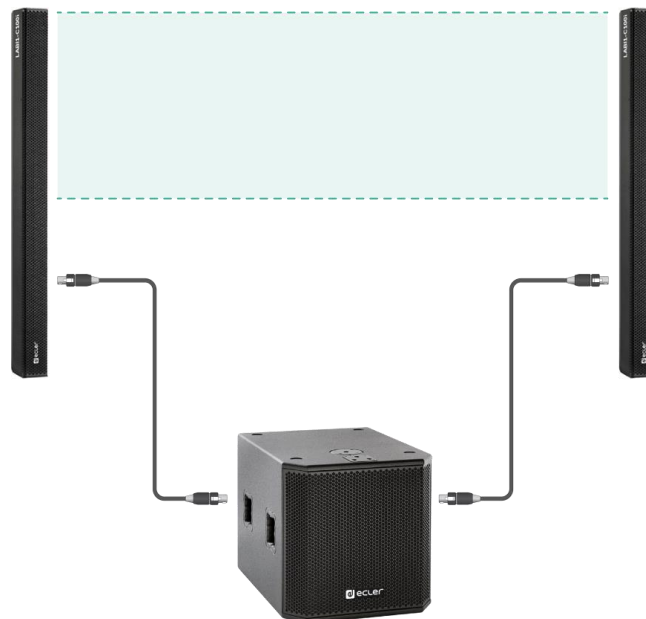

LABI1-C100i can be mounted in several different surfaces through its accessories: on pole (PBC), wall (WBC), truss (TBC) or on the floor (HBC).

Wheel kit LABI1-CFC, allow all these systems to be mobile, making the system easy to move and place wherever is needed.

7.3. PASSIVE LOUDSPEAKERS SYSTEMS

Besides active loudspeakers systems, LABI ONE series offers the possibility of being installed on passive loudspeakers systems, with external amplification.

LABI1-SB18 passive subwoofer has been designed to install in fixed loudspeaker systems. Together with C100i column loudspeakers and external power amplification, different configurations can be mounted with all the accessories available, depending on the user needs.

There is no rule governing the number of column speakers per subwoofer. It mainly depends on the subwoofer location and on the room acoustics. Thus in a highly reflective room, a subwoofer may even damage intelligibility, while several subwoofers could be necessary in a room with highly absorptive surfaces. Generally, it should be known that placing a subwoofer close to various surfaces will increase its efficiency. Consequently, the sound pressure level will be higher if you place the speaker on the ground in a corner rather than just beside a wall and even more than in the centre of a room.

To use LABI1-C100i in outdoor applications, LABI1-ODCNX outdoor kit is needed to ensure the protection of the connexions.

7.4. ACCESSORIES INSTALLATION

7.4.1. LABI1-SAC (Subwoofer – Adapter – Column)

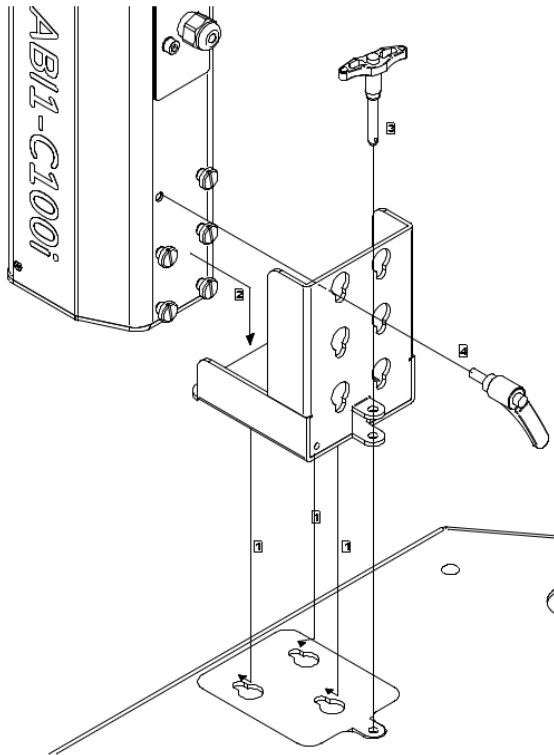

1. Attach LABI1-SAC into the subwoofer mounting holes
2. Secure LABI1-SAC with the included security key
3. Attach the column to the accessory
4. Secure the column with the included screw

7.4.2. LABI1-CAC (Column – Adapter – Column)

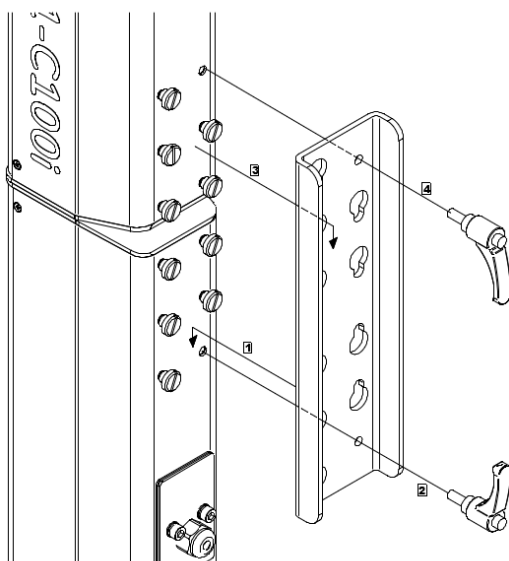

1. Attach LABI1-CAC to the down-column
2. Secure the down-column with the included screw
3. Attach the up-column to the accessory
4. Secure the up-column with the included screw

Warning: Only for stacking, NOT for flying

7.4.3. LABI1-TBC (Truss mount accessory)

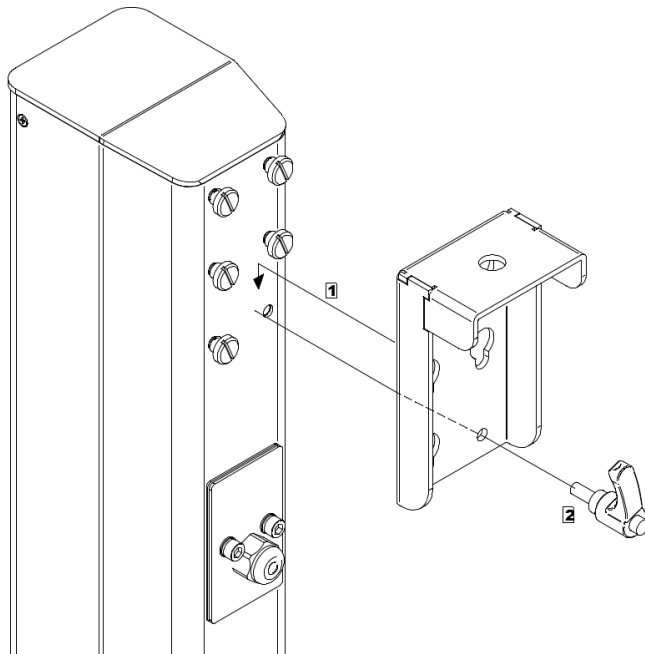

1. Attach the LABI1-TBC to the column
2. Secure the column with the included screw

Note: the accessory can be mounted in the top or in the middle of the column, depending on the needs required

7.4.4. LABI1-WBC (Wall mount accessory)

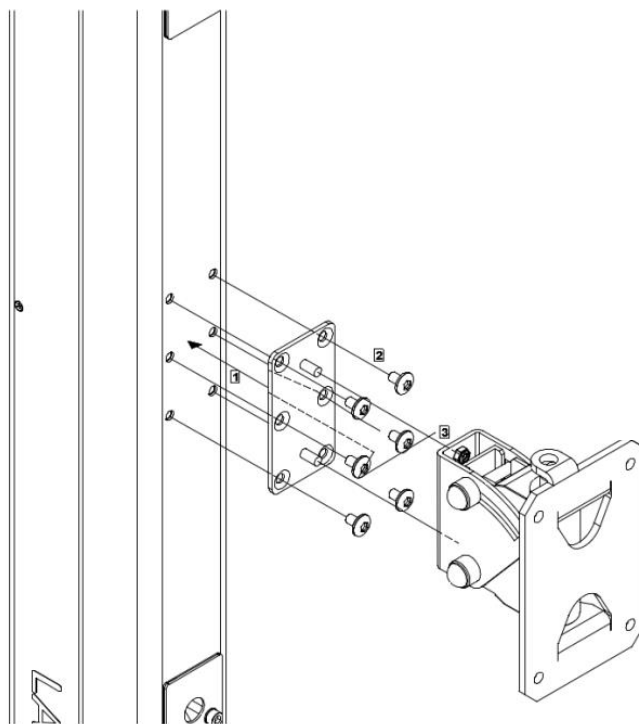

1. Unscrew the 6 bolts of the column
2. Screw LABI1-WBC base to the column
Screw the wall support to the desired wall, and then attach the column with the two remaining bolts of the WBC base

Note: the accessory can be mounted in the top or in the middle of the column, depending on the needs required

7.4.5. LABI1-PBC (Pole mount accessory)

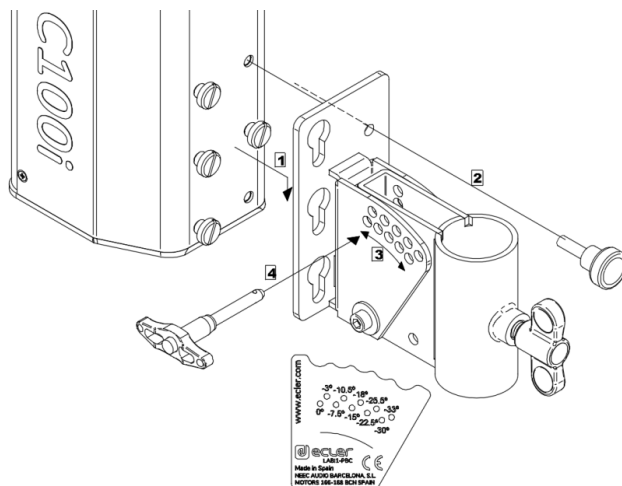

1. Attach the LABI1-PBC to the column
2. Secure the column with the included screw
3. Once mounted to the pole, move the accessory arm to tilt the column as desired
4. Secure the column tilt with the included screw

Note: the accessory can be mounted in the top or in the middle of the column, depending on the needs required

7.4.6. LABI1-ODCNX (Outdoor kit)

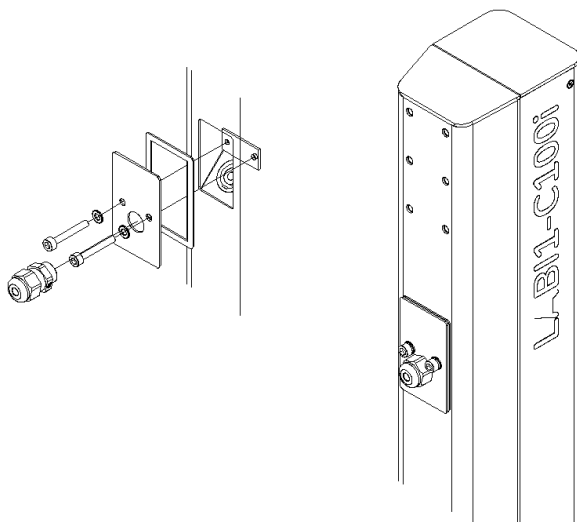

1. Connect the audio cable to the column, and pass it through the frame and the round hole of the LABI1-ODCNX
2. Screw the accessory bolts to the holes on the connections aperture, following the sequence shown in the scheme
3. Pass the cable through the cable gland
4. Insert the cable gland to the LABI1-ODCNX round hole, to ensure an hermetic enclosure

Note: when using this accessory, it can only be used the Euroblock connection

7.4.7. LABI1-HBC (Horizontal mount accessory)

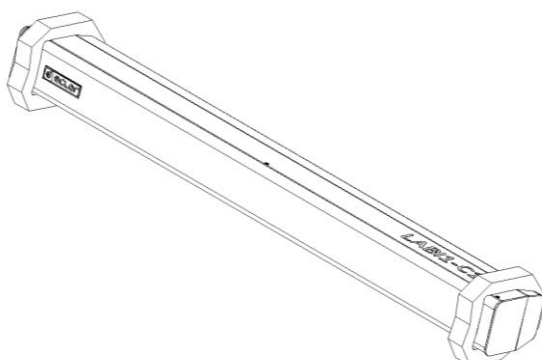

1. Place the LABI1-HBC foam pieces in both sides of the column, and tilt it as desired (0°, 30° or 45°)

8. REAR PANEL

8.1. LABI1-SB18p

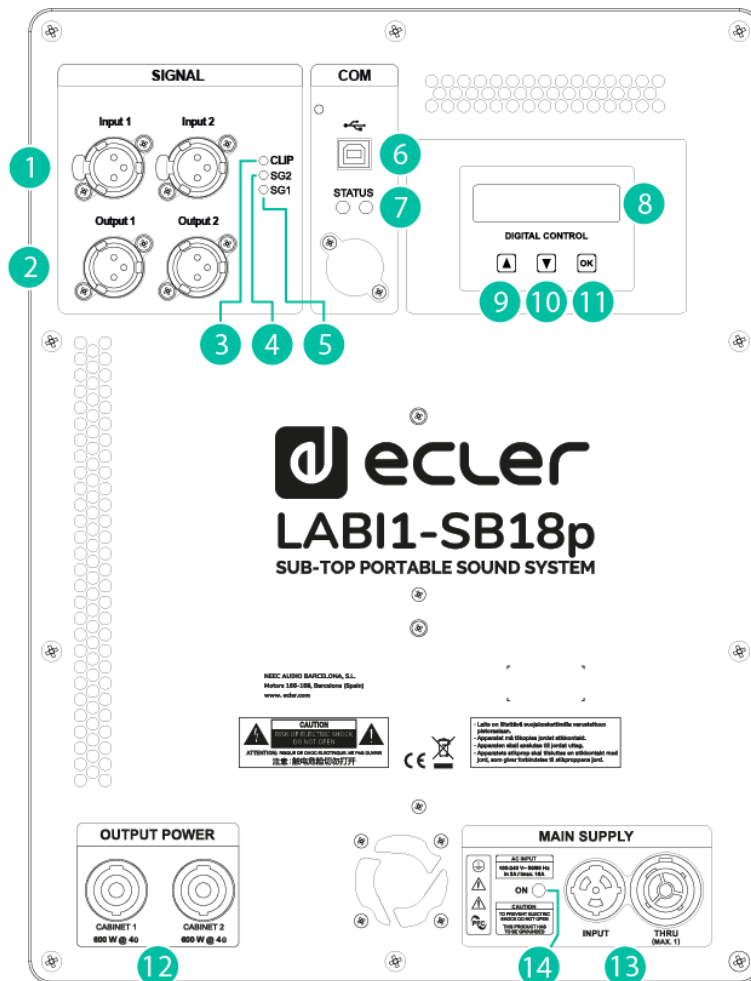

1. Balanced audio inputs – XLR connectors
2. Balanced audio outputs – XLR connectors
3. Clip indicator, CLIP
4. Signal present indicator, SG1
5. Signal present indicator, SG2
6. USB connector
7. STATUS indicator
8. LCD screen
9. Up-arrow button
10. Down-arrow button
11. OK button
12. Speaker outputs – Speakon® connectors
13. Main sockets
14. ON indicator

8.2. LABI1-SB18

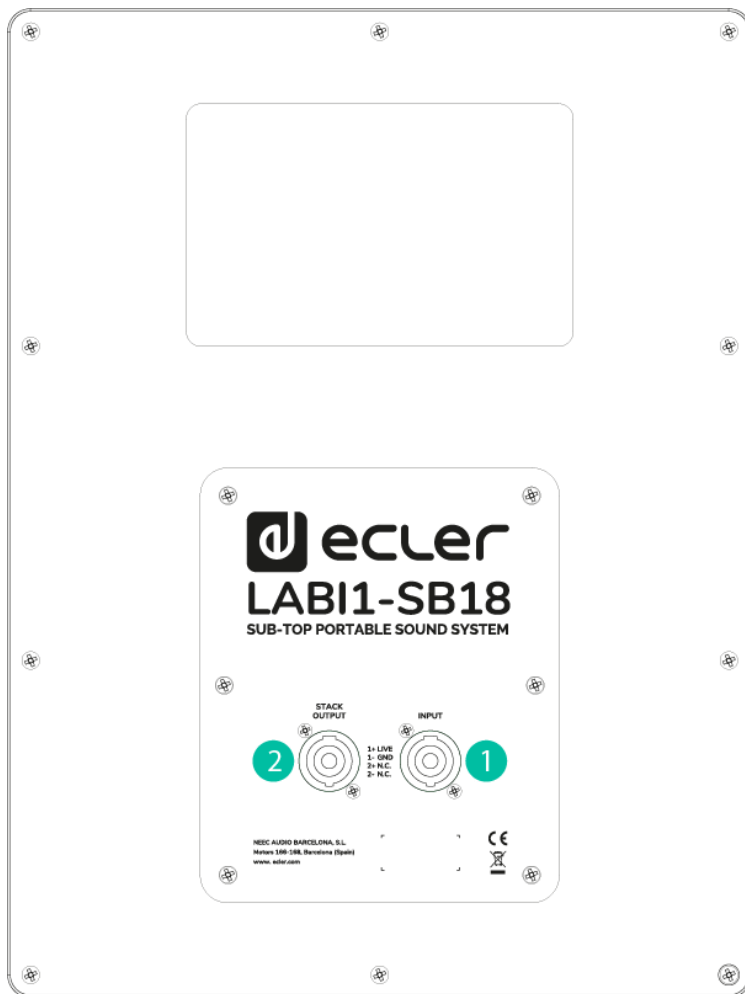

1. Speakon® input connector
2. Speakon® output connector, STACK

8.3. LABI1-C100i

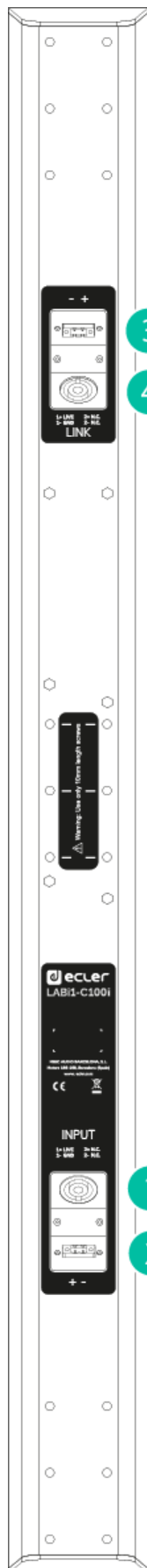

1. Euroblock input connector
2. Speakon® input connector
3. Euroblock output connector, LINK
4. Speakon® output connector, LINK

9. TECHNICAL SPECIFICATIONS

9.1. LABI1-SB18p

Drivers	18" subwoofer with 3" voice coil
Power	2400W Class D built-in amplification power with DC protection: Low freq: 1x1200W Speaker output (bal. load): 600W@4Ω + 600W@4Ω Speaker output (unbal. load): 800W@4Ω + 400W@8Ω
Power supply	Switching power supply and PFC system
Maximum SPL	132dB
Frequency response	42 Hz ~ 250 kHz (±3dB)
Frequency range	38 Hz ~ 250 kHz (-10dB)
Dispersion	Omnidirectional
Audio inputs	2 x XLR3 balanced
Audio outputs	2 x XLR3 balanced
Powered outputs	2 x Speakon®
Communication interfaces	LCD display and navigation keys USB-B: Only for configuration purposes
Processing	48 KHz / 56 bit double precision DSP 18 factory presets
IP rating	IP20
Material	15mm premium birch plywood with polyurea coating
Operating temperature	Min: 0°C ; 32°F Max: 35°C ; 95°F

9.2. LABI1-SB18

Drivers	18" subwoofer with 3" voice coil
AES Power	500W / 2000W peak
Impedance	8Ω
Sensitivity	98dB (1W/1m)
Maximum SPL	132dB
Frequency response	42 Hz ~ 250 kHz (±3dB)
Frequency range	38 Hz ~ 250 kHz (-10dB)
Dispersion	Omnidirectional
Audio inputs	Speakon®
Audio outputs	Speakon® (stack output)
IP rating	IP20
Material	15mm premium birch plywood with polyurea coating
Operating temperature	Min: 0°C ; 32°F Max: 35°C ; 95°F
Operating humidity	<85% HR
Storage temperature	Min: -10°C ; 14°F Max: 50°C ; 122°F
Storage humidity	<90% HR
Finished colour	Black (RAL 9005)
Dimensions (WxHxD)	513 x 513 x 704 mm / 20.2 x 20.2 x 27.7 in.
Weight	37.1 kg / 81.8 lb

9.3. LABI1-C100i

Drivers	12x3" transducers with 0.75" neodymium voice coil
AES Power	300W / 1200W peak
Impedance	8Ω
Sensitivity	96 dB (1W/1m)
Maximum SPL	121 dB-127dB peak
Frequency response	180 Hz ~ 20 kHz (±3dB)
Frequency range	150 Hz ~ 20 kHz (-10dB)
Dispersion	15°±5° x 100° (VxH)
Connection type	2 x Neutrik Speakon® NL4MP + 2 x Euroblock 2-pin + Link connection
IP rating	IP54 (with LABI1-ODCNX only)
Material	1.5mm stainless steel
Operating temperature	Min: 0°C ; 32°F Max: 35°C ; 95°F
Operating humidity	<85% HR
Storage temperature	Min: -10°C ; 14°F Max: 50°C ; 122°F
Storage humidity	<90% HR
Finished colour	Black (RAL 9005)
Dimensions (WxHxD)	89 x 1000 x 117 mm / 3.5" x 39.4" x 4.6"
Weight	7.8 kg / 17.2 lb

All product characteristics are subject to variation due to production tolerances. **NEEC AUDIO BARCELONA S.L.** reserves the right to make changes or improvements in the design or manufacturing that may affect these product specifications.

For technical queries contact your supplier, distributor or complete the contact form on our website, in [Support / Technical requests](#).

Motors, 166-168 08038 Barcelona - Spain - (+34) 932238403 | information@ecler.com | www.ecler.com