

MIMO4040CDN

DIGITALE MATRIZEN

Digitale Matrix für Konferenzen mit akustischer Echokompensation und DANTE™/AES67-Schnittstelle



BEDIENUNGSANLEITUNG

INHALTSVERZEICHNIS

HARDWARE	4-21
1 WICHTIGE VORBEMERKUNG	4
2 WICHTIGE SICHERHEITSHINWEISE	4
3 WICHTIGER HINWEIS.....	6
4 EINFÜHRUNG	6
4.1 Die wichtigsten Merkmale.....	7
5 EINBAU.....	8
5.1 Standort, Einbau und Lüftung	8
5.2 Anschluss ans Stromnetz und Einschalten des Geräts.....	9
5.3 Analoge Audioeingänge	9
5.4 Analoge Audioausgänge	10
5.5 Digitale DANTE™/AES67-Audioeingänge und DANTE™/AES67- Audioausgänge über IP.....	10
5.6 Ethernet-Port für Programmierung und Steuerung	12
5.6.1 Werkseitig voreingestellte Netzwerkparameter	12
5.7 RS-232-Port zur Fernbedienung.....	13
5.8 GPI-Ports für Fernsteuerung	13
5.9 GPO-Ports für Fernsteuerung.....	15
6 ZU BEACHTENDE PUNKTE.....	15
6.1 Masseschleifen.....	15
6.2 Hintergrundrauschen	15
7 LIEFERUMFANG	16
8 LISTE DER FUNKTIONEN	16
9 FUNKTIONSDIAGRAMM.....	17
10 BLOCKDIAGRAMM	18
11 TECHNISCHE DATEN	19
SOFTWARE	22-80
12 TP-NET PROTOCOL INTRODUCTION.....	23

13	NXA DIGITAL AUDIO MANAGER SERIES.....	27
14	NZA MULTICHANNEL AMPLIFIER SERIES.....	31
15	NPA STEREO AMPLIFIER SERIES.....	32
16	MIMO88 / MIMO88 CONFERENCE / MIMO88SG / MIMO1212SG (SINGLE) DIGITAL MATRIX.....	35
17	MIMO88SG CONFERENCE DIGITAL MATRIX.....	40
18	MIMO 7272DN / MIMO4040CDN DIGITAL MATRIX.....	41
	18.1 <i>MIMO4040CDN: AEC MANAGEMENT.....</i>	46
19	DUO-NET PLAYER AUDIO PLAYER & STREAMING RECEIVER.....	48
20	ERROR CODES FOR ECLERNET DEVICES	54
	20.1 <i>COMMON ERROR CODES (to all EclerNet - TP-NET compatible devices).....</i>	54
	20.2 <i>NXA SERIES SPECIFIC ERROR CODES.....</i>	55
	20.3 <i>NZA SERIES SPECIFIC ERROR CODES.....</i>	56
	20.4 <i>NPA, MIMO7272DN, MIMO4040CDN, MIMO88 & MIMO88 CONFERENCE SERIES SPECIFIC ERROR CODES.....</i>	57
	20.5 <i>MIMO88SG, MIMO1212SG, MIMO88SG CONFERENCE & MIMO1212SG CONFERENCE SERIES SPECIFIC ERROR CODES.....</i>	58
	20.6 <i>DUO-NET PLAYER SPECIFIC ERROR CODES.....</i>	59
21	eMIMO1616 DIGITAL MATRIX.....	60
22	eMIMO1616 ERROR CODES.....	67
23	HUB SERIES DIGITAL ZONER.....	68
24	HUB SERIES ERROR CODES	75

1 WICHTIGE VORBEMERKUNG



WARNING: SHOCK HAZARD - DO NOT OPEN

AVIS: RISQUE DE CHOC ÉLECTRIQUE - NE PAS OUVRIR



Das Blitzsymbol mit dem Pfeil innerhalb eines gleichseitigen Dreiecks soll den Benutzer vor nicht isolierter „gefährlicher Spannung“ innerhalb des Produktgehäuses warnen, die hoch genug ist, um einem Menschen einen elektrischen Schlag zu versetzen.



Das Ausrufezeichen innerhalb eines gleichseitigen Dreiecks soll den Benutzer darauf hinweisen, dass mit dem Gerät wichtige Gebrauchs- und Wartungs-(Service-)anleitungen in dieser Gebrauchsanweisung geliefert wurden.

WARNUNG (falls zutreffend): Bei den mit dem Symbol "  " gekennzeichneten Anschlüsse, kann Stromschlaggefahr bestehen. Die externe Verdrahtung, die an die Klemmen angeschlossen wird, muss von qualifiziertem Personal oder mit vorkonfektionierten Kabeln installiert werden.

WARNUNG: Wegen Feuer- und Stromschlaggefahr, das Gerät niemals Regen oder Feuchtigkeit aussetzen.

WARNUNG: Ein Gerät der Klasse I muss an eine geerdete Steckdose angeschlossen werden.

2 WICHTIGE SICHERHEITSHINWEISE

1. Lesen Sie diese Anweisung durch.
2. Bewahren Sie diese Anweisung gut auf.
3. Beachten Sie alle Warnhinweise.
4. Befolgen Sie alle Anweisungen.
5. Benutzen Sie das Gerät nicht in der Nähe von Wasser.
6. Reinigen Sie es nur mit einem trockenem Tuch.
7. Blockieren Sie keine Lüftungsöffnungen. Das Gerät sollte gemäß den Herstellerangaben installiert werden.
8. Stellen Sie das Gerät nicht in der Nähe von Wärmequellen wie Heizkörpern, Radiatoren, Öfen oder anderen Geräten (einschließlich Verstärkern), die Wärme erzeugen, auf.

9. Annullieren Sie nicht den Sicherheitsmechanismus des gepolten oder geerdeten Steckers. Ein gepolter Stecker hat zwei Stifte, wobei einer davon breiter ist. Ein geerdeter Stecker hat zwei Stifte und einen dritten Erdungsstift. Der breite bzw. dritte Stift dient Ihrer Sicherheit. Wenn der mitgelieferte Stecker nicht in Ihre Steckdose passt, wenden Sie sich an einen Elektriker, um die veraltete Steckdose auszutauschen.
10. Sorgen Sie dafür, dass niemand auf das Netzkabel tritt und dass es nicht gequetscht wird, insbesondere an Steckern, Steckerbuchsen und an der Stelle, an dem es aus dem Gerät kommt.
11. Verwenden Sie nur die vom Hersteller angegebenen Zusatzgeräte/Zubehörteile.
12. Ziehen Sie bei einem Gewitter oder wenn das Gerät längere Zeit nicht verwendet wird den Netzstecker.
13. Alle Servicearbeiten sind von qualifiziertem Fachpersonal durchzuführen. Servicearbeiten sind notwendig, wenn das Gerät in jeglicher Art beschädigt wurde, z. B. wenn das Netzkabel oder der Netzstecker beschädigt ist, wenn Flüssigkeiten über das Gerät geschüttet wurde oder Gegenstände hineingefallen sind, es Regen oder Feuchtigkeit ausgesetzt wurde, nicht normal funktioniert oder heruntergefallen ist.
14. Vom Stromnetz trennen: Durch Ausschalten des POWER-Schalters (13) werden alle Funktionen gestoppt und die Anzeigen des Verstärkers erlöschen. Das Gerät wird aber nur durch Ziehen des Netzsteckers (11) vollständig vom Stromnetz getrennt. Deshalb müssen Netzstecker und Steckdose leicht zugänglich sein.
15. Das Gerät wird über ein Netzkabel an eine geerdete Steckdose angeschlossen.
16. Die Markierungsinformation befindet sich am Boden des Geräts.
17. Das Gerät darf keinem Tropf- oder Spritzwasser ausgesetzt werden und es dürfen keine mit Flüssigkeiten gefüllten Gegenstände, wie Vasen, auf das Gerät gestellt werden.
18. Die externe Verkabelung muss von einem Fachmann angeschlossen werden.



WARNUNG: Dieses Produkt darf unter keinen Umständen als unsortierter Siedlungsabfall entsorgt werden. Gehe zum nächsten Abfallverwertungszentrum für elektrische und elektronische Geräte.

VORSICHT. Batterie in diesem Produkt enthalten. Beachten Sie die folgenden Sicherheitshinweise:

1. Durch Ersetzen des falschen Batterietyps wird der Sicherheitsschutz ungültig
2. Eine Explosion kann durch Einlegen der Batterie in den Feuer- oder Heizofen oder durch Entsorgen der Batterie durch mechanisches Extrudieren oder Schneiden verursacht werden
3. Wenn Sie die Batterie in eine Umgebung mit extrem hohen Temperaturen und brennbarer Flüssigkeit oder brennbarem Gas bringen, kann die Batterie explodieren oder auslaufen.
4. Der extrem niedrige Luftdruck von brennbarer Flüssigkeit und Gas auf der Batterie kann dazu führen, dass die Batterie explodiert oder ausläuft.

NEEC AUDIO BARCELONA, S.L. übernimmt keine Haftung für Schäden, die Personen, Tieren oder Gegenständen durch die Nichtbeachtung der obigen Warnungen entstehen können.

3 WICHTIGER HINWEIS

Wir bedanken uns für das Vertrauen, das Sie mit der Wahl unserer **digitale Audiomatrix für Konferenzenanwendungen, einschließlich AEC- und Dante™ -Schnittstelle** in uns gesetzt haben.

Um eine optimale Betriebsfähigkeit und Leistung zu erzielen, ist es **SEHR WICHTIG**, dass Sie vor dem Anschluss des Geräts die in dieser Anleitung enthaltenen Hinweise aufmerksam durchlesen und berücksichtigen.

Für ein optimales Funktionieren des Geräts empfehlen wir Ihnen, die Instandhaltung ausschliesslich von unseren autorisierten technischen Servicepartnern durchführen zu lassen.

Auf den Ecler **MIMO4040CDN** gewähren wir eine Garantie von **3** Jahren.

4 EINFÜHRUNG

Die MIMO4040CDN ist eine digitale 40x40 Einbau-Audiomatrix (40 Eingänge und 40 Ausgänge), vollkommen programmierbar über die Anwendung EclerNet Manager^(*).

^(*)Nähere Informationen hierzu finden Sie im Handbuch der Anwendung EclerNet Manager. Die Anwendung EclerNet Manager steht Ihnen unter www.ecler.com zum Herunterladen zur Verfügung.

Sie hat 8 analoge Audioeingänge und 8 analoge Audioausgänge, 32 digitale DANTE™/AES67-Audioeingänge und 32 digitale DANTE™/AES67-Audioausgänge, was sie zu einer 40x40-Matrix mit nativer Signalverarbeitung und echtem Routing von jedem Eingang zu jedem Ausgang macht. Enthält auch bis zu 8 Eingangskanäle mit Echokompensation (AEC) für Audio- / Videokonferenzenanwendungen ^(*)

^(*) Die Echokompensationsfunktion wird durch die Überprüfung der Software-Lizenz (SF) für eine bestimmte Hardware-Einheit (HW) aktiviert. Weitere Informationen erhalten Sie von Ihrem offiziellen Ecler-Händler.

MIMO4040CDN ist nur mit CONFERENCE-Firmware und nicht mit Firmware für Standardanwendungen verfügbar. Informationen zu diesen Anwendungstypen finden Sie in den Funktionen des MIMO7272DN-Modells.

4.1 Die wichtigsten Merkmale

- 8 analoge Audioeingänge MICRO/LINE, symmetrisch, (unabhängige 42VDC Phantomspeisung an jedem Eingangskanal). Euroblock-Anschlüsse
- 8 symmetrische analoge Audioausgänge. Euroblock-Anschlüsse
- 2 symmetrische MONITOR-Ausgänge. Euroblock-Buchse an der Rückseite + Stereo-Jack-Buchse vorne
- 32 digitale DANTE™/AES67-Audio-Eingangskanäle
- 32 digitale DANTE™/AES67-Audio-Ausgangskanäle
- Erlaubt die Nutzung von Netzwerk-Redundanz zum Audiotransport über IP (2 DANTE™/AES67-Ports: primär & sekundär)
- 8 GPI-Steuerungseingänge (General Purpose Input)
- 8 GPI-Steuerungsausgänge (General Purpose Output)
- Ethernet-Steuerungsport, RJ45-Anschluss (kompatibel mit EclerNet Manager, UCPs und TP-NET-Protokoll)
- RS-232-Steuerungsport, DB9-Anschluss (zur Integration von Drittsystemen über TP-NET-Protokoll)
- Fernsteuerung und –programmierung über Ethernet mithilfe der Anwendung EclerNet Manager (Punkt-zu-Punkt über Direktverbindung mit Kabel der Kategorie CAT5/CAT6, oder aber ausgehend von einem Ethernet-Netzanschluss)
- Fernbedienung über benutzerdefinierte UCPs (User Control Panels)
- Fernbedienungs-Anwendung für iOS und Android verfügbar (Ecler UCP V2)
- Fernsteuerung mittels externer Geräte von Drittanbietern (Crestron, AMX, Extron, Medialon usw., von den jeweiligen Herstellern eingetragene Marken). TP-NET-Protokoll über Ethernet- oder RS-232-Schnittstelle
- Fernbedienung über digitale Bedientafeln, die ans gleiche Ethernet-Netzwerk angeschlossen sind (Geräte der Baureihen WPNET)
- Eingebetteter UCP-Server: EclerNet-Projekte werden im Prozessor der Matrix ausgeführt, indem diese als Server von UCP-Bedienfeldern sowie als Steuerung der im Projekt enthaltenen Hardwaregeräte arbeitet.
- Steuerung von Konfigurationsspeichern (Presets)
- Programmierte Ereignisse auf Kalenderbasis
- Umfassende und konfigurierbare Möglichkeiten der Signalverarbeitung (DSP).
Beispiele:
 - Router-Mixer-Matrix, von jedem Eingang zu jedem Ausgang (analog und/oder digital DANTE™/AES67) mit PegelEinstellung für jeden Kreuzungspunkt (unabhängige Mischungen von unterschiedlichen Eingängen für jeden Ausgang)
 - Kanäle können in Mono- oder Stereobetrieb arbeiten
 - Pegel, Stummschaltung, VU-Meter und Phaseneinstellung an Ein- und Ausgängen

- Interner Signalgenerator (Sinussignal, rosa Rauschen, weisses Rauschen, Polaritätstest)
- parametrischer EQ an den Ein- und Ausgängen
- Verzögerung an den Ein- und Ausgängen
- Noise-Gate / Kompressor an den Eingangskanälen
- Kompressor / Limiter an den Ausgängen
- Prioritäten (Ducking) unter den Eingangskanälen
- Virtuelle und reale Durchsagekonsolen (Paging)
- Auto-Mixer
- Rückkopplungsschleifen-Canceller (Larsen-Effekt), o Rückkopplungskiller
- Acoustic Echo Cancellation (AEC), aktiviert durch SW-Lizenz

Die Programmierung der MIMO4040CDN erfolgt über die Anwendung EclerNet Manager (*). Nähere Information hierzu finden Sie im EclerNet Manager Anwendungshandbuch auf unserer Website www.ecler.com.

(*) Die Anwendung EclerNet Manager steht Ihnen unter www.ecler.com zum Herunterladen zur Verfügung.

5 EINBAU

5.1 Standort, Einbau und Lüftung

Die MIMO4040CDN wurde speziell für die Unterbringung in 19“-Racks konstruiert, wo sie eine HE ausfüllt.

Da die MIMO4040CDN Hitze erzeugt, ist es sehr wichtig, dass sie nicht vollkommen luftdicht aufgestellt und keinen extremen Temperaturen ausgesetzt wird. Es muss für freien Abzug der Luft aus den Lüftungsöffnungen des Gehäuses gesorgt werden, das heisst, unterhalb und oberhalb eines installierten Geräts muss jeweils eine HE des Racks freigelassen werden.

Hat die Anlage mehrere Verstärker im gleichen Rack oder ist sie in einem mit Türen verschlossenen Schrank eingebaut, so wird dringend empfohlen, eine nach oben abgeführte Zwangsbelüftung einzubauen, d.h., Ventilatoren unten und oben. Dieser nach oben fließende Lüftungsstrom begünstigt die Abführung der im Inneren des Racks oder Schrankes erzeugten Wärme.

5.2 Anschluss ans Stromnetz und Einschalten des Geräts

Die MIMO4040CDN arbeitet mit Wechselspannung von 90 bis 264V und 47 bis 63Hz. Das Gerät besitzt ein überdimensioniertes Netzteil, das in der Lage ist, sich ohne zusätzliche Einstellungen weltweit an jedwede Netzspannung anzupassen.

An der Rückseite befindet sich beim Versorgungsanschluss nach IEC-Norm ein Schalter zum Ein- und Ausschalten des Geräts. An der Vorderseite befindet sich eine LED-Anzeige, die leuchtet, wenn das Gerät in Betrieb ist.

Um unerwünschte Brummgeräusche zu vermeiden, muss verhindert werden, dass sich das Netzkabel mit den abgeschirmten Kabeln, die das Audiosignal transportieren, vermischt oder parallel dazu verläuft.

5.3 Analoge Audioeingänge

Die MIMO4040CDN verfügt an ihrer Rückseite über 8 analoge Signaleingänge (IN 1 bis 8), diese sind symmetrisch und lassen Line- und Microsignale zu. Die Auswahl der Signalart des Eingangssignals und seine Steuerung erfolgt über die [Anwendung EclerNet Manager](#). Nähere Information hierzu finden Sie im EclerNet Manager Anwendungshandbuch auf unserer Website www.ecler.com.

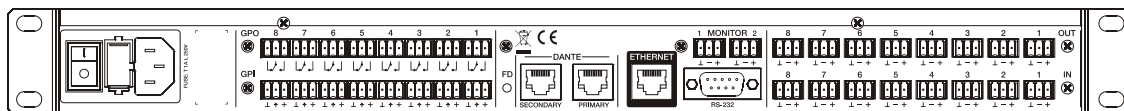

Die Anschlüsse für den Signaleingang sind vom Typ Euroblock. Die Anschlüsse sind wie folgt zugewiesen:

Hot oder direktes Signal	>	Pin +
Cold oder phasenverkehrtes Signal	>	Pin -
Masse	>	Pin ⊥

Für asymmetrische Anschlüsse muss der -Pin mit Masse kurzgeschlossen werden.

5.4 Analoge Audioausgänge

Die MIMO4040CDN verfügt an ihrer Rückseite über 8 analoge Signalausgänge (OUT 1 bis 8) sowie über 2 zusätzliche Monitorausgänge „MONITOR“; diese sind symmetrisch und mit Linepegel.

Die Anschlüsse für den Signalausgang sind vom Typ Euroblock. Die Anschlüsse sind wie folgt zugewiesen:

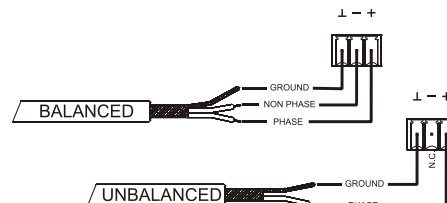

Hot oder direktes Signal	>	Pin +
Cold oder phasenverkehrtes Signal	>	Pin -
Masse	>	Pin ⊥

Für asymmetrische Anschlüsse den Pinout - nicht anschliessen.

5.5 Digitale DANTE™/AES67-Audioeingänge und DANTE™/AES67-Audioausgänge über IP

(Ports für Primär- und Sekundär-Netzwerke)

Die MIMO4040CDN ermöglicht den Empfang von 32 digitalen DANTE™/AES67 Audiokanälen und die Sendung von 32 digitalen DANTE™/AES67 Audiokanälen über ein Ethernet-Netzwerk, das mit digitalem Audiotransport über IP mittels Dante™-Protokoll kompatibel ist.

Das Routing der digitalen Dante™-Audiosignale über das Ethernet-Netzwerk sowie die Netzwerkkonfiguration der Dante™-Ports (IP-Adressen, Masken usw.) der MIMO4040CDN werden über die Software-Anwendung Dante Controller gesteuert. Nähere Informationen hierzu finden Sie in den Unterlagen des Entwicklers: <https://www.audinate.com/products/software/dante-controller?lang=de>

Die MIMO4040CDN hat an ihrer Rückseite zwei Anschlüsse mit RJ45-Schnittstelle zum Senden und Empfangen digitaler DANTE™/AES67-Audioinhalte. Diese sind als primär (PRIMARY) und sekundär (SECONDARY) beschriftet. Mit diesen beiden Ports kann die MIMO4040CDN in zwei möglichen Betriebsarten arbeiten:

- **Redundanter Betrieb:** Es existieren gleichzeitig zwei Netzwerkverbindungen (jede mit ihrer eigenen IP-Adresse, die sich von der der jeweils anderen Verbindung

unterscheidet), d.h., die Ethernet-Pakete mit DANTE™/AES67-Informationen werden über beide Verbindungen übermittelt. Die beiden Ports (primär und sekundär) müssen an unterschiedliche lokale Ethernet-Netzwerke angeschlossen sein, diese können real oder virtuell (VLAN) sein und müssen richtig konfiguriert und gegeneinander isoliert werden. Die digitalen DANTE™/AES67-Audioinhalte werden somit über zwei unterschiedliche und voneinander unabhängige Wege gesendet und empfangen, ohne dass zwischen dem primären und dem sekundären Port eine Verbindung besteht. Sollte einer dieser beiden Wege ausfallen, so schaltet die MIMO4040CDN automatisch auf den anderen Weg um und stellt so die Audioübertragung praktisch sofort wieder her. Es liegt auf der Hand, dass zur Erreichung einer totalen Redundanz alle zu einem System dieser Art gehörenden DANTE™/AES67-Geräte mit primärem und sekundärem DANTE™/AES67-Port ausgestattet sein müssen, und dass diese jeweils an die gleichen beiden unabhängigen Netzwerke angeschlossen sein müssen wie die MIMO4040CDN.

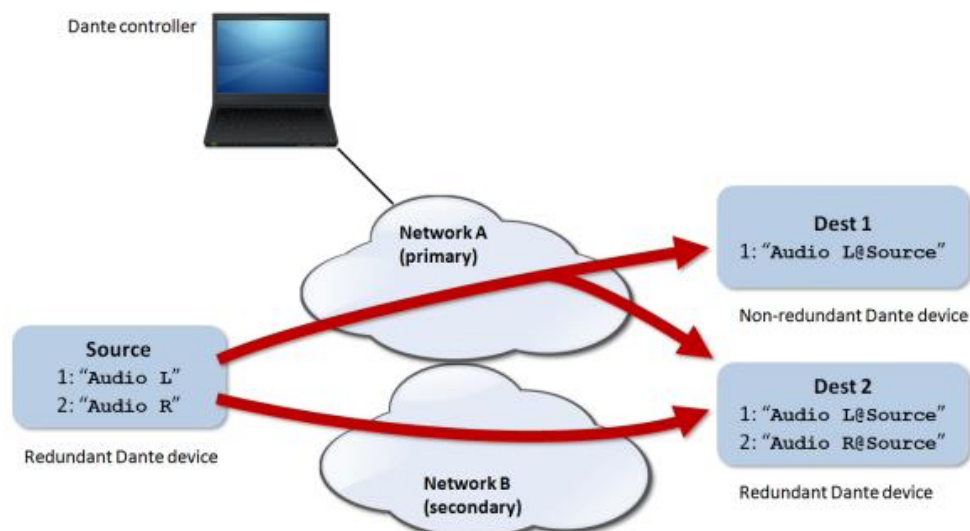

Achtung: Sollten in dieser Betriebsart der primäre und der sekundäre Port (versehentlich) an ein und dasselbe Ethernet-Netzwerk angeschlossen werden, so hätte die Anwendung Dante Controller keinen Zugriff mehr auf die Steuerung der Netzwerk-Konfiguration und des DANTE™/AES67-Routings der Ports der MIMO4040CDN. Der Zugriff auf die Steuerung wird wiedererlangt, sobald einer der beiden Ports von diesem Netzwerk getrennt wird.

Achtung: Die DANTE™/AES67-Redundanz erfordert, dass die primären und sekundären Ports aller angeschlossenen DANTE™/AES67-Geräte die gleiche Netzanschluss-Geschwindigkeit haben. Wird beispielsweise der Primärport mit einer Verbindung von 1 Gbps angeschlossen, so muss der Sekundärport ebenfalls eine Verbindung von 1 Gbps benutzen.

- **Schaltmodus (Switched):** In dieser Betriebsart steht eigentlich nur ein Netzwerkanschluss zur Verfügung (und somit nur eine IP-Adresse), und Primär- und Sekundärport verhalten sich wie zwei Ports, die zu einem in die MIMO4040CDN integrierten Netzwerk-Switch gehören, und an die Geräte, die zum DANTE™/AES67-Netzwerk des Systems gehören, oder aber Ethernet-Switches, die Teil der Infrastruktur dieses Netzwerkes sind, direkt angeschlossen werden können.

Achtung: in dieser Betriebsart dürfen niemals beide Ports, also der primäre und der sekundäre, gleichzeitig an ein Netzwerk-Switch angeschlossen werden, denn dadurch würde eine Netzwerk-Schleife entstehen, die zu Konflikten im Netz führen und den digitalen DANTE™/AES67-Audioverkehr unterbrechen würde.

5.6 Ethernet-Port für Programmierung und Steuerung

Der mit ETHERNET beschriftete RJ45-Anschluss erlaubt den Anschluss des Geräts an ein lokales Ethernet-Netzwerk (LAN) und ist für folgende Zwecke geeignet:

- Steuerung von der Anwendung EclerNet Manager aus über direkten Anschluss (Kabel der Kategorie CAT5 oder höher) eines Rechners an eine MIMO4040CDN oder aber durch Nutzung eines Ethernet-Netzwerkes als Verbindung zwischen beiden Geräten. Nähere Information hierzu finden Sie im EclerNet Manager Anwendungshandbuch auf unserer Website www.ecler.com
- Anschluss an Steuergeräte von Drittanbietern (Crestron, AMX, Vity, Medialon, usw., vom jeweiligen Hersteller eingetragene Marken). Angewandtes Protokoll: Ecler TP-NET Nähere Informationen finden [Sie im Handbuch des TP-NET-Protokolls](#).
- UCP: Fernsteuerung von EclerNet-Projekten über benutzerdefinierbare grafische Bedienfelder. Die MIMO4040CDN kann als Server dieser in EclerNet-Projekte integrierten Bedienfelder agieren, oder auch per Fernbedienung über Client-Geräte von UCP-Bedienfeldern (WPNETTOUCH, mobile Android®- oder iOS®-Geräte, Windows®-Geräte usw.) gesteuert werden.

5.6.1 Werkseitig voreingestellte Netzwerkparameter

Die werksseitigen Standard-Netzwerkeinstellungen für kompatible Geräte mit EclerNet Manager sind folgende:

- IP: 192.168.0.100
- Mask: 255.255.255.0
- Gate: 192.168.0.1
- UDP Port: 2210

5.7 RS-232-Port zur Fernbedienung

Der an der Geräterückseite integrierte RS-232-Port mit integriertem DB9-Anschluss ermöglicht die Kommunikation eines externen Geräts mit einer MIMO4040CDN über seriellen Anschluss. Dieser Anschluss verwendet die Syntax des TP-NET-Protokolls, damit das externe Gerät den Wert einiger der Parameter der MIMO4040CDN übernehmen (über "GET"-Befehle) und/oder solche Werte ändern kann (über "SET"-Befehle). Nähere Informationen finden [Sie im Handbuch des TP-NET-Protokolls](#).

Der serielle Anschluss muss folgende Merkmale erfüllen:

- Baud rate: 115200 (fixed, no auto negotiation)
- Data bits: 8
- Parity: None
- Stop bits: 1
- Flow control: None

5.8 GPI-Ports für Fernsteuerung

Die MIMO4040CDN verfügt an ihrer Rückseite über 8 GPI-Eingänge, die über Gleichstrom von 0 bis 10 VDC angesteuert werden. Jeder dieser Eingänge kann an ein reales externes Gerät angeschlossen (Potentiometer, Kontaktschluss, variable Gleichspannung 0-10V usw.) und einer Funktion der MIMO4040CDN zugewiesen werden, zum Beispiel:

- Einstellung der Lautstärke eines Ein- oder Ausgangskanals oder eines Kreuzungspunkts der Audiomatrix über ein reales Potentiometer oder über ein Fernbedienungs-Gerät aus der Baureihe **WPa** von Ecler
- Aktivierung / Deaktivierung eines MUTE oder SOLO mittels Taster oder Kontaktschluss
- Aufruf eines Presets mittels Taster oder Kontaktschluss

Die GPI-Anschlüsse sind vom Typ Euroblock. Die Anschlüsse sind wie folgt zugewiesen:

Positiv, + 12 VDC	>	Pin +
Variable Spannung, 0-12 VDC	>	Pin ↑
Masse	>	Pin ⊥

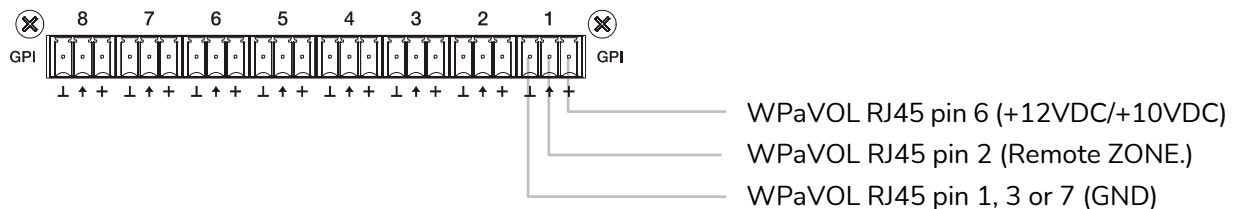

Jumpers position: ALOG / LIN → **LIN position**
 +12 / +10 → **+12 position**

Anschluss WPaVOL an seriellen MIMO-GPI-Ports

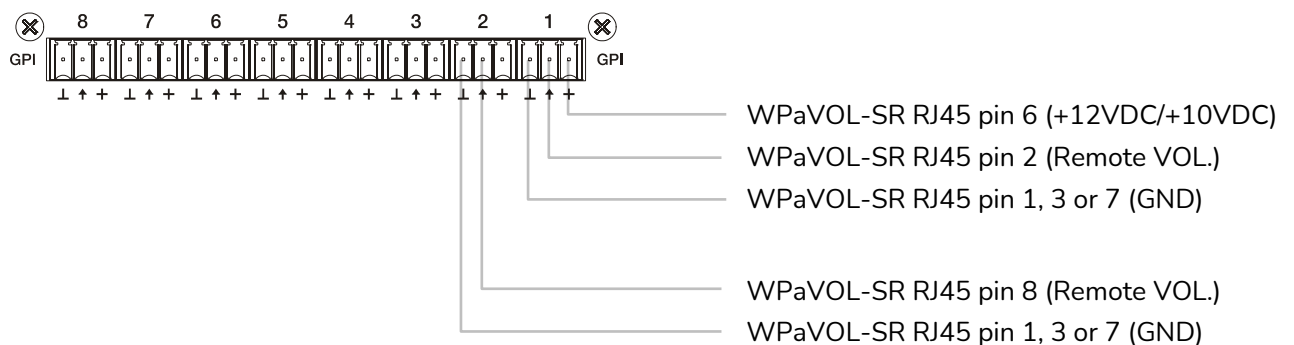

Jumpers position: ALOG / LIN → **LIN position**
 +12 / +10 → **+12 position**

Anschluss WPaVOL-SR an seriellen MIMO-GPI-Ports

Die Anschlusskabel können bis zu ca. 500 Meter lang sein, wenn ein Querschnitt von mindestens 0,5 mm² verwendet wird.

Erkundigen Sie sich bei Ihrem ECLER-Händler oder auf www.ecler.com über die Wandgeräte zur Fernbedienung aus der Baureihe **WPa** und über alles weitere Zubehör für den Anschluss an REMOTE-/VCA-Ports.

5.9 GPO-Ports für Fernsteuerung

Die MIMO4040CDN verfügt an ihrer Rückseite über 8 Relaisausgänge NO/NC (normal open / normal closed). Jeder dieser Ausgänge kann durch Auslösen einer bestimmten, zuvor im EclerNet Manager programmierten Funktion, zum Beispiel ein Kalenderereignis oder das Drücken einer Taste des UCP-Bedienpanels, seinen Zustand ändern. Auf diese Weise ist das Zusammenspiel mit externen Geräten möglich, z.B. mit Antrieben von Projektionswänden oder beweglichen Trennwänden, mit Lichtern, Sirenen, GPI-Eingängen anderer Geräte usw.

6 ZU BEACHTENDE PUNKTE

6.1 Masseschleifen

Es ist stets darauf zu achten, dass die an der Matrix ankommenden Signalquellen sowie die Massen der Apparate, die an deren Ausgänge angeschlossen sind, getrennt sind, so dass ein Gerät nie mehr als einen Masseweg besitzt. Wäre dies der Fall, so könnte es zu unerwünschten Brummgeräuschen kommen, die sogar die Qualität der Klangwiedergabe beeinträchtigen könnten.

Sollten die Kabelabschirmungen mit dem Gehäuse verbunden sein, so dürfen sie auf keinen Fall untereinander verbunden sein. Auf diese Weise wird eine Bildung von Masseschleifen verhindert.

6.2 Hintergrundrauschen

Die MIMO4040CDN wurde unter dem Gesichtspunkt der weitestgehenden Vermeidung von Hintergrundrauschen konzipiert. Allerdings hängt das Hintergrundrauschen, unabhängig vom elektronischen Konzept, unmittelbar von der richtigen Handhabung und Installation des Geräts ab.

Es ist zum Beispiel nicht das Gleiche, ob der GAIN-Regler eines Kanals auf 2 steht und der Pegelregler VOL des entsprechenden Ausgangs auf Maximallautstärke (Fall 1), oder ob das Gain des Eingangssignals richtig eingestellt ist und der Pegelregler der entsprechenden Ausgangskanäle auf einer mittleren Position steht (Fall 2). Im ersten Fall ist das Signal, das am Mix-Verstärker ankommt und von Natur aus ein eigenes Hintergrundrauschen besitzt, schwach, wodurch das Verhältnis Signal/Rauschen niedrig ist (wenig Signal). Verstärkt nun der Ausgangsverstärker alles gleichermaßen, so haben wir am Ausgang ein sehr starkes Hintergrundrauschen.

Im zweiten Fall, bei dem das Eingangs-Gain richtig eingestellt ist, empfängt die Matrix ein starkes Signal und somit auch ein starkes Verhältnis Signal/Rauschen, so dass das Signal, wenn es an den Ausgangskanälen ankommt und verstärkt wird, ein besseres Verhältnis aufweist als im ersten Fall.

7 LIEFERUMFANG

- MIMO4040CDN
- AC-Versorgungskabel
- Euroblock-Stecker für analoge Audioein- und ausgänge und GPIO-Ports
- Kurze Bedienungsanleitung und Garantieschein

8 LISTE DER FUNKTIONEN

1. Stereo-Jack für Kopfhörer-Anschluss
2. Kopfhörer-Lautstärkeregelung, VOL
3. Leuchtanzeigen analoges Eingangssignal, INPUTS
4. Leuchtanzeigen analoges Ausgangssignal, OUTPUTS
5. Leuchtanzeige für Datenverkehr, DATA
6. Leuchtanzeige für digitalen DANTE Audioverkehr
7. Leuchtanzeige für Inbetriebsetzung, POWER
8. IEC-Anschluss für Kabel der externen AC-Versorgung
9. Sicherungshalter
10. Netzschalter des Geräts
11. Euroblock-Anschlüsse, Gleichstrom-Ansteuerung, GPI
12. Euroblock-Relais-Ausgangsanschlüsse, GPO
13. DANTE Ports, primär und sekundär, RJ45-Anschluss
14. Ethernet-Steuerungsport, RJ45-Anschluss
15. DB9-Anschluss für Fernsteuerung über TP-NET-Protokoll, RS-232
16. Analoge Euroblock-Audioausgangs-Anschlüsse, MONITOR
17. Analoge Euroblock-Audioausgangs-Anschlüsse, OUT
18. Analoge Euroblock-Audioeingangsanschlüsse, IN

9 FUNKTIONSDIAGRAMM

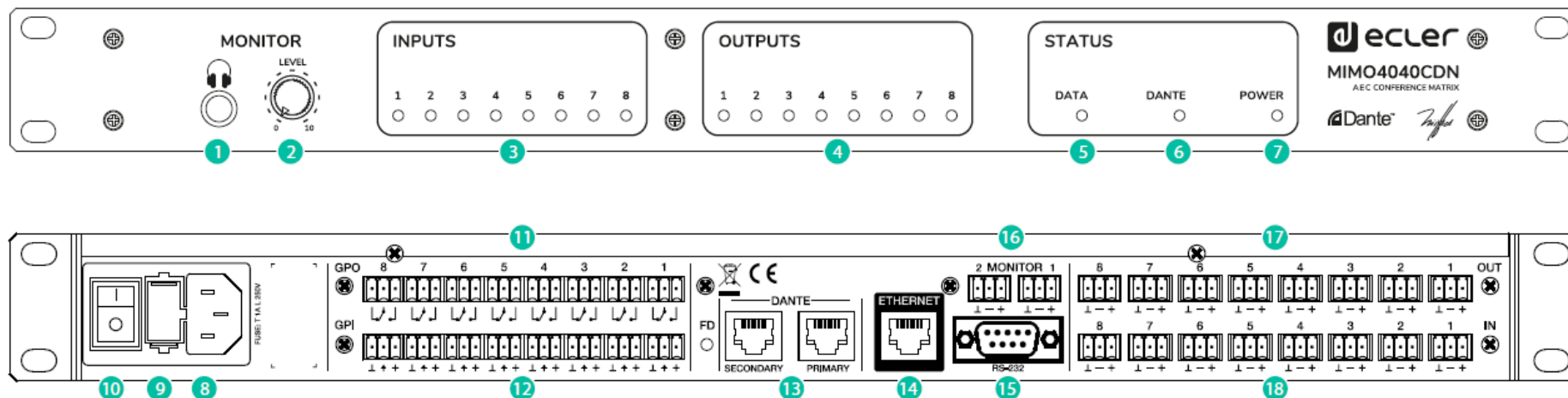

10 BLOCKDIAGRAMM

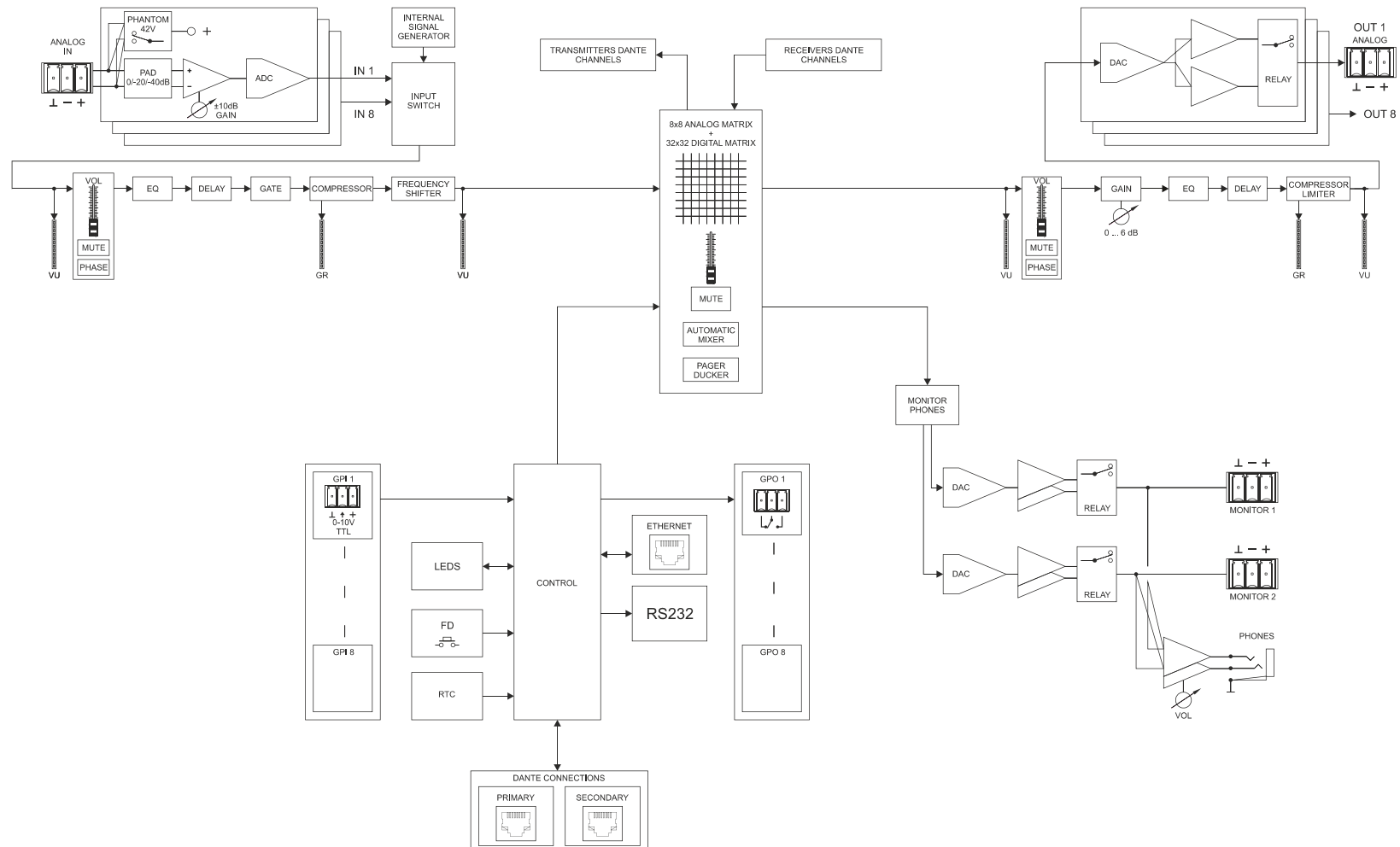

11 TECHNISCHE DATEN

MIMO4040CDN	
DSP	
CPU	Quad core 64bits 1GHz
Sampling rate	48 kHz
Latency analog IN to analog OUT	<4.3 ms.
Converters	
Resolution	24 bit
Dynamic range	AD:110dB, DA: 115dB
Analogue	
8 Input / Output	Terminal block (Symmetrical)
2 monitor output	Terminal block (Symmetrical)
Headphones connector	Jack ¼
Analogue input headroom	+27dBV = +30dBu
Max. output level	+18dBV = +21dBu
Input sensitivity @0dBV out	from -50dBV to +10dBV in 0.5dB steps
Input impedance	Balanced, >4kΩ
Phantom power	+42VDC, 5mA max. software switched
Headphones	>200mW/200Ω
Frequency response (-3dB)	5Hz to 24kHz
Flatness	better than ±0.1dB
THD+Noise @ 1kHz, 0dBV input (line)	<0.004%
THD+Noise @ 1kHz, -40dBV input (mic.)	<0.008%
Output Noise floor FFT (20Hz - 20kHz)	better than 115dB
Interchannel crosstalk (20Hz - 20kHz)	better than 90dB (100dB typ.)
Channel Leakage (20Hz - 20kHz)	better than 100dB (115dB typ.)
CMRR 20Hz- 20kHz	65dB typ.
Dante™/AES67 Audio interface	
Dante™/AES67 Network Tx / Rx channels	32 / 32
Latency	1 / 2 / 5 ms (selectable)
Connector	1xRJ45 primary, 1xRJ45 secondary
Cable length between devices	100m CAT5e/CAT6

Processing	
Input level (x40)	Range: from Off to 0 dB Mute: Yes Signal Polarity reverse: Yes Metering: VU+clip pre & post fader
Output level (x40)	Range: from Off to 0 dB Mute: Yes Solo: Yes Signal Polarity reverse: Yes Metering: VU+clip pre & post fader
Output gain (x40)	Range: from 0 to +6 dB
Input delay (x40)	from 0 to 1000 ms. Units: sec/ms/m/cm.
Output delay (x40)	from 0 to 1000 ms. Units: sec/ms/m/cm.
Parametric EQ types (4max/input - 8max/output)	Bypass / On-Off all channels Param Eq. Freq: 20Hz-20kHz; Gain: -60/+12 dB Q: 0.3 to 200 Low & High Shelf 6/12 dB/oct Low & High Pass 6/12 dB/oct All Pass 1/2 order
High & Low pass output X-over filters (x40)	Bypass On-Off Butterworth in 6/12/18/24 dB/oct Bessel in 12/18/24 dB/oct Linkwitz-Riley in 12/24 dB/oct
Input noise gate (x40)	Bypass On-Off Threshold: from -80 dBV to +18 dBV Depth: 0 dB to 80 dB Attack time: from 0,1 ms. to 500 ms. Hold time: from 10 ms. to 3000 ms. Release time: from 10 ms. to 1000 ms.
Input compressor / limiter (x40)	Bypass On-Off Threshold: from -36 dBV to +18 dBV Knee: hard / soft Ratio: inf:1 (limiter) Attack time: from 0,1 ms. to 500 ms. Release time: from 10 ms. to 1000 ms. Make up gain: from 0 to +10 dB
Input Frequency Shifter (x40) (Feedback Loop Reducer)	Per input. ON / OFF function
Output Limiter (x40)	Bypass On-Off Threshold: from -36 dBV to +18 dBV Attack time: from 0,1 ms. to 500 ms. Release time: from 10 ms. to 1000 ms.
Built in Signal Generator	Sine: from 20 Hz to 20 kHz Polarity: from 20 Hz to 20 kHz White noise Pink noise
Stereo Linking	Adjacent input / output channels Linked processing Matrix routing linked
Mix Matrix	Size: 40x40

Mechanical	
Dimensions	482,6 x 44,0 x 266,5mm / 19.0"x 1.7" x 10,5"
Weight	3,25kg / 7.17 lb.
Power supply	
Mains	90-264VCA 47-63Hz
Power consumption	30VA
Miscellaneous	
Management Connectivity	Ethernet Base-Tx 10 /100Mb, 1GB Auto X-Over CAT5e or better
GPI	8, from 0 to 12VDC or TTL level
GPO	8, 3 poles isolated relay; 1A, 48VDC max.
Aux. Power Supply for Remotes & GPI	+12VDC, 1.2A max. (short circuit protected)
Time and date retention (battery)	> 3 months
Programming and control application	
EclerNet Manager	From v6.00

TP-NET PROTOCOL

SOFTWARE

Third-Party NET

USER MANUAL

12 TP-NET PROTOCOL INTRODUCTION

The TP-NET protocol lets a client device (control device) get and/or set the values of several parameters of the **EclerNet compatible devices** (MIMO and MIMO SG series digital matrices, DUO-NET PLAYER, NXA digital audio manager series, NZA amplifier series, NPA amplifier series, etc.), like volumes, mutes, alarms, etc. It's as well available for **eMIMO1616 digital matrix**, **HUB series digital zoner**, **MIMO7272DN** and **MIMO4040CDN digital matrix**.

The communication with these digital audio devices can be established using Ethernet and the UDP/IP transport protocol, always by means of the **5800** UDP port.

A second option for this communication is using the RS-232 interface that some of these compatible devices do also have (MIMO series, DUO-NET PLAYER, NXA series, etc.). In this case, the serial connection must fulfil the following specifications:

- Baud rate: **57600** (fixed, no autonegotiation) for all the devices, except for DUO-NET PLAYER, eMIMO1616, HUB series and MIMO4040CDN, which use **115200** baud rate)
- Data bits: 8
- Parity: None
- Stop bits: 1
- Flow control: None

In case the Ecler device has an Euroblock connector for the RS-232 interface, the serial cable wiring, from the device's connector to a standard DB9 serial interface connector, must be the following:

WIRING RS232 – DB9	
RS232	DB9
Tx	Pin 2 (RxD)
Rx	Pin 3 (TxD)
Gnd	Pin 5 (Signal Gnd)

The protocol is simple and direct, making it easy to read, write and modify the generated code. It is based on messages with no begin and end delimiter: each message is self-delimited by the UDP packet size, which is defined with a maximum of **80 characters**. All the messages must be written in capital letters.

To let some control systems (like CRESTRON®, EXTRON®, AMX®, RTI®, VITY®, MEDIALON®, etc.) process the messages more easily, the EclerNet device adds the character **LF (0x0A)** to the end of each message. This way the client can buffer the

messages to process them, if it's required. The EclerNet device can also handle several messages received in a single message packet by using the **LF** delimiter.

The available messages are built with one or more fields separated with blank spaces (= blank space):

<TYPE> [PARAM1] [PARAM2] [PARAM3] [PARAM4][LF]

The first field (**TYPE**) defines the **message type** and then, the required parameters for it (each kind of message requires a given number of parameters). The field **TYPE** can have these values:

- **SYSTEM**
- **GET**
- **SET**
- **INC**
- **DEC**
- **SUBSCRIBE**
- **UNSUBSCRIBE**
- **DATA**
- **ERROR**

At the end of this document you'll find all the available messages and their parameters for each model of the EclerNet compatible devices.

The **SYSTEM, GET, SET, INC, DEC, SUBSCRIBE & UNSUBSCRIBE** messages can be sent from the client to the EclerNet device. The **DATA & ERROR** messages can be sent from the device to the client. The only exception is the **SYSTEM PING** message, that is a **SYSTEM** type message that is sent from the EclerNet device when the initial message from the client to the device was **SYSTEM CONNECT PINGPONG**.

The communication (using UDP or RS-232) starts when a client sends the message **SYSTEM CONNECT** to the EclerNet device. As far as the UDP communication requires no connection (unlike the TCP), the EclerNet device stores this client's IP address, and then uses it as the destination IP address for the messages that it generates (**DATA & ERROR**). After receiving the **SYSTEM CONNECT** message, the device dumps its entire configuration using several consecutive **DATA** messages.

The communication can be terminated by two methods:

- **Manually:** when the client sends the **SYSTEM DISCONNECT** message, cancelling all the subscriptions and stopping the **DATA** & **ERROR** messages
- **Automatically:** in case the initial message was **SYSTEM CONNECT PINGPONG** and the client didn't get any **SYSTEM PONG** message in a period longer than 10 seconds (presuming a communication breakdown)

The **SET** messages don't have an automatic acknowledgement with a **DATA** message sent from the EclerNet device after it has processed the **SET** command. The client must update the values itself and must send the needed **GET** message if it requires confirmation from the device.

NOTES:

- The numerical values are always integer numbers without +, -, comma or dot symbols.
- **[PINGPONG]** is an optional parameter used to configure the device-client communication with a periodical check, to see whether the client or the device have terminated it. When configured this way, the device sends a **SYSTEM PING** once per second, and the client must answer with a **SYSTEM PONG** message. If anyone doesn't get these messages along a 10 seconds period, the communication will be considered terminated
- **<Input Channel>** & **<Output Channel>** are numerical values that identify an input or output channel of the EclerNet device:
 - It can be within a [1..8] range for MIMO88 single units (8x8 matrix masters), and [1..16] for MIMO88 couples configured as 16x16 matrix masters
 - It can be within a [1..8] range for MIMO88SG units
 - It can be within a [1..12] range for MIMO1212SG units
 - For the NPA series, **<Output Channel>** can be within a [1..2] range
 - For the NXA and NZA series it can be within the [1..4] or [1..6] range, for 4 or 6 channel amplifiers
 - It can be within a [1..16] range for eMIMO1616 units
 - It can be within a [1..40] range for MIMO7272DN and MIMO4040CDN
- **<Preset Number>** is a numerical value that identifies one available Preset stored in the EclerNet device's memory:
 - For the MIMO series it can be within the [1..99] range
 - For the DUO-NET PLAYER it can be within the [1..20] range
 - For the NPA series it can be within the [1..10] range
 - For the NXA and NZA series it can be within the [1..5] range
- **<Level>**, **<Pre Vumeter Level>** y **<Post Vumeter Level>** are numerical values in the [0..100] range that define values in a scale equivalent to [-inf..0] dB

- **<GPI>** & **<GPO>** are numerical values within the [1..8] range for the MIMO88 configured as 8x8 matrix masters (single units), and [1..16] for MIMO88 couples configured as 16x16 matrix masters. For the NXA series GPI values can be within the [1..4] or [1..6] range, depending on model. For the MIMO7272DN and MIMO4040CDN GPI and GPO values can be within [1..8]
- **<GPI Value>** is a numerical value within the [0..100] range that indicates the value of an analogue GPI input. For a digital input only 0 or 100 are the possible values
- **<GPO Value>** is a numerical value within the [0..1] range: it can only be 0 or 1 (opened or closed GPO)
- **<Rate>** is a numerical value within the [1..10] range that sets the VU-meter refresh rate, or the number of times the vumeters' values are sent per second (by default = 3)
- **"<Device Name>"** is the device name inside double quotation marks, to allow for names with blank spaces
- **<Error ID>** is a numerical value for an error code
- **"<Error Description>"** is a text chain inside double quotation marks, containing an error description
- **<Virtual Control>** is a numerical value that identifies a Virtual Control in a MIMO or NXA device:
 - It can be within a [1A..4A] or [1B..4B] range for NXA 4 ch. Models
 - It can be within a [1A..6A] or [1B..6B] range for NXA 6 ch. models
 - It can be within a [1..64] range for MIMO88, MIMO88CONF, MIMO88SG, MIMO88SGCONF, MIMO1616, MIMO1616CONF, MIMO1212SG and MIMO1212SGCONF models
 - It can be within a [1..80] range for MIMO4040CDN model
 - It can be within a [1..160] range for MIMO7272DN model

13 NXA DIGITAL AUDIO MANAGER SERIES

IMPORTANT NOTE: The communication must be started with the client sending **the first message SYSTEM CONNECT** to the EclerNet device. Otherwise, the commands from the client to the EclerNet device will be ignored. See [TP-NET PROTOCOL INTRODUCTION chapter](#) for additional information.

TYPE	PARAM1	PARAM2	PARAM3	PARAM4	DESCRIPTION
SYSTEM	CONNECT	[PINGPONG]			Saves the client IP address for responses and then dumps current device status (with DATA messages)
	DISCONNECT				Cancel subscriptions and terminates communication
	SUBSCRIPTION_RATE	<Rate>			Alive message from device
	PING				Alive message from device
	PONG				Alive ACK message from client
GET	ALL				Dumps current device status (with DATA messages)
	POWER				Gets the Device Power status
	PRESET				Gets the current PRESET
	OLEVEL	<Output Channel>			Gets the current LEVEL of an Output Channel
	XLEVEL	<Input Channel>	<Output Channel>		Gets the current LEVEL of a Matrix point
	OMUTE	<Output Channel>			Gets the current MUTE status of an Output Channel
	XMUTE	<Input Channel>	<Output Channel>		Gets the current MUTE status of a Matrix Point
	OVU	<Output Channel>			Gets the VU-meter value of an Output Channel
	ALARM_PROTECT	<Output Channel>			Gets the Protect alarm status of an Output Channel

	ALARM_FAULT	<Output Channel>			Gets the self-diagnosis system alarm status of an Output Channel
	INFO_NAME				Gets the Device Name
	INFO_MODEL				Gets the Device Model
	INFO_VERSION				Gets the Firmware Version
	INFO_MAC				Gets the Device MAC address
	VIRTUAL_CONTROL	<Virtual Control>			Gets the Virtual Control value

TYPE	PARAM1	PARAM2	PARAM3	PARAM4	DESCRIPTION
SET	POWER	ON/OFF			Sets the Device Power status
	PRESET	<Preset Number>			Sets the current PRESET
	OLEVEL	<Output Channel>	<Level>		Sets the current LEVEL of an Output Channel
	XLEVEL	<Input Channel>	<Output Channel>	<Level>	Sets the current LEVEL of a Matrix point
	OMUTE	<Output Channel>	YES/NO		Sets the current MUTE status of an Output Channel
	XMUTE	<Input Channel>	<Output Channel>		Sets the current MUTE status of a Matrix Point
	VIRTUAL_CONTROL	<Virtual Control>	<Value>		Sets the Virtual Control value (Value can range from 1 to 100)
INC	OLEVEL	<Output Channel>	<Value>		Increases the current LEVEL of an Output Channel by Value (Value can range from ± 1 to ± 100)
	XLEVEL	<Input Channel>	<Output Channel>	<Value>	Increases the current LEVEL of a Matrix point by Value (Value can range from ± 1 to ± 100)
DEC	OLEVEL	<Output Channel>	<Value>		Decreases the current LEVEL of an Output Channel by Value (Value can range from ± 1 to ± 100)
	XLEVEL	<Input Channel>	<Output Channel>	<Value>	Decreases the current LEVEL of a Matrix point by Value (Value can range from ± 1 to ± 100)
SUBSCRIBE	ALL				Subscribes to all VU-meters
	OVU	<Output Channel>			Subscribes to an Output Channel VU-meter
UNSUBSCRIBE	ALL				Unsubscribe to all VU-meters
	OVU	<Output Channel>			Unsubscribe to an Output Channel VU-meter
DATA	POWER	ON/OFF			Shows the Device Power status
	PRESET	<Preset Number>			Shows the current PRESET
	OLEVEL	<Output Channel>	<Level>		Shows the current LEVEL of an Output Channel

	XLEVEL	<Input Channel>	<Output Channel>	<Level>	Shows the current LEVEL of a Matrix point
	OMUTE	<Output Channel>	YES/NO		Shows the current MUTE status of an Output Channel
	XMUTE	<Input Channel>	<Output Channel>	YES/NO	Shows the current MUTE status of a Matrix point
	VIRTUAL_CONTROL	<Virtual Control>	<Value>		Shows the Virtual Control value
	OVU	<Output Channel>	<Pre Vumeter Level>	<Post Vumeter Level>	Shows the VU-meter value of an Output Channel
	ALARM_PROTECT	<Output Channel>	ON/OFF		Shows the Protect alarm status of an Output Channel
	ALARM_FAULT	<Output Channel>	ON/OFF		Shows the self-diagnosis system alarm status of an Output Channel
	INFO_NAME	"<Device Name>"			Shows the Device Name
	INFO_MODEL	<Device Model>			Shows the Device Model
	INFO_VERSION	<Firmware Version>			Shows the Firmware Version
	INFO_MAC	<Device MAC address>			Shows the Device MAC address
ERROR	<Error ID>	"<Error Description>"			Informs about an error

Note: INC and DEC commands are replied with a DATA command from the device with the resulting LEVEL value, after it has been increased or decreased. When the INC or DEC command tries to adjust a LEVEL value beyond its minimum or maximum limits, no reply (DATA command) will be produced.

14 NZA MULTICHANNEL AMPLIFIER SERIES

IMPORTANT NOTE: The communication must be started with the client sending **the first message SYSTEM CONNECT** to the EclerNet device. Otherwise, the commands from the client to the EclerNet device will be ignored. See [TP-NET PROTOCOL INTRODUCTION](#) chapter for additional information.

TYPE	PARAM1	PARAM2	PARAM3	PARAM4	DESCRIPTION
SET	POWER	ON/OFF			Sets the Device Power status
	PRESET	<Preset Number>			Sets the current PRESET
	OLEVEL	<Output Channel>	<Level>		Sets the current LEVEL of an Output Channel
	OMUTE	<Output Channel>	YES/NO		Sets the current MUTE status of an Output Channel
SUBSCRIBE	ALL				Subscribes to all VU-meters
	OVU	<Output Channel>			Subscribes to an Output Channel VU-meter
UNSUBSCRIBE	ALL				Unsubscribe to all VU-meters
	OVU	<Output Channel>			Unsubscribe to an Output Channel VU-meter
DATA	POWER	ON/OFF			Shows the Device Power status
	PRESET	<Preset Number>			Shows the current PRESET
	OLEVEL	<Output Channel>	<Level>		Shows the current LEVEL of an Output Channel
	OMUTE	<Output Channel>	YES/NO		Shows the current MUTE status of an Output Channel
	OVU	<Output Channel>	<Pre Vumeter Level>	<Post Vumeter Level>	Shows the VU-meter value of an Output Channel
	ALARM_PROTECT	<Output Channel>	ON/OFF		Shows the Protect alarm status of an Output Channel
	INFO_NAME	"<Device Name>"			Shows the Device Name
	INFO_MODEL	<Device Model>			Shows the Device Model
	INFO_VERSION	<Firmware Version>			Shows the Firmware Version
INFO_MAC	<Device MAC address>			Shows the Device MAC address	

ERROR	<Error ID>	“<Error Description>”			Informs about an error
--------------	------------	-----------------------	--	--	------------------------

15 NPA STEREO AMPLIFIER SERIES

IMPORTANT NOTE: The communication must be started with the client sending **the first message SYSTEM CONNECT** to the EclerNet device. Otherwise, the commands from the client to the EclerNet device will be ignored. See [TP-NET PROTOCOL INTRODUCTION chapter](#) for additional information.

TYPE	PARAM1	PARAM2	PARAM3	PARAM4	DESCRIPTION
SYSTEM	CONNECT	[PINGPONG]			Saves the client IP address for responses and then dumps current device status (with DATA messages)
	DISCONNECT				Cancel subscriptions and terminates communication
	SUBSCRIPTION_RATE	<Rate>			Alive message from device
	PING				Alive message from device
	PONG				Alice ACK message from client
GET	ALL				Dumps current device status (with DATA messages)
	POWER				Gets the Device Power status
	PRESET				Gets the current PRESET
	OLEVEL	<Output Channel>			Gets the current LEVEL of an Output Channel
	OMUTE	<Output Channel>			Gets the current MUTE status of an Output Channel
	OVU	<Output Channel>			Gets the VU-meter value of an Output Channel
	ALARM_PROTECT	<Output Channel>			Gets the Protect alarm status of an Output Channel
	ALARM_THERMAL	<Output Channel>			Gets the Thermal alarm status of an Output Channel

	ALARM_LOAD	<Output Channel>			Gets the Load alarm status of an Output Channel
	ALARM_VOLTAGE				Gets the Voltage alarm status of the Device
	INFO_NAME				Gets the Device Name
	INFO_MODEL				Gets the Device Model
	INFO_VERSION				Gets the Firmware Version
	INFO_MAC				Gets the Device MAC address

TYPE	PARAM1	PARAM2	PARAM3	PARAM4	DESCRIPTION
SET	POWER	ON/OFF			Sets the Device Power status
	PRESET	<Preset Number>			Sets the current PRESET
	OLEVEL	<Output Channel>	<Level>		Sets the current LEVEL of an Output Channel
	OMUTE	<Output Channel>	YES/NO		Sets the current MUTE status of an Output Channel
SUBSCRIBE	ALL				Subscribes to all VU-meters
	OVU	<Output Channel>			Subscribes to an Output Channel VU-meter
UNSUBSCRIBE	ALL				Unsubscribe to all VU-meters
	OVU	<Output Channel>			Unsubscribe to an Output Channel VU-meter
DATA	POWER	ON/OFF			Shows the Device Power status
	PRESET	<Preset Number>			Shows the current PRESET
	OLEVEL	<Output Channel>	<Level>		Shows the current LEVEL of an Output Channel
	OMUTE	<Output Channel>	YES/NO		Shows the current MUTE status of an Output Channel
	OVU	<Output Channel>	<Pre Vumeter Level>	<Post Vumeter Level>	Shows the VU-meter value of an Output Channel

	ALARM_PROTECT	<Output Channel>	ON/OFF		Shows the Protect alarm status of an Output Channel
	ALARM_THERMAL	<Output Channel>	ON/OFF		Shows the Thermal alarm status of an Output Channel
	ALARM_LOAD	<Output Channel>	ON/OFF		Shows the Load alarm status of an Output Channel
	ALARM_VOLTAGE	ON/OFF			Shows the Voltage alarm status of the Device
	INFO_NAME	"<Device Name>"			Shows the Device Name
	INFO_MODEL	<Device Model>			Shows the Device Model
	INFO_VERSION	<Firmware Version>			Shows the Firmware Version
	INFO_MAC	<Device MAC address>			Shows the Device MAC address
ERROR	<Error ID>	"<Error Description>"			Informs about an error

16 MIMO88 / MIMO88 CONFERENCE / MIMO88SG / MIMO1212SG (SINGLE) DIGITAL MATRIX

IMPORTANT NOTE: The communication must be started with the client sending **the first message SYSTEM CONNECT** to the EclerNet device. Otherwise, the commands from the client to the EclerNet device will be ignored. See [TP-NET PROTOCOL INTRODUCTION](#) chapter for additional information.

TYPE	PARAM1	PARAM2	PARAM3	PARAM4	DESCRIPTION
SYSTEM	CONNECT	[PINGPONG]			Saves the client IP address for responses and then dumps current device status (with DATA messages)
	DISCONNECT				Cancel subscriptions and terminates communication
	SUBSCRIPTION_RATE	<Rate>			Alive message from device
	PING				Alive message from device
	PONG				Alive ACK message from client
GET	ALL				Dumps current device status (with DATA messages)
	PRESET				Gets the current PRESET
	ILEVEL	<Input Channel>			Gets the current LEVEL of an Input Channel
	OLEVEL	<Output Channel>			Gets the current LEVEL of an Output Channel
	XLEVEL	<Input Channel>	<Output Channel>		Gets the current LEVEL of a Matrix point
	IMUTE	<Input Channel>			Gets the current MUTE status of an Input Channel
	OMUTE	<Output Channel>			Gets the current MUTE status of an Output Channel
	XMUTE	<Input Channel>	<Output Channel>		Gets the current MUTE status of a Matrix Point
	IVU	<Input Channel>			Gets the VU-meter value of an Input Channel

	OVU	<Output Channel>			Gets the VU-meter value of an Output Channel
	GPI	<Input>			Gets the current value of a General Purpose Input
	GPO	<Output>			Gets the current value of a General Purpose Output (not valid for MIMO88SG / MIMO1212SG)
	INFO_NAME				Gets the Device Name
	INFO_MODEL				Gets the Device Model
	INFO_VERSION				Gets the Firmware Version
	INFO_MAC				Gets the Device MAC address
	VIRTUAL_CONTROL	<Virtual Control>			Gets the Virtual Control value

TYPE	PARAM1	PARAM2	PARAM3	PARAM4	DESCRIPTION
SET	PRESET	<Preset Number>			Sets the current PRESET
	ILEVEL	<Input Channel>	<Level>		Sets the current LEVEL of an Input Channel
	OLEVEL	<Output Channel>	<Level>		Sets the current LEVEL of an Output Channel
	XLEVEL	<Input Channel>	<Output Channel>	<Level>	Sets the current LEVEL for a Matrix point
	IMUTE	<Input Channel>	YES/NO		Sets the current MUTE status of an Input Channel
	OMUTE	<Output Channel>	YES/NO		Sets the current MUTE status of an Output Channel
	XMUTE	<Input Channel>	<Output Channel>	YES/NO	Sets the current MUTE status for a Matrix Point
	GPO	<Output>	<GPO Value>		Sets the current value for a General Purpose Output (not valid for MIMO88SG)
	VIRTUAL_CONTROL	<Virtual Control>	<Value>		Sets the Virtual Control value (Value can range from 1 to 100)
INC	ILEVEL	<Input Channel >	<Value>		Increases the current LEVEL of an Input Channel by Value (Value can range from ± 1 to ± 100)
	OLEVEL	<Output Channel>	<Value>		Increases the current LEVEL of an Output Channel by Value (Value can range from ± 1 to ± 100)
	XLEVEL	<Input Channel>	<Output Channel>	<Value>	Increases the current LEVEL of a Matrix point by Value (Value can range from ± 1 to ± 100)
DEC	ILEVEL	<Input Channel >	<Value>		Decreases the current LEVEL of an Input Channel by Value (Value can range from ± 1 to ± 100)
	OLEVEL	<Output Channel>	<Value>		Decreases the current LEVEL of an Output Channel by Value (Value can range from ± 1 to ± 100)

	XLEVEL	<Input Channel>	<Output Channel>	<Value>	Decreases the current LEVEL of a Matrix point by Value (Value can range from ± 1 to ± 100)
SUBSCRIBE	ALL				Subscribes to all VU-meters
	IVU	<Input Channel>			Subscribes to an Input Channel VU-meter
	OVU	<Output Channel>			Subscribes to an Output Channel VU-meter
UNSUBSCRIBE	ALL				Unsubscribe to all VU-meters
	IVU	<Input Channel>			Unsubscribe to an Input Channel VU-meter
	OVU	<Output Channel>			Unsubscribe to an Output Channel VU-meter

Note: **INC** and **DEC** commands are replied with a **DATA** command from the device with the resulting LEVEL value, after it has been increased or decreased. When the **INC** or **DEC** command tries to adjust a LEVEL value beyond its minimum or maximum limits, no reply (**DATA** command) will be produced.

TYPE	PARAM1	PARAM2	PARAM3	PARAM4	DESCRIPTION
DATA	PRESET	<Preset Number>			Shows the current PRESET
	ILEVEL	<Input Channel>	<Level>		Shows the current LEVEL of an Input Channel
	OLEVEL	<Output Channel>	<Level>		Shows the current LEVEL of an Output Channel
	XLEVEL	<Input Channel>	<Output Channel>	<Level>	Shows the current LEVEL for a Matrix point
	IMUTE	<Input Channel>	YES/NO		Shows the current MUTE status of an Input Channel
	OMUTE	<Output Channel>	YES/NO		Shows the current MUTE status of an Output Channel
	XMUTE	<Input Channel>	<Output Channel>	YES/NO	Shows the current MUTE status for a Matrix Point
	VIRTUAL_CONTROL	<Virtual Control>	<Value>		Shows the Virtual Control value (Value can range from 1 to 100)
	IVU	<Input Channel>	<Pre Vumeter Level>	<Post Vumeter Level>	Shows the VU-meter value of an Input Channel
	OVU	<Output Channel>	<Pre Vumeter Level>	<Post Vumeter Level>	Shows the VU-meter value of an Output Channel
	GPI	<Input>	<GPI Value>		Shows the current value of a General Purpose Input
	GPO	<Output>	<GPO Value>		Shows the current value of a General Purpose Output. (not valid for MIMO88SG)
	INFO_NAME	"<Device Name>"			Shows the Device Name
	INFO_MODEL	<Device Model>			Shows the Device Model
INFO_VERSION	<Firmware Version>			Shows the Firmware Version	
INFO_MAC	<Device MAC address>			Shows the Device MAC address	
ERROR	<Error ID>	"<Error Description>"			Informs about an error

17 MIMO88SG CONFERENCE DIGITAL MATRIX

IMPORTANT NOTE: The communication must be started with the client sending **the first message SYSTEM CONNECT** to the EclerNet device. Otherwise, the commands from the client to the EclerNet device will be ignored. See [TP-NET PROTOCOL INTRODUCTION](#) chapter for additional information.

This MIMO88SG CONFERENCE firmware version shares the same hardware with the standard MIMO88SG unit, just uploading the CONFERENCE firmware version to it, and shares as well the same TP-NET commands in the above table, adding to them these new ones:

TYPE	PARAM1	PARAM2	PARAM3	PARAM4	DESCRIPTION
GET	GATE				Gets the current status of the NOISE GATE for inputs 1 to 8
	AUTOMIXER				Gets the current status of the AUTOMIXER function for inputs 1 to 8
SUBSCRIBE	GATE				Subscribes to the status of the NOISE GATE for inputs 1 to 8
	AUTOMIXER				Subscribes to the status of the AUTOMIXER function for inputs 1 to 8
UNSUBSCRIBE	GATE				Unsubscribes to the status of the NOISE GATE for inputs 1 to 8
	AUTOMIXER				Unsubscribes to the status of the AUTOMIXER function for inputs 1 to 8
DATA	GATE	s1 s2 s3 s4 s5 s6 s7 s8			Shows the current NOISE GATE status (0 = open / 1 = closed) for the 8 inputs channels (s1 to s8, status of the gate for inputs 1 to 8)
	AUTOMIXER	s1 s2 s3 s4 s5 s6 s7 s8			Shows the current status for input channels in the Automixer section (0 = disabled or bellow threshold in the automixer / 1 = enabled and beyond threshold, but queued, not in the automatic mix / 2 = enabled, beyond threshold and into the automatic mix) for the 8 inputs channels (s1 to s8, status of the automixer function for inputs 1 to 8)

18 MIMO 7272DN / MIMO4040CDN DIGITAL MATRIX

IMPORTANT NOTE: The communication must be started with the client sending **the first message SYSTEM CONNECT** to the EclerNet device. Otherwise, the commands from the client to the EclerNet device will be ignored. See [TP-NET PROTOCOL INTRODUCTION](#) chapter for additional information.

TYPE	PARAM1	PARAM2	PARAM3	PARAM4	DESCRIPTION
SYSTEM	CONNECT	[MASTER]	[PINGPONG]	[ONCE]	Saves the client IP address for responses and then dumps current device status (with DATA messages)
	DISCONNECT				Cancel subscriptions and terminates communication
	SUBSCRIPTION_RATE	<Rate>			Alive message from device
	PING				Alive message from device
	PONG				Alive ACK message from client
	PING INTERVAL	<1-1000>			Ping Interval, in seconds
GET	ALL				Dumps current device status (with DATA messages)
	PRESET				Gets the current PRESET
	ILEVEL	<Input Channel>			Gets the current LEVEL of an Input Channel
	OLEVEL	<Output Channel>			Gets the current LEVEL of an Output Channel
	XLEVEL	<Input Channel>	<Output Channel>		Gets the current LEVEL of a Matrix point
	IMUTE	<Input Channel>			Gets the current MUTE status of an Input Channel
	XMUTE	<Input Channel>	<Output Channel>		Gets the current MUTE status of a Matrix Point
	IVU	<Input Channel>			Gets the VU-meter value of an Input Channel
	OVU	<Output Channel>			Gets the VU-meter value of an Output Channel

	GPI	<Input>			Gets the current value of a General Purpose Input
	GPO	<Output>			Gets the current value of a General Purpose Output
	INFO_NAME				Gets the Device Name
	INFO_MODEL				Gets the Device Model
	INFO_VERSION				Gets the Firmware Version
	INFO_MAC				Gets the Device MAC address
	VIRTUAL_CONTROL	<Virtual Control>			Gets the Virtual Control value

TYPE	PARAM1	PARAM2	PARAM3	PARAM4	DESCRIPTION
SET	PRESET	<Preset Number>			Sets the current PRESET
	ILEVEL	<Input Channel>	<Level>		Sets the current LEVEL of an Input Channel
	OLEVEL	<Output Channel>	<Level>		Sets the current LEVEL of an Output Channel
	XLEVEL	<Input Channel>	<Output Channel>	<Level>	Sets the current LEVEL for a Matrix point
	IMUTE	<Input Channel>	YES/NO		Sets the current MUTE status of an Input Channel
	XMUTE	<Input Channel>	<Output Channel>	YES/NO	Sets the current MUTE status for a Matrix Point
	GPO	<Output>	<GPO Value>		Sets the current value for a General Purpose Output
	VIRTUAL_CONTROL	<Virtual Control>	<Value>		Sets the Virtual Control value (Value can range from 1 to 100)
INC	ILEVEL	<Input Channel >	<Value>		Increases the current LEVEL of an Input Channel by Value (Value can range from ± 1 to ± 100)
	OLEVEL	<Output Channel>	<Value>		Increases the current LEVEL of an Output Channel by Value (Value can range from ± 1 to ± 100)
	XLEVEL	<Input Channel>	<Output Channel>	<Value>	Increases the current LEVEL of a Matrix point by Value (Value can range from ± 1 to ± 100)
DEC	ILEVEL	<Input Channel >	<Value>		Decreases the current LEVEL of an Input Channel by Value (Value can range from ± 1 to ± 100)
	OLEVEL	<Output Channel>	<Value>		Decreases the current LEVEL of an Output Channel by Value (Value can range from ± 1 to ± 100)
	XLEVEL	<Input Channel>	<Output Channel>	<Value>	Decreases the current LEVEL of a Matrix point by Value (Value can range from ± 1 to ± 100)
SUBSCRIBE	ALL				Subscribes to all VU-meters

	IVU	<Input Channel>			Subscribes to an Input Channel VU-meter
	OVU	<Output Channel>			Subscribes to an Output Channel VU-meter
UNSUBSCRIBE	ALL				Unsubscribe to all VU-meters
	IVU	<Input Channel>			Unsubscribe to an Input Channel VU-meter
	OVU	<Output Channel>			Unsubscribe to an Output Channel VU-meter

Note: **INC** and **DEC** commands are replied with a **DATA** command from the device with the resulting LEVEL value, after it has been increased or decreased. When the **INC** or **DEC** command tries to adjust a LEVEL value beyond its minimum or maximum limits, no reply (**DATA** command) will be produced.

TYPE	PARAM1	PARAM2	PARAM3	PARAM4	DESCRIPTION
DATA	PRESET	<Preset Number>			Shows the current PRESET
	ILEVEL	<Input Channel>	<Level>		Shows the current LEVEL of an Input Channel
	OLEVEL	<Output Channel>	<Level>		Shows the current LEVEL of an Output Channel
	XLEVEL	<Input Channel>	<Output Channel>	<Level>	Shows the current LEVEL for a Matrix point
	IMUTE	<Input Channel>	YES/NO		Shows the current MUTE status of an Input Channel
	XMUTE	<Input Channel>	<Output Channel>	YES/NO	Shows the current MUTE status for a Matrix Point
	VIRTUAL_CONTROL	<Virtual Control>	<Value>		Shows the Virtual Control value (Value can range from 1 to 100)
	IVU	<Input Channel>	<Pre Vumeter Level>	<Post Vumeter Level>	Shows the VU-meter value of an Input Channel
	OVU	<Output Channel>	<Pre Vumeter Level>	<Post Vumeter Level>	Shows the VU-meter value of an Output Channel
	GPI	<Input>	<GPI Value>		Shows the current value of a General Purpose Input
	GPO	<Output>	<GPO Value>		Shows the current value of a General Purpose Output.
	INFO_NAME	"<Device Name>"			Shows the Device Name
	INFO_MODEL	<Device Model>			Shows the Device Model
	INFO_VERSION	<Firmware Version>			Shows the Firmware Version
	INFO_MAC	<Device MAC address>			Shows the Device MAC address
INFO IPLIST				Shows the list of clients connected to the Device. The message will contain a list including ClientNumber ClientIP Client Port (separated by blank characters)	

18.1 MIMO4040CDN: AEC MANAGEMENT

TYPE	PARAM1	PARAM2	PARAM3	PARAM4	DESCRIPTION
GET	AEC_MIC_LEVEL	<Room>	<Mic>		Gets the current LEVEL of a local mic from a given AEC room
	AEC_MIC_MUTE	<Room>	<Mic>	YES/NO	Gets the current MUTE status of a local mic from a given AEC room
	AEC_MIC_VU	<Room>	<Mic>		Gets the VU-meter value of a of a local mic from a given AEC room. It returns the Pre Fader and Post Fader values
	AEC_SPK_LEVEL	<Room>	<Speaker>		Gets the current LEVEL of a local loudspeaker from a given AEC room
	AEC_SPK_MUTE	<Room>	<Speaker>	YES/NO	Gets the current MUTE status of a local loudspeaker from a given AEC room
	AEC_SPK_VU	<Room>	<Speaker>		Gets the VU-meter value of a local loudspeaker from a given AEC room. It returns the Pre Fader and Post Fader values
SET	AEC_MIC_LEVEL	<Room>	<Mic>	<Value>	Sets the current LEVEL of a local mic from a given AEC room
	AEC_MIC_MUTE	<Room>	<Mic>	YES/NO	Sets the current MUTE status of a local mic from a given AEC room
	AEC_SPK_LEVEL	<Room>	<Speaker>	<Value>	Sets the current LEVEL of a local loudspeaker from a given AEC room
	AEC_SPK_MUTE	<Room>	<Speaker>	YES/NO	Sets the current MUTE status of a local loudspeaker from a given AEC room
	AEC_RESET	<Room>			Reset the AEC algorithm (default parameters) from a given AEC room

INC	AEC_MIC_LEVEL	<Room>	<Mic>	<Value>	Increases the current LEVEL of a local mic from a given AEC room (Value can range from ± 1 to ± 100)
	AEC_SPK_LEVEL	<Room>	<Speaker>	<Value>	Increases the current LEVEL of a local loudspeaker from a given AEC room (Value can range from ± 1 to ± 100)
DEC	AEC_MIC_LEVEL	<Room>	<Mic>	<Value>	Decreases the current LEVEL of a local mic from a given AEC room (Value can range from ± 1 to ± 100)
	AEC_SPK_LEVEL	<Room>	<Speaker>	<Value>	Decreases the current LEVEL of a local loudspeaker from a given AEC room (Value can range from ± 1 to ± 100)
SUBSCRIBE	AEC_MIC_VU	<Room>	<Mic>		Subscribe to all VU-meters of a local mic from a given AEC room
	AEC_SPK_VU	<Room>	<Speaker>		Subscribe to all VU-meters of a local loudspeaker from a given AEC room
UNSUBSCRIBE	AEC_MIC_VU	<Room>	<Mic>		Unsubscribe to all VU-meters of a local mic from a given AEC room
	AEC_SPK_VU	<Room>	<Speaker>		Unsubscribe to all VU-meters of a local loudspeaker from a given AEC room

19 DUO-NET PLAYER AUDIO PLAYER & STREAMING RECEIVER

IMPORTANT NOTE: The communication must be started with the client sending **the first message SYSTEM CONNECT** to the EclerNet device. Otherwise, the commands from the client to the EclerNet device will be ignored. See [TP-NET PROTOCOL INTRODUCTION](#) chapter for additional information.

TYPE	PARAM1	PARAM2	PARAM3	PARAM4	DESCRIPTION
SYSTEM	CONNECT	[PINGPONG]			Saves the client IP address for responses and then dumps current device status (with DATA messages)
	DISCONNECT				Cancel subscriptions and terminates communication
	SUBSCRIPTION_RATE	<Rate>			Alive message from device
	PING				Alive message from device
	PONG				Alive ACK message from client
	PING_INTERVAL				
GET	ALL				Dumps current device status (with DATA messages)
	PRESET_INDEX				Gets the current PRESET number
	PRESET_NAME				Gets the current PRESET name
	DEVICE_NAME				Gets the Device Name
	INFO_MODEL				Gets the Device Model
	INFO_VERSION				Gets the Firmware Version
	INFO_MAC				Gets the Device MAC address
	INFO_IPLIST				Gets the IP parameters of the connected client devices
	IP_CONFIG				Shows the DUO-NET unit's current IP configuration
	PLAYER_NAME	<PLAYER:A/B>			Gets the PLAYER A or B NAME
PLAYER_MUTE	<PLAYER:A/B>			Gets the MUTE status of PLAYER A or B	

PLAYER_VOLUME	<PLAYER:A/B>			Gets the VOLUME level of PLAYER A or B
PLAYER_VUMETER	<PLAYER:A/B>			Gets the VUMETER level of PLAYER A or B
PLAYER_TIME	<PLAYER:A/B>			Gets PLAYER A or B elapsed, remaining and total time of the current media playback
PLAYER_TRANSPORT_STATUS	<PLAYER:A/B>			Gets PLAYER A or B current playback status
PLAYER_PLAYLIST_INDEX				Gets PLAYER A or B loaded playlist number, from the 99 available in the playlist bank
PLAYER_PLAYLIST_NAME	<PLAYER:A/B>			Gets PLAYER A or B loaded playlist name, from the 99 available in the playlist bank
PLAYER_QUEUE_INFO	<PLAYER:A/B>			Gets PLAYER A or B current playback queue position (index) and total number of items in it (count)
PLAYER_PLAY_MODE	<PLAYER:A/B>			Gets PLAYER A or B current playback order mode
PLAYER_REPEAT_MODE	<PLAYER:A/B>			Gets PLAYER A or B current playback repeat mode
PLAYER_FADE_MODE	<PLAYER:A/B>			Gets PLAYER A or B current tracks playback transition mode
PLAYER_VARISPEED	<PLAYER:A/B>			Gets PLAYER A or B current playback tempo variation value
PRIORITY_STATUS	<PRIORITY:1/2>			Gets PRIORITY MODULE 1 or 2 status
PLAYER_ITEM_TAGS	<PLAYER:A/B>			Gets PLAYER A or B current playback ALIAS, TITLE, ARTIST, ALBUM and NAME tags

SET	PRESET_INDEX	<1..20>			Sets the current PRESET number
	PLAYER_MUTE	<PLAYER:A/B>	<YES/NO>		Sets the MUTE status of PLAYER A or B
	PLAYER_VOLUME	<PLAYER:A/B>	<0..100>		Sets the VOLUME level of PLAYER A or B
	PLAYER_TRANSPORT_CONTROL	<PLAYER:A/B>	<STOP/PLAY/PAUSE/NEXT/PREV>		Sets PLAYER A or B transport controls
	PLAYER_PLAYLIST_INDEX	<PLAYER:A/B>	<1..99>		Sets (loads) PLAYER A or B playlist number, from the 99 available in the playlist bank
	PLAYER_PLAY_MODE	<PLAYER:A/B>	<SEQUENTIAL/RANDOM>		Sets PLAYER A or B playback order mode
	PLAYER_REPEAT_MODE	<PLAYER:A/B>	<PLAY_ALL/PLAY_ONE/REPEAT_ALL/REPEAT_ONE>		Sets PLAYER A or B current playback repeat mode
	PLAYER_FADE_MODE	<PLAYER:A/B>	<NONE/XFADE/FADE/HFADE>		Sets PLAYER A or B current tracks playback transition mode
	PLAYER_VARISPEED	<PLAYER:A/B>	<VARISPEED:-50..50>		Sets the current Varispeed (track's tempo) variation value, from -50% to +50%
INC	PLAYER_VOLUME	PLAYER:A/B>	<0..100>		INCREASES the current VOLUME of a PLAYER, a value from ± 1 to ± 100
	PLAYER_VARISPEED	PLAYER:A/B>	<VARISPEED:-50..50>		INCREMENTS the current Varispeed (track's tempo) variation value, from -50% to +50%
DEC	PLAYER_VOLUME	PLAYER:A/B>	<0..100>		DECREASES the current VOLUME of a PLAYER, a value from ± 1 to ± 100
	PLAYER_VARISPEED	PLAYER:A/B>	<VARISPEED:-50..50>		DECREMENTS the current Varispeed (track's tempo) variation value, from -50% to +50%
SUBSCRIBE	ALL				Subscribes to all VU-meters and player times
	PLAYER_VUMETER	PLAYER:A/B>			Subscribes to the VUMETER level of PLAYER A or B
	PLAYER_TIME	PLAYER:A/B>			Subscribes to the TIME values (elapsed, remaining, total) of PLAYER A or B

UNSUBSCRIBE	ALL				Unsubscribes to all VU-meters and player times
	PLAYER_VUMETER	PLAYER:A/B>			Unsubscribes to the VUMETER level of PLAYER A or B
	PLAYER_TIME	PLAYER:A/B>			Unsubscribes to the TIME values (elapsed, remaining, total) of PLAYER A or B

DATA	PRESET_INDEX	<1..20>			Shows the current PRESET number
	PRESET_NAME	"<NAME>"			Shows the current PRESET name
	DEVICE_NAME	"<NAME>"			Shows the Device Name
	INFO_MODEL	<Device Model>			Shows the Device Model
	INFO_VERSION	<Firmware Version>			Shows the Firmware Version
	INFO_MAC	<Device MAC address>			Shows the Device MAC address
	INFO_IPLIST	<N>	<IP>	<PORT>	Shows the IP parameters of the connected client devices, where N is an incremental number assigned to each one, followed by the IP:port it has Example with 2 clients : DATA INFO_IPLIST 1 192.168.1.2 55229 DATA INFO_IPLIST 2 192.168.1.2 55231

IP_CONFIG	IP>	<PORT>	<NETMASK>	<GATEWAY>	Shows the DUO-NET unit's current IP configuration. Example: <i>DATA IP_CONFIG</i> <i>192.168.0.6 5000</i> <i>255.255.0.0 192.168.0.1</i>
PLAYER_NAME	<PLAYER:A/B>	"<NAME>"			Shows the PLAYER A or B NAME
PLAYER_MUTE	<PLAYER:A/B>	<MUTE:YES/NO>			Shows the MUTE status of PLAYER A or B
PLAYER_VOLUME	<PLAYER:A/B>	<VOL:0..100>			Shows the VOLUME level of PLAYER A or B
PLAYER_VUMETER	<PLAYER:A/B>	<VOL:0..100>			Shows the VUMETER level of PLAYER A or B
PLAYER_TIME	<PLAYER:A/B>	<ELAPSED>	<REMAIN>	<TOTAL>	Shows PLAYER A or B elapsed, remaining and total time of the current media playback
PLAYER_TRANSPORT_STATUS	<PLAYER:A/B>	<STATUS:STOPPED/PLAYING/PAUSE>			Shows PLAYER A or B current playback status
PLAYER_PLAYLIST_INDEX	<PLAYER:A/B>	<INDEX:1..99>			Shows PLAYER A or B loaded playlist number, from the 99 available in the playlist bank
PLAYER_PLAYLIST_NAME	<PLAYER:A/B>	"<NAME>"			Shows PLAYER A or B loaded playlist name, from the 99 available in the playlist bank

PLAYER_QUEUE_INFO	<PLAYER:A/B>	<QUEUE_INDEX>	<QUEUE_COUNT>	Shows PLAYER A or B current playback queue position (index) and total number of items in it (count)
PLAYER_PLAY_MODE	<PLAYER:A/B>	<MODE:SEQUENTIAL/RANDOM>		Shows PLAYER A or B current playback order mode
PLAYER_REPEAT_MODE	<PLAYER:A/B>	<MODE:PLAY_ALL/PLAY_ONE/REPEAT_ALL/REPEAT_ONE>		Shows PLAYER A or B current playback repeat mode
PLAYER_FADE_MODE	<PLAYER:A/B>	<MODE:NONE/XFADE/FADE/HFADE>		Shows PLAYER A or B current tracks playback transition mode
PLAYER_VARISPEED	<PLAYER:A/B>	<VALUE:-50..50>		Shows PLAYER A or B current playback tempo variation value
PRIORITY_STATUS	<PRIORITY:1/2>	<STATUS:RUNNING/STOPPED>		Shows PRIORITY MODULE 1 or 2 status
PLAYER_ITEM_TAG_ALIAS	<PLAYER:A/B>	"<ALIAS>"		Shows PLAYER A or B current playlist ALIAS field
PLAYER_ITEM_TAG_TITLE	<PLAYER:A/B>	"<TITLE>"		Shows PLAYER A or B current playback title tag
PLAYER_ITEM_TAG_ARTIST	<PLAYER:A/B>	"<ARTIST>"		Shows PLAYER A or B current playback artist tag
PLAYER_ITEM_TAG_ALBUM	<PLAYER:A/B>	"<ALBUM>"		Shows PLAYER A or B current playback album tag
PLAYER_ITEM_TAG_NAME	<PLAYER:A/B>	"<NAME>"		Shows PLAYER A or B current playback name tag

20 ERROR CODES FOR ECLERNET DEVICES

20.1 COMMON ERROR CODES (to all EclerNet - TP-NET compatible devices)

ERROR ID	DESCRIPTION
0	TPNET_ERROR_NONE = 0,
1	TPNET_ERROR_INVALID_FIELD_TYPE,
2	TPNET_ERROR_INVALID_FIELD_PARAM1,
3	TPNET_ERROR_INVALID_FIELD_PARAM2,
4	TPNET_ERROR_INVALID_FIELD_PARAM3,
5	TPNET_ERROR_INVALID_FIELD_PARAM4,

20.2 NXA SERIES SPECIFIC ERROR CODES

ERROR ID	DESCRIPTION
6	UDP_ERROR_TIMEOUT_PONG,
7	UDP_ERROR_CONNECT_WHILE_CONNECTED,
8	UDP_ERROR_DISCONNECT_WHILE_UNCONNECTED,
9	UDP_ERROR_INVALID_CLIENT_IP,
10	UDP_ERROR_MESSAGE_TOO_LONG,
11	UDP_ERROR_UNSUPPORTED_MESSAGE,
12	UDP_ERROR_UNSUPPORTED_PRESET_NUMBER,
13	UDP_ERROR_UNSUPPORTED_INPUT_CHANNEL_NUMBER,
14	UDP_ERROR_UNSUPPORTED_OUTPUT_CHANNEL_NUMBER,
15	UDP_ERROR_UNSUPPORTED_GPI_NUMBER,
16	UDP_ERROR_UNSUPPORTED_GPO_NUMBER,
17	UDP_ERROR_INVALID_LEVEL_VALUE,
18	UDP_ERROR_INVALID_RATE_VALUE,
19	UDP_ERROR_GPO_VALUE,
20	UDP_ERROR_MAX_CLIENTS_REACHED,
21	UDP_ERROR_MASTER_MODE,

20.3 NZA SERIES SPECIFIC ERROR CODES

ERROR ID	DESCRIPTION
6	UDP_ERROR_TIMEOUT_PONG,
7	UDP_ERROR_CONNECT_WHILE_CONNECTED,
8	UDP_ERROR_DISCONNECT_WHILE_UNCONNECTED,
9	UDP_ERROR_INVALID_CLIENT_IP,
10	UDP_ERROR_MESSAGE_TOO_LONG,
11	UDP_ERROR_UNSUPPORTED_MESSAGE,
12	UDP_ERROR_UNSUPPORTED_PRESET_NUMBER,
13	UDP_ERROR_UNSUPPORTED_INPUT_CHANNEL_NUMBER,
14	UDP_ERROR_UNSUPPORTED_OUTPUT_CHANNEL_NUMBER,
15	UDP_ERROR_UNSUPPORTED_GPI_NUMBER,
16	UDP_ERROR_UNSUPPORTED_GPO_NUMBER,
17	UDP_ERROR_INVALID_LEVEL_VALUE,
18	UDP_ERROR_INVALID_RATE_VALUE,
19	UDP_ERROR_GPO_VALUE,
20	UDP_ERROR_UNSUPPORTED_INPUT_SELECT_VALUE,

20.4 NPA, MIMO7272DN, MIMO4040CDN, MIMO88 & MIMO88 CONFERENCE SERIES SPECIFIC ERROR CODES

ERROR ID	DESCRIPTION
6	UDP_ERROR_TIMEOUT_PONG,
7	UDP_ERROR_CONNECT_WHILE_CONNECTED,
8	UDP_ERROR_DISCONNECT_WHILE_UNCONNECTED,
9	UDP_ERROR_INVALID_CLIENT_IP,
10	UDP_ERROR_MESSAGE_TOO_LONG,
11	UDP_ERROR_UNSUPPORTED_MESSAGE,
12	UDP_ERROR_UNSUPPORTED_PRESET_NUMBER,
13	UDP_ERROR_UNSUPPORTED_INPUT_CHANNEL_NUMBER,
14	UDP_ERROR_UNSUPPORTED_OUTPUT_CHANNEL_NUMBER,
15	UDP_ERROR_UNSUPPORTED_GPI_NUMBER,
16	UDP_ERROR_UNSUPPORTED_GPO_NUMBER,
17	UDP_ERROR_INVALID_LEVEL_VALUE,
18	UDP_ERROR_INVALID_RATE_VALUE,
19	UDP_ERROR_GPO_VALUE,

20.5 MIMO88SG, MIMO1212SG, MIMO88SG CONFERENCE & MIMO1212SG CONFERENCE SERIES SPECIFIC ERROR CODES

ERROR ID	DESCRIPTION
6	UDP_ERROR_TIMEOUT_PONG,
7	UDP_ERROR_CONNECT_WHILE_CONNECTED,
8	UDP_ERROR_DISCONNECT_WHILE_UNCONNECTED,
9	UDP_ERROR_INVALID_CLIENT_IP,
10	UDP_ERROR_MESSAGE_TOO_LONG,
11	UDP_ERROR_UNSUPPORTED_MESSAGE,
12	UDP_ERROR_UNSUPPORTED_PRESET_NUMBER,
13	UDP_ERROR_UNSUPPORTED_INPUT_CHANNEL_NUMBER,
14	UDP_ERROR_UNSUPPORTED_OUTPUT_CHANNEL_NUMBER,
15	UDP_ERROR_UNSUPPORTED_GPI_NUMBER,
16	UDP_ERROR_INVALID_LEVEL_VALUE,
17	UDP_ERROR_INVALID_RATE_VALUE,

20.6 DUO-NET PLAYER SPECIFIC ERROR CODES

ERROR ID	DESCRIPTION
6	TPNET_ERROR_INVALID_FIELD_PARAM5,
7	TPNET_ERROR_TIMEOUT_PONG,
8	TPNET_ERROR_CONNECT_WHILE_CONNECTED,
9	TPNET_ERROR_DISCONNECT_WHILE_UNCONNECTED,
10	TPNET_ERROR_INVALID_CLIENT_IP,
11	TPNET_ERROR_MESSAGE_TOO_LONG,
12	TPNET_ERROR_UNSUPPORTED_MESSAGE,
13	TPNET_ERROR_INVALID_RATE_VALUE,
14	TPNET_ERROR_MAX_CLIENTS_REACHED,
15	TPNET_ERROR_MASTER_MODE,

21 eMIMO1616 DIGITAL MATRIX

IMPORTANT NOTE: The communication must be started with the client sending **the first message SYSTEM CONNECT** to the device. Otherwise, the commands from the client to the EclerNet device will be ignored. See [TP-NET PROTOCOL INTRODUCTION](#) chapter for additional information.

TYPE	PARAM1	PARAM2	PARAM3	PARAM4	DESCRIPTION
SYSTEM	CONNECT	[PINGPONG]			Saves the client IP address for responses and then dumps current device status (with DATA messages)
	DISCONNECT				Cancel subscriptions and terminates communication
	SUBSCRIPTION_RATE	<Rate>			Alive message from device
	PING_INTERVAL	<1-1000>			Ping Interval, in seconds
	PING				Alive message from device
	PONG				Alive ACK message from client
GET	ALL				Dumps current device status (with DATA messages)
	INFO_NAME				Gets the Device Name
	INFO_MODEL				Gets the Device Model
	INFO_VERSION				Gets the Firmware Version
	INFO_MAC				Gets the Device MAC address
	IP_CONFIG				Gets the Device network configuration
	INFO_IPLIST				Gets the list of clients connected to the Device
	INAME	<Input Channel>			Gets the NAME (label) of an Input Channel
	ILEVEL	<Input Channel>			Gets the current LEVEL of an Input Channel
	IMUTE	<Input Channel>			Gets the current MUTE status of an Input Channel
IBASSGAIN	<Input Channel>			Gets the current BASS EQ filter GAIN of an Input Channel	

	IMIDGAIN	<Input Channel>			Gets the current MID EQ filter GAIN of an Input Channel
	ITREBLEGAIN	<Input Channel>			Gets the current TREBLE EQ filter GAIN of an Input Channel
	IVU	<Input Channel>			Gets the VU-meter value of an Input Channel
	ONAME	<Output Channel>			Gets the NAME (label) of an Output Channel
	OLEVEL	<Output Channel>			Gets the current LEVEL of an Output Channel
	OMUTE	<Output Channel>			Gets the current MUTE status of an Output Channel
	OBASSGAIN	<Output Channel>			Gets the current BASS EQ filter GAIN of an Output Channel
	OMIDGAIN	<Output Channel>			Gets the current MID EQ filter GAIN of an Output Channel
	OTREBLEGAIN	<Output Channel>			Gets the current TREBLE EQ filter GAIN of an Output Channel
	OVU	<Output Channel>			Gets the VU-meter value of an Output Channel
	OSOURCESEL	<Output Channel>			Gets the current selected source (input) of an Output Channel

TYPE	PARAM1	PARAM2	PARAM3	PARAM4	DESCRIPTION
SET	IMUTE	<Input Channel>	YES/NO		Sets the current MUTE status of an Input Channel
	ILEVEL	<Input Channel>	<Level>		Sets the current LEVEL of an Input Channel (Level can range from 1 to 100)
	IBASSGAIN	<Input Channel>	<Gain>		Sets the current BASS EQ filter GAIN of an Input Channel (Gain can range from ± 1 to ± 100)
	IMIDGAIN	<Input Channel>	<Gain>		Sets the current MID EQ filter GAIN of an Input Channel (Gain can range from ± 1 to ± 100)
	ITREBLEGAIN	<Input Channel>	<Gain>		Sets the current TREBLE EQ filter GAIN of an Input Channel (Gain can range from ± 1 to ± 100)
	OMUTE	<Output Channel>	YES/NO		Sets the current MUTE status of an Output Channel
	OLEVEL	<Output Channel>	<Level>		Sets the current LEVEL of an Output Channel (Level can range from 1 to 100)
	OBASSGAIN	<Output Channel>	<Gain>		Sets the current BASS EQ filter GAIN of an Output Channel (Gain can range from ± 1 to ± 100)
	OMIDGAIN	<Output Channel>	<Gain>		Sets the current MID EQ filter GAIN of an Output Channel (Gain can range from ± 1 to ± 100)
	OTREBLEGAIN	<Output Channel>	<Gain>		Sets the current TREBLE EQ filter GAIN of an Output Channel (Gain can range from ± 1 to ± 100)
	OSOURCESEL	<Output Channel>	<Input>		Sets the selected source (input) for an Output Channel (Input (source) can range from 0 to 16, meaning 0 = no source (silence))
INC	ILEVEL	<Input Channel >	<Value>		Increases the current LEVEL of an Input Channel by Value (Value can range from ± 1 to ± 100)
	IBASSGAIN	<Input Channel>	<Value>		Increases the current BASS EQ filter GAIN of an Input Channel by Value (Value can range from ± 1 to ± 200 , where 200 means 20.0 -> values are steps like nn.n, with decimal fraction)

	IMIDGAIN	<Input Channel>	<Value>		Increases the current MID EQ filter GAIN of an Input Channel by Value (Value can range from ± 1 to ± 200 , where 200 means 20.0 -> values are steps like nn.n, with decimal fraction)
	ITREBLEGAIN	<Input Channel>	<Value>		Increases the current TREBLE EQ filter GAIN of an Input Channel by Value (Value can range from ± 1 to ± 200 , where 200 means 20.0 -> values are steps like nn.n, with decimal fraction)
	OLEVEL	<Output Channel>	<Value>		Increases the current LEVEL of an Output Channel by Value (Value can range from ± 1 to ± 100)
	OBASSGAIN	<Input Channel>	<Value>		Increases the current BASS EQ filter GAIN of an Output Channel by Value (Value can range from ± 1 to ± 200 , where 200 means 20.0 -> values are steps like nn.n, with decimal fraction)
	OMIDGAIN	<Input Channel>	<Value>		Increases the current MID EQ filter GAIN of an Output Channel by Value (Value can range from ± 1 to ± 200 , where 200 means 20.0 -> values are steps like nn.n, with decimal fraction)
	OTREBLEGAIN	<Input Channel>	<Value>		Increases the current TREBLE EQ filter GAIN of an Output Channel by Value (Value can range from ± 1 to ± 200 , where 200 means 20.0 -> values are steps like nn.n, with decimal fraction)
DEC	ILEVEL	<Input Channel >	<Value>		Decreases the current LEVEL of an Input Channel by Value (Value can range from ± 1 to ± 100)
	IBASSGAIN	<Input Channel>	<Value>		Decreases the current BASS EQ filter GAIN of an Input Channel by Value (Value can range from ± 1 to ± 200 , where 200 means 20.0 -> values are steps like nn.n, with decimal fraction)
	IMIDGAIN	<Input Channel>	<Value>		Decreases the current MID EQ filter GAIN of an Input Channel by Value (Value can range from ± 1 to ± 200 , where 200 means 20.0 -> values are steps like nn.n, with decimal fraction)

	ITREBLEGAIN	<Input Channel>	<Value>		Decreases the current TREBLE EQ filter GAIN of an Input Channel by Value (Value can range from ± 1 to ± 200 , where 200 means 20.0 -> values are steps like nn.n, with decimal fraction)
	OLEVEL	<Output Channel>	<Value>		Decreases the current LEVEL of an Output Channel by Value (Value can range from ± 1 to ± 100)
	OBASSGAIN	<Input Channel>	<Value>		Decreases the current BASS EQ filter GAIN of an Output Channel by Value (Value can range from ± 1 to ± 200 , where 200 means 20.0 -> values are steps like nn.n, with decimal fraction)
	OMIDGAIN	<Input Channel>	<Value>		Decreases the current MID EQ filter GAIN of an Output Channel by Value (Value can range from ± 1 to ± 200 , where 200 means 20.0 -> values are steps like nn.n, with decimal fraction)
	OTREBLEGAIN	<Input Channel>	<Value>		Decreases the current TREBLE EQ filter GAIN of an Output Channel by Value (Value can range from ± 1 to ± 200 , where 200 means 20.0 -> values are steps like nn.n, with decimal fraction)
SUBSCRIBE	ALL				Subscribes to all VU-meters
	IVU	<Input Channel>			Subscribes to an Input Channel VU-meter
	OVU	<Output Channel>			Subscribes to an Output Channel VU-meter
UNSUBSCRIBE	ALL				Unsubscribe to all VU-meters
	IVU	<Input Channel>			Unsubscribe to an Input Channel VU-meter
	OVU	<Output Channel>			Unsubscribe to an Output Channel VU-meter

Note: **INC** and **DEC** commands are replied with a **DATA** command from the device with the resulting LEVEL value, after it has been increased or decreased. When the **INC** or **DEC** command tries to adjust a LEVEL value beyond its minimum or maximum limits, no reply (**DATA** command) will be produced.

TYPE	PARAM1	PARAM2	PARAM3	PARAM4	DESCRIPTION
DATA	INFO_NAME	"<Device Name>"			Shows the Device Name
	INFO_MODEL	<Device Model>			Shows the Device Model
	INFO_VERSION	<Firmware Version>			Shows the Firmware Version
	INFO_MAC	<Device MAC address>			Shows the Device MAC address
	IP_CONFIG				Shows the Device network configuration. The message will contain DeviceIP DeviceMask DeviceGateway (separated by blank characters)
	INFO_IPLIST				Shows the list of clients connected to the Device. The message will contain a list including ClientNumber ClientIP Client Port (separated by blank characters)
	INAME	<Input Channel>	<Name>		Shows the NAME (label) of an Input Channel
	ILEVEL	<Input Channel>	<Level>		Shows the current LEVEL of an Input Channel
	IMUTE	<Input Channel>	YES/NO		Shows the current MUTE status of an Input Channel
	IBASSGAIN	<Input Channel>	<Gain>		Shows the current BASS EQ filter GAIN of an Input Channel
	IMIDGAIN	<Input Channel>	<Gain>		Shows the current MID EQ filter GAIN of an Input Channel
	ITREBLEGAIN	<Input Channel>	<Gain>		Shows the current TREBLE EQ filter GAIN of an Input Channel
	IVU	<Input Channel>	<Post Vumeter Level>		Shows the VU-meter value of an Input Channel
	ONAME	<Output Channel>	<Name>		Shows the NAME (label) of an Output Channel
OLEVEL	<Output Channel>	<Level>		Shows the current LEVEL of an Output Channel	

	OMUTE	<Output Channel>	YES/NO		Shows the current MUTE status of an Output Channel
	OBASSGAIN	<Input Channel>	<Gain>		Shows the current BASS EQ filter GAIN of an Output Channel
	OMIDGAIN	<Input Channel>	<Gain>		Shows the current MID EQ filter GAIN of an Output Channel
	OTREBLEGAIN	<Input Channel>	<Gain>		Shows the current TREBLE EQ filter GAIN of an Output Channel
	OVU	<Output Channel>	<Post Vumeter Level>		Shows the VU-meter value of an Output Channel
	OSOURCESEL	<Output Channel>	<Input>		Shows the current selected source (input) of an Output Channel. (Input (source) can range from 0 to 16, meaning 0 = no source (silence))
ERROR	<Error ID>	"<Error Description>"			Informs about an error

22 eMIMO1616 ERROR CODES

ERROR ID	DESCRIPTION
0	No error. Depending on scenario, can report any of the following: <ul style="list-style-type: none"> • Device is in TEST MODE • Device is in FACTORY MODE • Last loaded project was incomplete • Now Disconnected
1	Invalid Field MSG
2	Depending on scenario, can report any of the following: <ul style="list-style-type: none"> • Invalid Field DATA • Invalid Field VALUE • Invalid Field PARAM1
3	Invalid Field CHANNEL
4	Invalid Field VALUE
7	Timeout Waiting PONG
8	CONNECT received while connected
9	DISCONNECT received while unconnected
10	Invalid client (client not connected)
11	Message too long (more than 80 characters)
12	Message with invalid format
13	Depending on scenario, can report any of the following: <ul style="list-style-type: none"> • Invalid Ping Interval value • Invalid Subscription Interval value
14	Maximum number of clients reached
15	Master Mode active

23 HUB SERIES DIGITAL ZONER

IMPORTANT NOTE: The communication must be started with the client sending **the first message SYSTEM CONNECT** to the device. Otherwise, the commands from the client to the EclerNet device will be ignored. See [TP-NET PROTOCOL INTRODUCTION](#) chapter for additional information.

TYPE	PARAM1	PARAM2	PARAM3	PARAM4	DESCRIPTION
SYSTEM	CONNECT	[PINGPONG]			Saves the client IP address for responses and then dumps current device status (with DATA messages)
	DISCONNECT				Cancel subscriptions and terminates communication
	SUBSCRIPTION_RATE	<Rate>			Alive message from device
	PING_INTERVAL	<1-1000>			Ping Interval, in seconds
	PING				Alive message from device
	PONG				Alive ACK message from client
GET	ALL				Dumps current device status (with DATA messages)
	INFO_NAME				Gets the Device Name
	INFO_MODEL				Gets the Device Model
	INFO_VERSION				Gets the Firmware Version
	INFO_MAC				Gets the Device MAC address
	IP_CONFIG				Gets the Device network configuration
	INFO_IPLIST				Gets the list of clients connected to the Device
	INAME	<Input Channel>			Gets the NAME (label) of an Input Channel
	ILEVEL	<Input Channel>			Gets the current LEVEL of an Input Channel
	IMUTE	<Input Channel>			Gets the current MUTE status of an Input Channel
IBASSGAIN	<Input Channel>			Gets the current BASS EQ filter GAIN of an Input Channel	

	IMIDGAIN	<Input Channel>			Gets the current MID EQ filter GAIN of an Input Channel
	ITREBLEGAIN	<Input Channel>			Gets the current TREBLE EQ filter GAIN of an Input Channel
	IVU	<Input Channel>			Gets the VU-meter value of an Input Channel
	ONAME	<Output Channel>			Gets the NAME (label) of an Output Channel
	OLEVEL	<Output Channel>			Gets the current LEVEL of an Output Channel
	OMUTE	<Output Channel>			Gets the current MUTE status of an Output Channel
	OGENVOL				Gets the current LEVEL of the General Volume
	OMUTEGENVOL				Gets the current MUTE status of the General Volume
	OBASSGAIN	<Output Channel>			Gets the current BASS EQ filter GAIN of an Output Channel
	OMIDGAIN	<Output Channel>			Gets the current MID EQ filter GAIN of an Output Channel
	OTREBLEGAIN	<Output Channel>			Gets the current TREBLE EQ filter GAIN of an Output Channel
	OVU	<Output Channel>			Gets the VU-meter value of an Output Channel
	OSOURCESEL	<Output Channel>			Gets the current selected source (input) of an Output Channel

TYPE	PARAM1	PARAM2	PARAM3	PARAM4	DESCRIPTION
SET	IMUTE	<Input Channel>	YES/NO		Sets the current MUTE status of an Input Channel
	ILEVEL	<Input Channel>	<Level>		Sets the current LEVEL of an Input Channel (Level can range from 1 to 100)
	IBASSGAIN	<Input Channel>	<Gain>		Sets the current BASS EQ filter GAIN of an Input Channel (Gain can range from ± 1 to ± 100)
	IMIDGAIN	<Input Channel>	<Gain>		Sets the current MID EQ filter GAIN of an Input Channel (Gain can range from ± 1 to ± 100)

	ITREBLEGAIN	<Input Channel>	<Gain>		Sets the current TREBLE EQ filter GAIN of an Input Channel (Gain can range from ± 1 to ± 100)
	OMUTE	<Output Channel>	YES/NO		Sets the current MUTE status of an Output Channel
	OLEVEL	<Output Channel>	<Level>		Sets the current LEVEL of an Output Channel (Level can range from 1 to 100)
	OGENVOL	<Level>			Sets the current LEVEL of the General Volume (Level can range from 1 to 100)
	OMUTEGENVOL	YES/NO			Sets the current MUTE status of the General Volume
	OBASSGAIN	<Output Channel>	<Gain>		Sets the current BASS EQ filter GAIN of an Output Channel (Gain can range from ± 1 to ± 100)
	OMIDGAIN	<Output Channel>	<Gain>		Sets the current MID EQ filter GAIN of an Output Channel (Gain can range from ± 1 to ± 100)
	OTREBLEGAIN	<Output Channel>	<Gain>		Sets the current TREBLE EQ filter GAIN of an Output Channel (Gain can range from ± 1 to ± 100)
	OSOURCESEL	<Output Channel>	<Input>		Sets the selected source (input) for an Output Channel (Input (source) can range from 0 to 16, meaning 0 = no source (silence))
INC	ILEVEL	<Input Channel >	<Value>		Increases the current LEVEL of an Input Channel by Value (Value can range from ± 1 to ± 100)
	IBASSGAIN	<Input Channel>	<Value>		Increases the current BASS EQ filter GAIN of an Input Channel by Value (Value can range from ± 1 to ± 200 , where 200 means 20.0 -> values are steps like nn.n, with decimal fraction)
	IMIDGAIN	<Input Channel>	<Value>		Increases the current MID EQ filter GAIN of an Input Channel by Value (Value can range from ± 1 to ± 200 , where 200 means 20.0 -> values are steps like nn.n, with decimal fraction)

	ITREBLEGAIN	<Input Channel>	<Value>		Increases the current TREBLE EQ filter GAIN of an Input Channel by Value (Value can range from ± 1 to ± 200 , where 200 means 20.0 -> values are steps like nn.n, with decimal fraction)
	OLEVEL	<Output Channel>	<Value>		Increases the current LEVEL of an Output Channel by Value (Value can range from ± 1 to ± 100)
	OGENVOL	<Value>			Increases the current LEVEL of the General Volume by Value (Value can range from ± 1 to ± 100)
	OBASSGAIN	<Input Channel>	<Value>		Increases the current BASS EQ filter GAIN of an Output Channel by Value (Value can range from ± 1 to ± 200 , where 200 means 20.0 -> values are steps like nn.n, with decimal fraction)
	OMIDGAIN	<Input Channel>	<Value>		Increases the current MID EQ filter GAIN of an Output Channel by Value (Value can range from ± 1 to ± 200 , where 200 means 20.0 -> values are steps like nn.n, with decimal fraction)
	OTREBLEGAIN	<Input Channel>	<Value>		Increases the current TREBLE EQ filter GAIN of an Output Channel by Value (Value can range from ± 1 to ± 200 , where 200 means 20.0 -> values are steps like nn.n, with decimal fraction)
DEC	ILEVEL	<Input Channel >	<Value>		Decreases the current LEVEL of an Input Channel by Value (Value can range from ± 1 to ± 100)
	IBASSGAIN	<Input Channel>	<Value>		Decreases the current BASS EQ filter GAIN of an Input Channel by Value (Value can range from ± 1 to ± 200 , where 200 means 20.0 -> values are steps like nn.n, with decimal fraction)
	IMIDGAIN	<Input Channel>	<Value>		Decreases the current MID EQ filter GAIN of an Input Channel by Value (Value can range from ± 1 to ± 200 , where 200 means 20.0 -> values are steps like nn.n, with decimal fraction)

	ITREBLEGAIN	<Input Channel>	<Value>		Decreases the current TREBLE EQ filter GAIN of an Input Channel by Value (Value can range from ± 1 to ± 200 , where 200 means 20.0 -> values are steps like nn.n, with decimal fraction)
	OLEVEL	<Output Channel>	<Value>		Decreases the current LEVEL of an Output Channel by Value (Value can range from ± 1 to ± 100)
	OGENVOL	<Value>			Decreases the current LEVEL of the General Volume by Value (Value can range from ± 1 to ± 100)
	OBASSGAIN	<Input Channel>	<Value>		Decreases the current BASS EQ filter GAIN of an Output Channel by Value (Value can range from ± 1 to ± 200 , where 200 means 20.0 -> values are steps like nn.n, with decimal fraction)
	OMIDGAIN	<Input Channel>	<Value>		Decreases the current MID EQ filter GAIN of an Output Channel by Value (Value can range from ± 1 to ± 200 , where 200 means 20.0 -> values are steps like nn.n, with decimal fraction)
	OTREBLEGAIN	<Input Channel>	<Value>		Decreases the current TREBLE EQ filter GAIN of an Output Channel by Value (Value can range from ± 1 to ± 200 , where 200 means 20.0 -> values are steps like nn.n, with decimal fraction)
SUBSCRIBE	ALL				Subscribes to all VU-meters
	IVU	<Input Channel>			Subscribes to an Input Channel VU-meter
	OVU	<Output Channel>			Subscribes to an Output Channel VU-meter
UNSUBSCRIBE	ALL				Unsubscribe to all VU-meters
	IVU	<Input Channel>			Unsubscribe to an Input Channel VU-meter
	OVU	<Output Channel>			Unsubscribe to an Output Channel VU-meter

Note: **INC** and **DEC** commands are replied with a **DATA** command from the device with the resulting LEVEL value, after it has been increased or decreased. When the **INC** or **DEC** command tries to adjust a LEVEL value beyond its minimum or maximum limits, no reply (**DATA** command) will be produced.

TYPE	PARAM1	PARAM2	PARAM3	PARAM4	DESCRIPTION
DATA	INFO_NAME	"<Device Name>"			Shows the Device Name
	INFO_MODEL	<Device Model>			Shows the Device Model
	INFO_VERSION	<Firmware Version>			Shows the Firmware Version
	INFO_MAC	<Device MAC address>			Shows the Device MAC address
	IP_CONFIG				Shows the Device network configuration. The message will contain DeviceIP DeviceMask DeviceGateway (separated by blank characters)
	INFO_IPLIST				Shows the list of clients connected to the Device. The message will contain a list including ClientNumber ClientIP Client Port (separated by blank characters)
	INAME	<Input Channel>	<Name>		Shows the NAME (label) of an Input Channel
	ILEVEL	<Input Channel>	<Level>		Shows the current LEVEL of an Input Channel
	IMUTE	<Input Channel>	YES/NO		Shows the current MUTE status of an Input Channel
	IBASSGAIN	<Input Channel>	<Gain>		Shows the current BASS EQ filter GAIN of an Input Channel
	IMIDGAIN	<Input Channel>	<Gain>		Shows the current MID EQ filter GAIN of an Input Channel
	ITREBLEGAIN	<Input Channel>	<Gain>		Shows the current TREBLE EQ filter GAIN of an Input Channel
	IVU	<Input Channel>	<Post Vumeter Level>		Shows the VU-meter value of an Input Channel
	ONAME	<Output Channel>	<Name>		Shows the NAME (label) of an Output Channel
OLEVEL	<Output Channel>	<Level>		Shows the current LEVEL of an Output Channel	

	OMUTE	<Output Channel>	YES/NO		Shows the current MUTE status of an Output Channel
	OGENVOL	<Level>			Shows the current LEVEL of the General Volume
	OMUTEGENVOL	YES/NO			Shows the current MUTE status of the General Volume
	OBASSGAIN	<Input Channel>	<Gain>		Shows the current BASS EQ filter GAIN of an Output Channel
	OMIDGAIN	<Input Channel>	<Gain>		Shows the current MID EQ filter GAIN of an Output Channel
	OTREBLEGAIN	<Input Channel>	<Gain>		Shows the current TREBLE EQ filter GAIN of an Output Channel
	OVU	<Output Channel>	<Post Vumeter Level>		Shows the VU-meter value of an Output Channel
	OSOURCESEL	<Output Channel>	<Input>		Shows the current selected source (input) of an Output Channel. (Input (source) can range from 0 to 16, meaning 0 = no source (silence))
ERROR	<Error ID>	"<Error Description>"			Informs about an error

24 HUB SERIES ERROR CODES

ERROR ID	DESCRIPTION
0	No error. Depending on scenario, can report any of the following: <ul style="list-style-type: none"> • Device is in TEST MODE • Device is in FACTORY MODE • Last loaded project was incomplete • Now Disconnected
1	Invalid Field MSG
2	Depending on scenario, can report any of the following: <ul style="list-style-type: none"> • Invalid Field DATA • Invalid Field VALUE • Invalid Field PARAM1
3	Invalid Field CHANNEL
4	Invalid Field VALUE
7	Timeout Waiting PONG
8	CONNECT received while connected
9	DISCONNECT received while unconnected
10	Invalid client (client not connected)
11	Message too long (more than 80 characters)
12	Message with invalid format
13	Depending on scenario, can report any of the following: <ul style="list-style-type: none"> • Invalid Ping Interval value • Invalid Subscription Interval value
14	Maximum number of clients reached
15	Master Mode active

