

WARM2

DJ Mixer

Two-Channel Analogue Rotary Mixer



USER MANUAL

INDEX

1. IMPORTANT REMARK.....	4
2. IMPORTANT SAFETY INSTRUCTIONS.....	4
3. IMPORTANT NOTE.....	7
4. WARM2 and ECLER HISTORY.....	7
5. INTRODUCTION.....	9
Key Features.....	9
6. FUNCTION DIAGRAM.....	10
7. INSTALLATION AND CONNECTION.....	11
<i>Audio Input Connections.....</i>	<i>11</i>
Phono Inputs.....	12
Line Inputs.....	12
Microphone Input.....	12
<i>Audio Output Connections.....</i>	<i>13</i>
HOUSE Output.....	13
BOOTH Output.....	13
Record output.....	13
FX Send/Return effects loop.....	14
Headphones.....	14
8. QUICK START.....	15
9. OPERATION AND USAGE.....	17
<i>Start-up.....</i>	<i>17</i>
<i>Control Description.....</i>	<i>17</i>
Input selector.....	17
Channel TRIM.....	17
Equalization.....	18
Monitoring System.....	18
Sending to external effects units FX Send/Return.....	18
Potentiometers.....	19
HOUSE and BOOTH output levels.....	19

10. FURTHER CONSIDERATIONS.....	20
<i>Ground loops</i>	20
<i>Background noise</i>	20
<i>Audio connections</i>	20
<i>Cleaning</i>	20
11. CONFIGURATION DIAGRAM	21
12. BLOCKS DIAGRAM	22
13. TECHNICAL FEATURES	23
14. ECLER SIGNATURE.....	25

1. IMPORTANT REMARK



WARNING: SHOCK HAZARD - DO NOT OPEN

AVIS: RISQUE DE CHOC ÉLECTRIQUE - NE PAS OUVRIR



The lightning flash with arrowhead symbol, within an equilateral triangle, is intended to alert the user to the presence of uninsulated “dangerous voltage” within the product’s enclosure that may be of sufficient magnitude to constitute a risk of electric shock to persons.



The exclamation point within an equilateral triangle is intended to alert the user to the presence of important operating and maintenance (servicing) instructions in the literature accompanying the appliance.

WARNING (If applicable): The terminals marked with symbol of “” may be of sufficient magnitude to constitute a risk of electric shock. The external wiring connected to the terminals requires installation by an instructed person or the use of ready-made leads or cords.

WARNING: To prevent fire or shock hazard, do not expose this equipment to rain or moisture.

WARNING: An apparatus with Class I construction shall be connected to a mains socket-outlet with a protective earthing connection.

2. IMPORTANT SAFETY INSTRUCTIONS

1. Read these instructions.
2. Keep these instructions.
3. Heed all warnings.

4. Follow all instructions.
5. Do not use this apparatus near water.
6. Clean only with dry cloth.
7. Do not block any ventilation openings. Install in accordance with the manufacturer's instructions.
8. Do not install near any heat sources such as radiators, heat registers, stoves, or other apparatus (including amplifiers) that produce heat.
9. Do not defeat the safety purpose of the polarized or grounding type plug. A polarized plug has two blades with one wider than the other. A grounding type plug has two blades and a third grounding prong. The wide blade or the third prong are provided for your safety. If the provided plug does not fit into your outlet, consult an electrician for replacement of the obsolete outlet.
10. Protect the power cord from being walked on or pinched particularly at the plugs, convenience receptacles, and at the point where they exit from the apparatus.
11. Only use attachments/accessories specified by the manufacturer.
12. Unplug the apparatus during lightning sorts or when unused for long periods of time.
13. Refer all servicing to qualified personnel. Servicing is required when the apparatus has been damaged in any way, such as power supply cord or plug is damaged, liquid has been spilled or objects have fallen into the apparatus, the apparatus has been exposed to rain or moisture, does not operate normally, or has been dropped.
14. Disconnecting from mains: Switching off the POWER switch all the functions and light indicators of the amplifier will be stopped, but fully disconnecting the device from mains is done unplugging the power cord from the mains input socket. For this reason, it always shall remain readily operable.
15. Equipment is connected to a socket-outlet with earthing connection by means of a power cord.
16. The marking information is located at the bottom of apparatus.

17. The apparatus shall not be exposed to dripping or splashing and that no objects filled with liquids, such as vases, shall be placed on apparatus.



WARNING: This product must not be discarded, under any circumstance, as unsorted urban waste. Take to the nearest electrical and electronic waste treatment centre.

NEEC AUDIO BARCELONA, S.L. accepts no liability for any damage that may be caused to people, animal or objects due to failure to comply with the warnings above.

3. IMPORTANT NOTE

Thank you for choosing our **WARM2 analogue rotary mixer**!

It is **VERY IMPORTANT** to carefully read this manual and to fully understand its contents before any connection in order to maximize your use and get the best performance from this equipment.

To ensure optimal operation of this device, we strongly recommend that its maintenance be carried out by our authorized Technical Services.

The Ecler **WARM2 analogue rotary mixer** come with a **3**-year warranty.

4. WARM2 and ECLER HISTORY

Although the origins of the company date from 1965, ECLER presented its first mixer back in the 70s: the A4, a simple 4 channel mixer oriented to Super 8 film sound edition. The company grew in the 70s with the boom of disco and tourism.

It was the era of the AM 4 and AC 4, the first mixers tailored to DJs. The AC 4 was a high fidelity mixer designed to meet the most demanding sound requirements in discos, theatres, cinemas, recording studios, conference rooms... The electronic circuits and the extreme selection of all components and transistors used, made the AC 4 a professional high quality mixer.

Milestones as SCLAT modular mixers, MAC Series High Standard Club mixers, AC-6 High-End Installation mixer ([recognize as a legendary mixer by Hispasonic](#)), the HAK Series battle mixers Designed and manufactured with expert consultation from DMC and ITF champions all over the world, or the award-winning Eternal contactless magnetic crossfader are Ecler constant innovation examples.

Ecler DJ Division Pro Team selected artists with a diverse and deep music background to share its inputs looking for the perfect mixing devices. From minimal to deep house, from techno to hip hop, from breaks to electro... all of them share our passion for music and technology. Dj's like Michael Mayer, Pastaboys, Luciano, Antoine Clamaran, Funk

D'Void, Dj Hell, Ricardo Villalobos, Savas Pascalidis (to name a few). When it comes to gear, they need the maximum quality, reliability and tools to express their creativity.

Ecler mixers was installed in prestigious clubs worldwide, such as Pacha (Marrakech) or Café del Mar (Ibiza).

After 13 years hiatus, Ecler release a new top notch mixer:

WARM2 Warehouse analogue rotary mixer!

WARM2 was inspired by The Warehouse in Chicago, a place where many consider the cradle of House Music back in 1977. This place ignited the spark that eventually became the House Music scene we love and admire today.

Back in the days, Frankie Knuckles, the godfather of House Music and The Warehouse first musical director, was reconstructing the soul and disco existing songs, by changing the tempo and layering different bits of percussion over them. These alterations transformed the dancefloor forever.

Rotary mixers have an special feel, creating a smoother and subtler transitions. Legendary Djs like Joe Clausell, Louie Vega and more recently Floating Points or Motorcity Drum Ensemble are top class users of these particular devices.

With WARM2, you'll be able to get Ecler's design expertise at your fingertips, its unquestionable audio quality, and the "Alps Blue Velvet" potentiometers precision for the perfect mix. The 4th order inbuilt isolator, will definitely expand your performance possibilities by removing frequencies, infusing drama in an acapella track, enhancing musical riffs or creating a tremolo effect by rapidly twisting the knobs.

With a width of 18.5 centimetres, WARM2 is the narrowest rotary mixer on the market. Despite this, it includes interesting features such as: 3-band EQ + Trim, FX Send control and Pre/Post fader selector, and an excellent dynamic and headroom range. WARM2 provides the best analogue sound for your dancefloor in a portable format.

5. INTRODUCTION

WARM2 is a professional two channels analogue rotary DJ mixer, designed and manufactured by ECLER in Barcelona. With over 50 years of experience in professional analogue audio design and using the best components available on the market, Ecler offers a new rotary mixer with a new best in class warm and crystal clear analogue sound, its classic sharp filters, a 4th order isolator and its narrow portable format. All circuits are strictly designed, mounted and tested at Ecler facilities in Barcelona, in order to offer the best professional grade quality and reliability.

Key Features

- 2+1 Mixing channels
 - 1 MICRO input
 - 2 PHONO inputs
 - 3 LINE inputs
 - Master Output (HOUSE) on XLR and RCA connectors
 - Booth Output on RCA connectors
 - 6.3mm Jack and 3.5mm mini-jack Headphone Monitor Outputs
 - 3 band full cut EQ for main channels and 2 band full cut EQ for MICRO/LINE channel
 - 3 bands isolator (300Hz and 4KHz, $-\infty/+12$ dB, 4th order 24dB/oct)
 - Maximum Output without distortion: 21dBV (23dBu)
 - Mechanized from a solid block of aluminum knob, without visible screw.
- Ecler Unique design
- Alps Blue Velvet Potentiometers
 - FX Send control and Pre/Post fader selector
 - Screen-printed faceplate by selective anodizing
 - Wooden side panels included

6. FUNCTION DIAGRAM

1. LED indicator ON
2. Input Selector (PHONO, LINE MIC)
3. Input sensitivity adjust, TRIM
4. Treble control, HIGH
5. Midrange control, MID
6. Bass control, BASS
7. Pre-Fader listening control, PFL
8. Send switch to effect bus, PRE/POST
9. Effect Send controller, FX SEND
10. Channel volume control
11. LED VU Meter
12. Isolator control
13. Channel 3 volume control
14. Master volume control, HOUSE
15. Monitoring volume control, BOOTH
16. Stereo Jack Headphones
17. Monitor Headphones Volume control
18. PFL/MIX monitoring control, SOURCE
19. RCA Monitoring Unbalanced Output, BOOTH
20. XLR Master Balanced Output, HOUSE
21. RCA Master Unbalanced Output, HOUSE
22. External FX return Input, FX RETURN
23. External FX send Output, FX SEND
24. Recording Output, REC
25. Line Input, LINE 2
26. Phono Input, PHONO 2
27. Line Input, LINE 3
28. Phono Ground Pin
29. Microphone Input, MICRO
30. Line Input, LINE 1
31. Phono Input, PHONO 1
32. Mains Socket
33. Power Switch

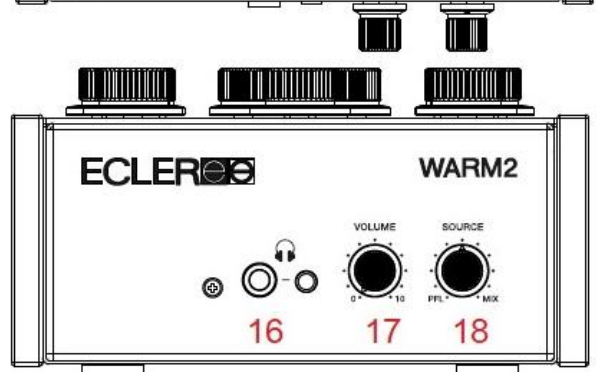
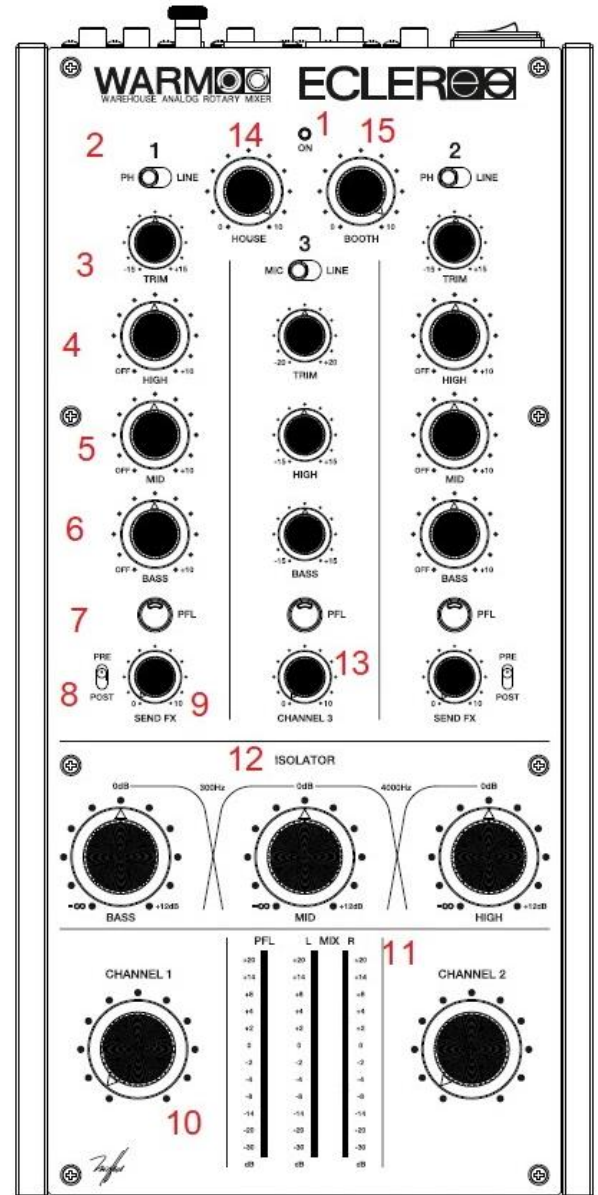
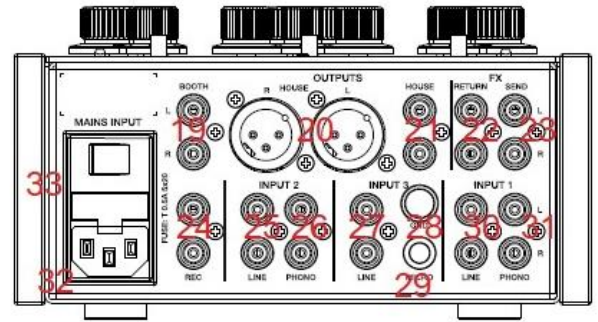

7. INSTALLATION AND CONNECTION

Warm2 is conceived as a portable desktop mixer with a small form factor and optimized to be placed between two turntables or two digital players.

We recommend to place it in a comfortable position for the end user, without placing it in direct contact with the turntables to avoid transmitting shocks and vibrations to the styluses during use.

Because of the high gain of the PHONO and MICRO inputs, always try to place the mixer as far away as possible from noise sources (dimers, engines, etc.) and mains wires.

The WARM2 operates with a universal input power supply and can perfectly works without any internal modification from 90V to 264V – 47 to 63Hz. Ensure that the mains-wire is far away from the signal-cables in order to avoid any possible audio hum.

In order to protect the unit from an eventual electrical overload it carries a T 0.5A fuse. Should it ever blow up, unplug the unit from mains and replace it with an identical one. If the new fuse blows again contact immediately with our authorized technical service.

ATTENTION: NEVER SHORT-CIRCUIT THE SECURITY PATH NOR USE A HIGHER VALUE FUSE.

CAUTION: Fuse substitutions have to be performed by a qualified technician.

Audio Input Connections

INPUT 1	PHONO	Turntable
INPUT 1	LINE	CD or Digital Deck
INPUT 2	PHONO	Turntable
INPUT 2	LINE	CD or Digital Deck
INPUT 3	MICRO	Microphone
INPUT 3	LINE	CD or Digital Deck

Phono Inputs

Phono Turntables must be fitted with a magnetic cartridge with nominal output level between -55dBV and -25dBV (1.77 to 56mVrms). The WARM2 PHONO inputs (26 and 31) have high headroom (margin before saturation) and they can handle higher output cartridges than what is usual. These inputs are supplied with a nominal input sensitivity of -40dBV (10mVrms). Act on TRIM control in order to adjust the input sensitivity depending by the cartridges in use.

Line Inputs

The sensitivity of the inputs marked as LINE (27-27-30) is 0dBV (1Vrms). You can connect sound sources such as CD or digital players, as well as keyboards and other instruments.

Microphone Input

The MIC input (29) is ready for a nominal input level of -50dBV (3.16 mVrms). The connection of balanced signals is as follows:

Hot or direct signal	>	Tip
Cold or inverted signal	>	Ring
Ground	>	Sleeve

Low impedance (200 to 600 Ω) monophonic microphones must be used. For non balanced microphones we recommend monophonic jack plugs although stereo ones are also suitable if the ring is short-circuited to the sleeve. The WARM2 includes 18V Phantom power for condenser microphones. An internal jumper allows disabling the phantom power. The WARM2 MICRO input is delivered with enabled phantom power by default (see the configuration diagram).

Audio Output Connections

HOUSE	Main power amplifier
BOOTH	Booth/Room2 power amplifier
REC	Recording
FX Send/Return	External effect devices (Input and Output)
Monitor	Headphones

HOUSE Output

This stereo output feeds the PA system through balanced XLR3 connectors (20) and an unbalanced RCA connector (21). The nominal level of HOUSE output is set to 0dBV (1Vrms) by default, but it can be set to +12dBV (4Vrms) using an internal dip-switch (look at [Configuration Diagram](#)). The HOUSE output level is controlled by the HOUSE potentiometer (14).

BOOTH Output

Commonly used as an independent local "Booth" output for the DJ. This stereo BOOTH (19) has unbalanced RCA connections and its level is set at 0dBV (1Vrms) but can be changed to +12dBV (4Vrms) through internal dip-switch (look at [Configuration Diagram](#)). The BOOTH level is controlled by the BOOTH (15) potentiometer.

Record output

This output pair uses RCA type connectors. REC (24) is placed on the rear connection panel. The nominal level of the REC output is 0dBV (1Vrms). This output is taken post-fader, before the MASTER signal.

FX Send/Return effects loop

The RCA connectors on the FX SEND output (23) and the FX RETURN input (22) allow creating a signal loop for external effects processors, samplers or sequencers. The nominal level for the SEND output, as well as for the RETURN input, is 0dBV (1Vrms).

The signal sent to the FX SEND output can be taken before or behind the fader using the PRE/POST switch (8) and the send level can be set using the related potentiometer (9).

Headphones

In order to obtain the best performances, Headphones should be high impedance type (200-600 Ω). Plug them in the MONITOR output (16) on the front panel: 1/4" and 1/8" stereo jack are available for connection. Sleeve is Ground, Ring is Right Channel and Tip is Left Channel.

8. QUICK START

Install and connect the WARM2 mixer as described in the [previous chapter](#).

This “Quick Start” guide explains a simple procedure to route and headphone monitoring a turntable.

1. Set the controllers to their initial position

Set Channel 1 TRIM, HIGH, MID and BASS (3, 4, 5 and 6) rotary controls to their central position. Set the channel potentiometer (10) to zero rotating it counter clockwise.

2. Connect your turntable

Connect your turntable to the PHONO input on channel 1 (31), choose your favourite record and start to play it.

3. Connect the headphones

Connect your headphones to the related output (16). Set the headphones VOLUME controller (17) to minimum level and move the SOURCE selector (18) to PFL position.

4. Connect the main power cable

Connect the power cable to the power supply input (32) and turn it on using the MAINS INPUT switch (33). Both elements are located on the mixer backside.

5. Select the input source

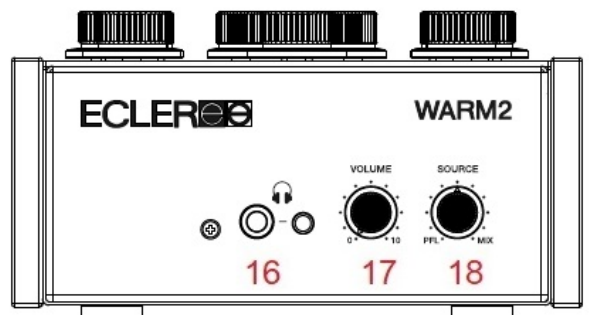
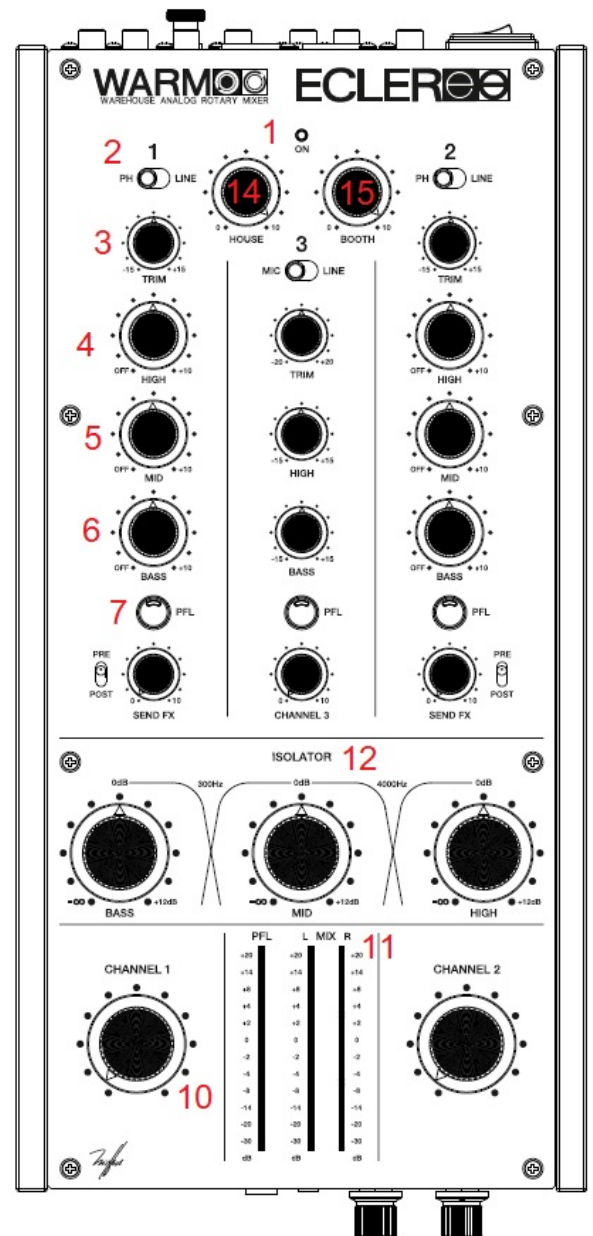
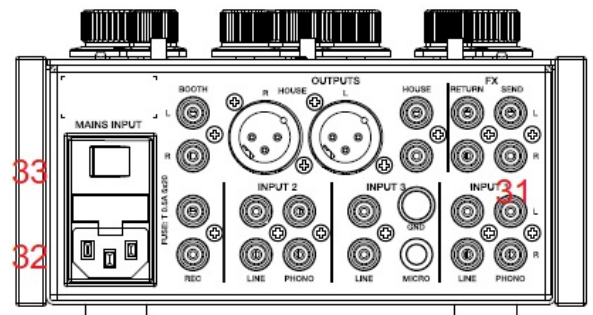

Make sure that the channel 1 input switch (2) is placed in PHONO position and press the PFL button (7). The PFL VU-meter (11) should start to work. If this doesn't happen, verify that the turntable is correctly connected and that the record is playing.

6. Adjust the input level

Move the TRIM (3) control until the VU-meter shows 0dB.

7. Send the signal to the HOUSE

Rotate the channel 1 potentiometer (10) clockwise at its maximum.

8. Monitor the output with your headphones

Adjust the VOLUME controller (17) to obtain a comfortable monitoring volume. Now you should hear music with your headphones. Turn the SOURCE controller (18) clockwise to crossfade from the PFL signal to the MIX signal. When this controller is completely turned to the right, only the MIX signal will be monitored. In this case the PFL and the MIX signal are both referred to channel 1 so you will listen the same signal in both positions.

9. Check the EQ operation

Adjust the EQ of the track with the 3-way stereo equaliser (4, 5, 6) and unleash your creativity with the powerful 3-way isolator (12). This 4th order tone control has been designed for a creative sound edition: each way can be individually isolated and boosted using the big and ergonomic rotary controllers.

9. OPERATION AND USAGE

Start-up

Switch on the mixer using the switch (33) located in the mixer back panel. Now the LED ON (1) indicator will be lit in green. Even if the typical bump noise of audio devices during the start-up is minimized in the WARM2 thanks to the internal anti-bump circuits, it is always recommendable to turn on the devices using the following sequence:

1. Sound sources
2. Mixer, sound processors, effects
3. Finally, power amplifiers

The shut-down routine should be done by following the exact reverse sequence in order to avoid any possible damage to the loudspeakers.

Control Description

Input selector

Each channel provides an input toggle switch selector (1) that allows selecting the PHONO or LINE inputs for the main channels and MIC or LINE inputs for the third channel.

Channel TRIM

All the WARM2 input channels have an accessible TRIM input sensitivity control (3). These controls adjust the input level of each channel in order to compensate the level of different sources connected to the mixer, or different phono cartridges in case of turntables.

The gain adjustments should be done with great care, using as a reference the PFL VU-meter (11). The standard level reference used to mix audio signals is 0dBV.

Equalization

The rotary tone controls for each channel provide a +10/-30dB boost/cut at high (4) and low frequencies (6) and +10/-25dB at the mid range (5). This control allows equalizing the track in use or it can be used in all the creative ways possible. In addition to the channel EQ, a powerful 3-way Isolator (12) is available on the main output. It provides a +12/-70dB boost/cut at high and low frequencies and +12/-40 dB at the mid range. This great attenuation range is specially designed for creative live performance.

ATTENTION: Use equalization carefully; by boosting too much the low frequency range, you can induce an excessive displacement of the loudspeakers membrane.

Monitoring System

WARM2 is equipped with a flexible and easy monitoring system that will allow the performers to finely tune PFL (Pre-fader listening) and Mix levels of each input through the VU-METER and the HEADPHONES. Each channel can be monitored visually and pre-listened pressing the dedicated PFL (7) button.

For HEADPHONES monitoring, the SOURCE rotary potentiometer (18) allows you to blend a selected PFL together with the main MIX Program. The VOLUME rotary potentiometer (17) controls the level of headphones output.

Sending to external effects units FX Send/Return

The 2 main channels of WARM2 are equipped with rotating potentiometers (9) that allow sending the signal to an external effects unit, sampler, etc. These potentiometers allow to precisely adjusting the signal level sent from each channel.

The FX SEND output (23) has to be connected to the effects processor's input and its output to the RETURN input (28) or any LINE input (35).

This signal send can be configured either PRE or POST fader with the PRE/POST toggle switch (10).

Potentiometers

The WARM2 is equipped with original Japanese ALPS blue velvet potentiometers that offer extremely soft and smooth transitions both for channels and isolator controls.

HOUSE and BOOTH output levels

WARM2 features two main output level controls: HOUSE and BOOTH. The master level is controlled by the HOUSE (14) level knob. The BOOTH level is controlled by the BOOTH (15) level knob.

IMPORTANT: With the default output settings of 0dBV (look at [Configuration Diagram](#)) and when the HOUSE (14) or BOOTH (15) potentiometers are at their maximum position, the output signal levels of HOUSE (20-21) and BOOTH (19) will faithfully follow the MIX VU-meter (11) indications, in order to have a real perception of the signal output.

As the MIX VU-Meter is monitoring the MIX bus and not the outputs, when the internal extra-gain of 12dBV is set on the outputs (look at [Configuration Diagram](#)) and when the HOUSE or BOOTH potentiometers are at their maximum position, the VU-Meter indications will be displaced of +12dBV: 0dBV corresponds to +12dBV.

HOUSE output (20) is electronically balanced so the unbalanced level (21) always matches with the balanced level (20).

WARM2 has extended headroom: its maximum output without distortion can reach 21dBV (23dBu)!

Take care of the devices connected to the mixer outputs checking the VU-meters and please try to stay away from the red light zone!

10. FURTHER CONSIDERATIONS

Ground loops

Avoid that the sources connected to the mixer and the devices connected to its output have their ground reference interconnected; it means that the ground reference should never have two or more different paths, because hums and noise can appear influencing the sound quality. In order to avoid ground loops, ensure that the shielding of cables, if connected to the chassis, are never connected with each other.

Background noise

The use of active circuitry can yield, depending on the configuration, to a significant noise level. The WARM2 have been specifically designed with a very reduced noise figure. Anyway, the noise level will always depend by the correct use and installation of the mixer and by the correct gain chain. It is not the same setting up the channel potentiometer at "2" and the HOUSE level at "10" that vice versa. In the first case you get a poor signal to noise ratio that will be fully amplified by the master output while on the second we have a good signal to noise ratio only amplified by "2". As a result, the background noise is greater in the first case than in the second one.

Audio connections

As a general rule of thumb, make the signal connections as short as possible and use the best connectors and cable available. Cables and connectors are frequently held cheap, forgetting that a bad connection can result in a poor sound quality.

Cleaning

The control panel should never be cleaned with solvent or abrasive substances as it could become damaged. To clean it, use a slightly moist soft cloth, together with a neutral liquid detergent, and then dry it with a clean cloth. We suggested removing all sweat stains after use. Be careful to ensure that liquids never enter in the machine through any of the openings.

11. CONFIGURATION DIAGRAM

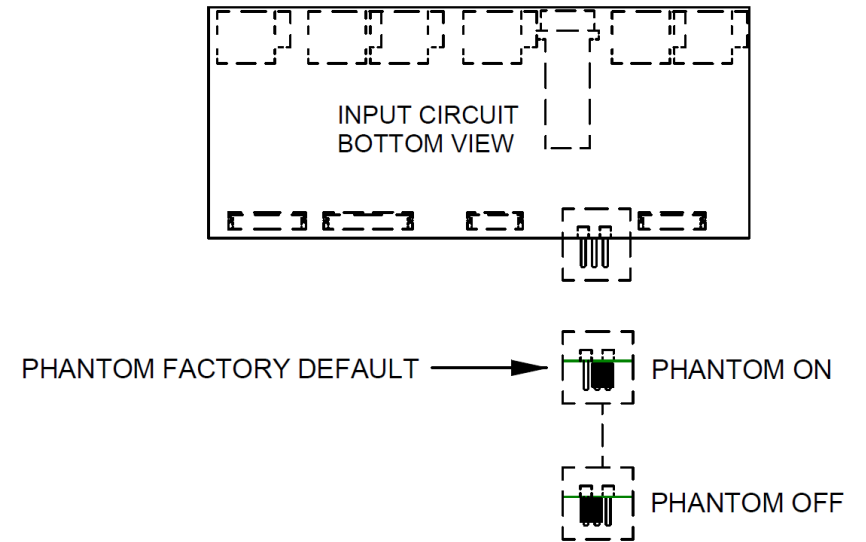
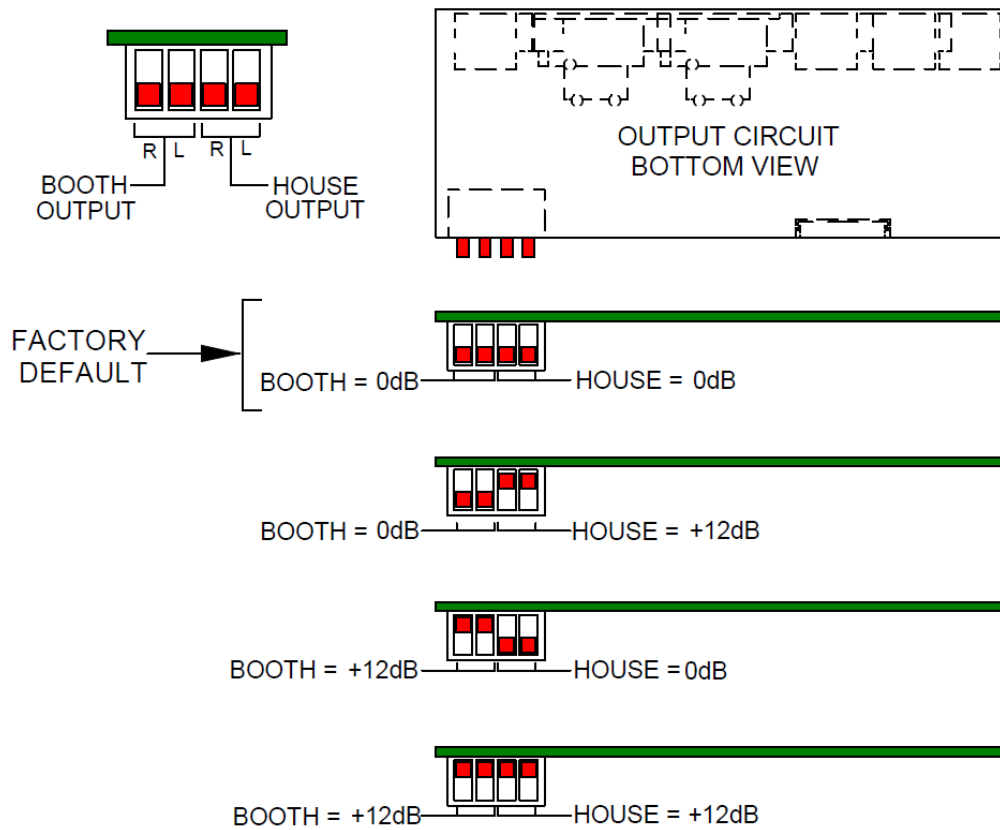

12. BLOCKS DIAGRAM

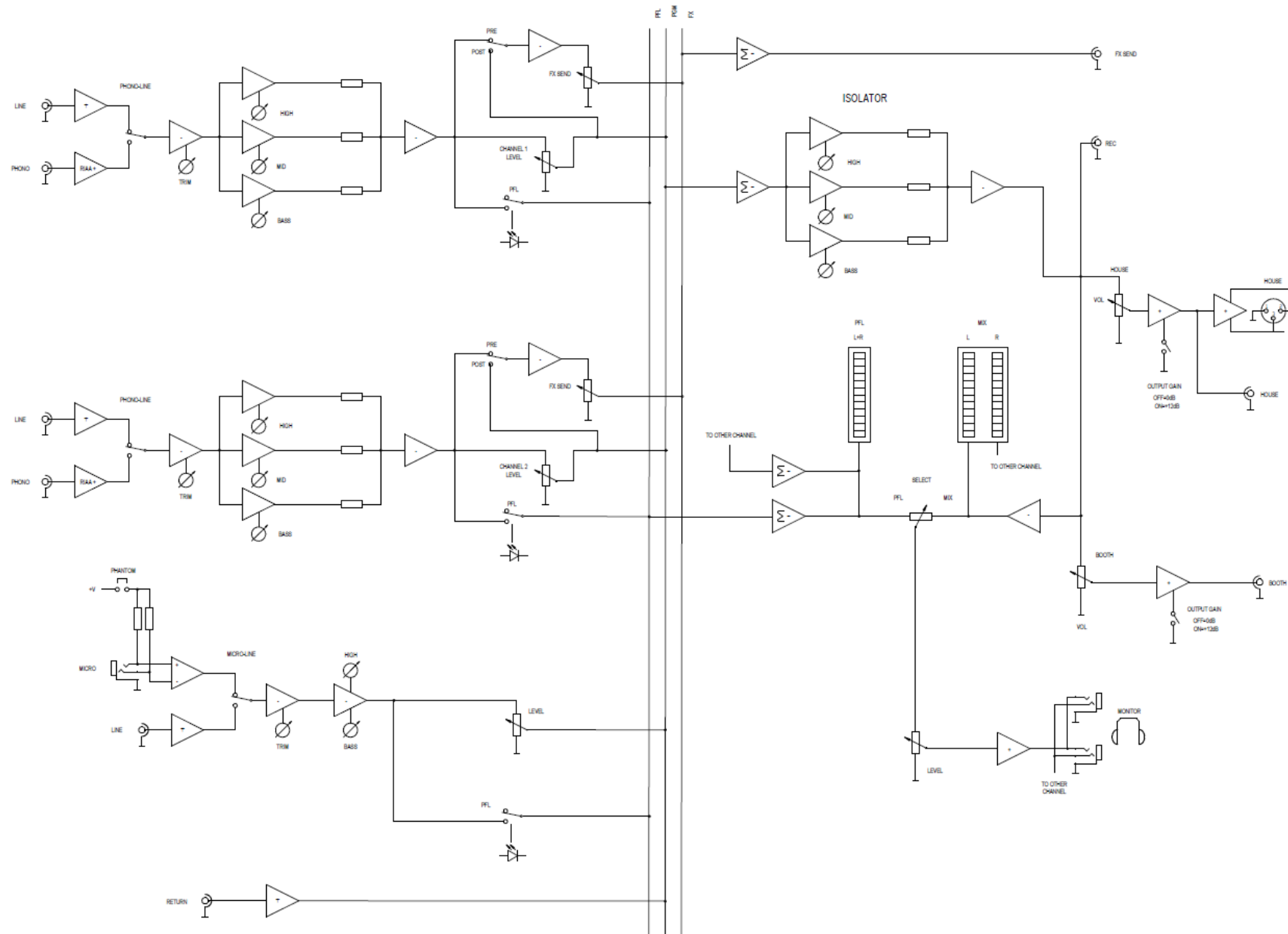

13. TECHNICAL FEATURES

WARM2

Audio Performances

Inputs Sensitivity nom/Impedance	LINE	0dBV/50kΩ
	PHONO	-40dBV/50kΩ
	MICRO	-50dBV/>1kΩ
	FX RETURN	0dBV/>6kΩ
Outputs Level/Minimum Load	HOUSE (BAL)	0dBV/600Ω 1V *(+12dB 4V)
	HOUSE (UNBAL)	0dBV/2.2kΩ 1V *(+12dB 4V)
	BOOTH (UNBAL)	0dBV/2.2kΩ 1V *(+12dB 4V)
	REC	0dBV/10kΩ
	HEADPHONES	200mΩ/200Ω THD 1%
	FX SEND	0dBV/2.2kΩ
Frequency Response	LINE	10Hz÷30kHz -1dB
	MICRO	10Hz÷25kHz -1dB
	PHONO	RIAA ±0.5dB
	FX RETURN	10Hz÷50kHz -1dB
THD+N	LINE	<0.006%
	MICRO	<0.9%
	PHONO	<0.08%
	FX RETURN	<0.005%
CMMR	MICRO	>70dB @ 1kHz
Signal Noise Ratio	LINE	>99dB
	MICRO	>85dB
	PHONO	>98dB
	FX RETURN	>100dB
Max Undistorted Output Level	HOUSE (Electr.BAL)	21dBV (23dBu)
	HOUSE (UNBAL)	21dBV (23dBu)
	BOOTH (UNBAL)	21dBV (23dBu)
Trim control	INPUTS 1-2	± 15dB
	INPUT 3	± 20dB
Tone control Inputs 1-2	BASS	+10/-30dB
	MID	+10/-25dB
	TREBLE	+10/-30dB

Tone control Input 3	BASS TREBLE	$\pm 15\text{dB}$ $\pm 15\text{dB}$
Tone control Isolator	BASS MID TREBLE	+12/-70dB +12/-40dB +12/-70dB
Tone Filter cut frequency at -6dB (slope 12dB/oct)	BASS MID TREBLE	200Hz 200Hz÷6.8kHz 6.8kHz
Isolator cut frequency at -6dB (slope 24dB/oct)	BASS MID TREBLE	300Hz 300Hz÷4kHz 4kHz
Inputs		
Connectors	LINE 1-2-3 PHONO 1-2 MICRO 3 FX RETURN	RCA STEREO RCA STEREO 6.3mm TRS BAL. JACK RCA STEREO
Outputs		
Connectors	HOUSE (BAL) HOUSE (UNBAL) BOOTH FX SEND REC HEADPHONES	XLR STEREO RCA STEREO RCA STEREO RCA STEREO RCA STEREO 6.3mm/3.5mm STEREO JACK
Miscellaneous		
Control Mode	Rotary with Alps Blue Velvet Potentiometers	
Phantom Voltage	18VDC/5mA Max (Default ON)	
MIX and PFL VU-Meter	LED 12 segments (-30dBV ÷ +20dBV)	
Operation		
Operation Temperature	-5°C - 45°C / 23°F - 113°F	
Humidity	20 - 90% RH (no condensation)	
Supply		
Mains voltage	90-264VAC 47-63Hz	
Rated power consumption	30VA	
Mechanical		

Dimensions (without wooden sides)	400 x 185 x 100mm / 15.7" x 7.2" x 3.9"
Weight	3.6Kg / 7.94 lbs

14. ECLER SIGNATURE



WARM2 shows the classic Niiffics signature on the front plate. This is the historical signature of the R&D teams at Ecler during the years.

All product characteristics are subject to variation due to production tolerances.

NEEC AUDIO BARCELONA S.L. reserves the right to make changes or improvements in design or manufacture that may affect these product specifications.

For technical queries please contact your supplier, distributor or complete the contact form on our website under Support / [Technical Query](#). Motors, 166-168 08038 Barcelona - España - (+34) 932238403 | eclerdj@ecler.com | www.eclerdj.com