

## eCMP12

### SPECIALIZED LOUDSPEAKERS

#### *Musical Projector*

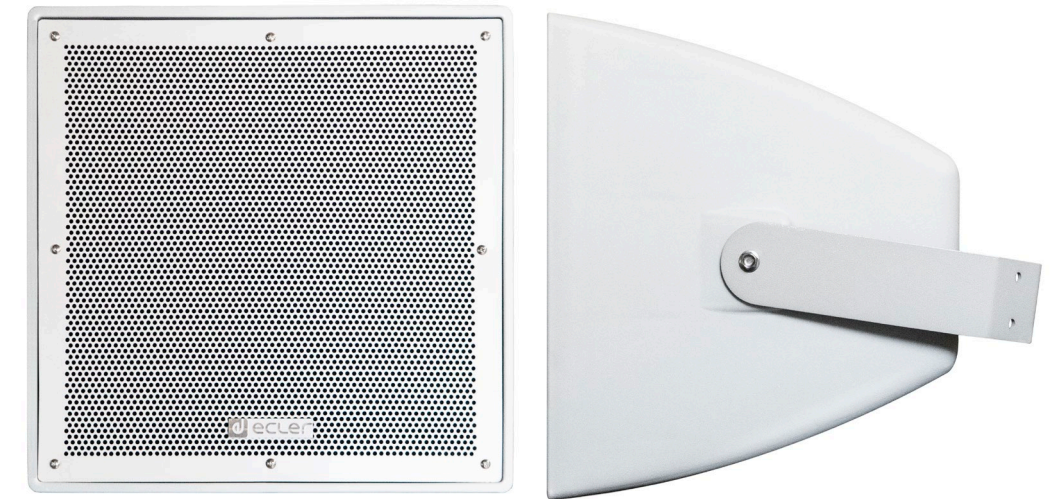

### PRODUCT OVERVIEW

eCMP12 is a 300W high efficiency musical projector ready for outdoor applications due to its waterproof and sun screening building material (IP56). It performs a 12" LF driver and 1,7" HF coaxial driver, 300W @ 8 $\Omega$  nominal power and 70/100V line transformer with 50/100/200W/8 $\Omega$  power options.

### KEY FEATURES

- Weatherproof 2-way music projector.
- 300 W @ 8 $\Omega$
- Power options 100V: 50/100/200W/OFF and 8  $\Omega$
- Power options 70V: 25/50/100W/OFF and 8  $\Omega$
- Input & output connection via terminal block
- Frequency response (-10dB): 91 Hz-20 kHz
- Dispersion (HxV): 107° x 107°
- Material: Polypropylene, aluminium (grille), hot-dipped galvanized steel (U-bracket)
- Weather-resistant IP56 rating

### APPLICATIONS

- Commercial
- Hospitality
- Education
- Corporate
- Sports and wellness
- House of worship
- Leisure

## TECHNICAL SPECIFICATIONS

## eCMP12

System	
Effective frequency range <sup>1</sup>	91 Hz-20 kHz (-10dB)
Coverage angle <sup>2</sup>	107°x107°
Power handling	300 W RMS / 1200 W Peak
Sensitivity <sup>3</sup>	100 dB (1W/1m)
Maximum SPL <sup>4</sup>	125 dB continuous / 131 dB peak
Power options	100V: 50/100/200W/OFF and 8 Ω 70V: 25/50/100W/OFF and 8 Ω
Recommended amplifier power	600 W RMS
Transducers	
Ways	2-ways long throw
Low Frequency driver	12"
High Frequency driver	1,7" coaxial
Nominal impedance	8Ω
Filters	
Crossover filter	2,1 kHz
Physical	
Connection type	Terminal block (input+output)
Environmental	IP56 rated
Enclosure material	Polypropylene
Grille material	Aluminium
Mounting system	Hot-dipped galvanized steel U-bracket
Operating temperature	Min: -10°C; 14°F Max: 40°C; 104°F
Operating humidity	<85% HR
Storage temperature	Min: -10°C; 14°F Max: 40° ; 104°F
Storage humidity	<90% HR
Finished color	Grey (RAL 538C)
Dimensions (WxHxD)	407 x 410 x 378 mm / 16.0 x 16.1 x 14.9 in. (If the mounting bracket is added the total depth will be 443mm / 17.45")
Weight	20.0 kg / 44.1 lb
Shipping Dimensions (WxHxD)	475 x 490 x 445 mm / 18.7 x 19.29 x 17.52 in.
Shipping Weight	21.3 kg / 46.96 lb

<sup>1</sup>10dB below the sound pressure level at specified sensitivity

<sup>2</sup>6dB below the sound pressure level than that at the direction of maximum level. Max. angle between 1 kHz and 4 kHz.

<sup>3</sup>Measured on-axis, far field and referenced to 1 meter by inverse square law. Average from 100 Hz to 10 kHz.

<sup>4</sup>Calculated from sensitivity and power handling specifications, exclusive of power compression

FREQUENCY RESPONSE

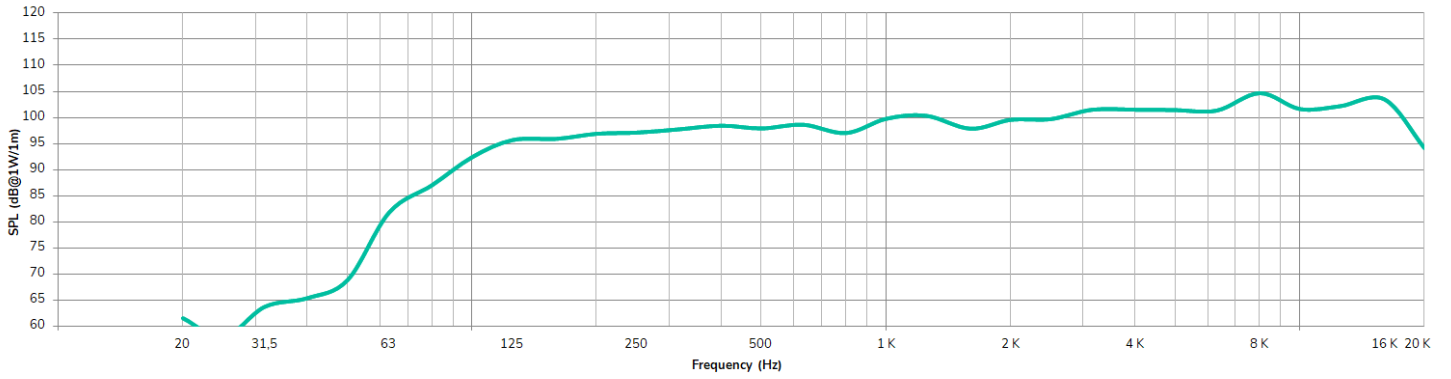

POLAR DIAGRAMS

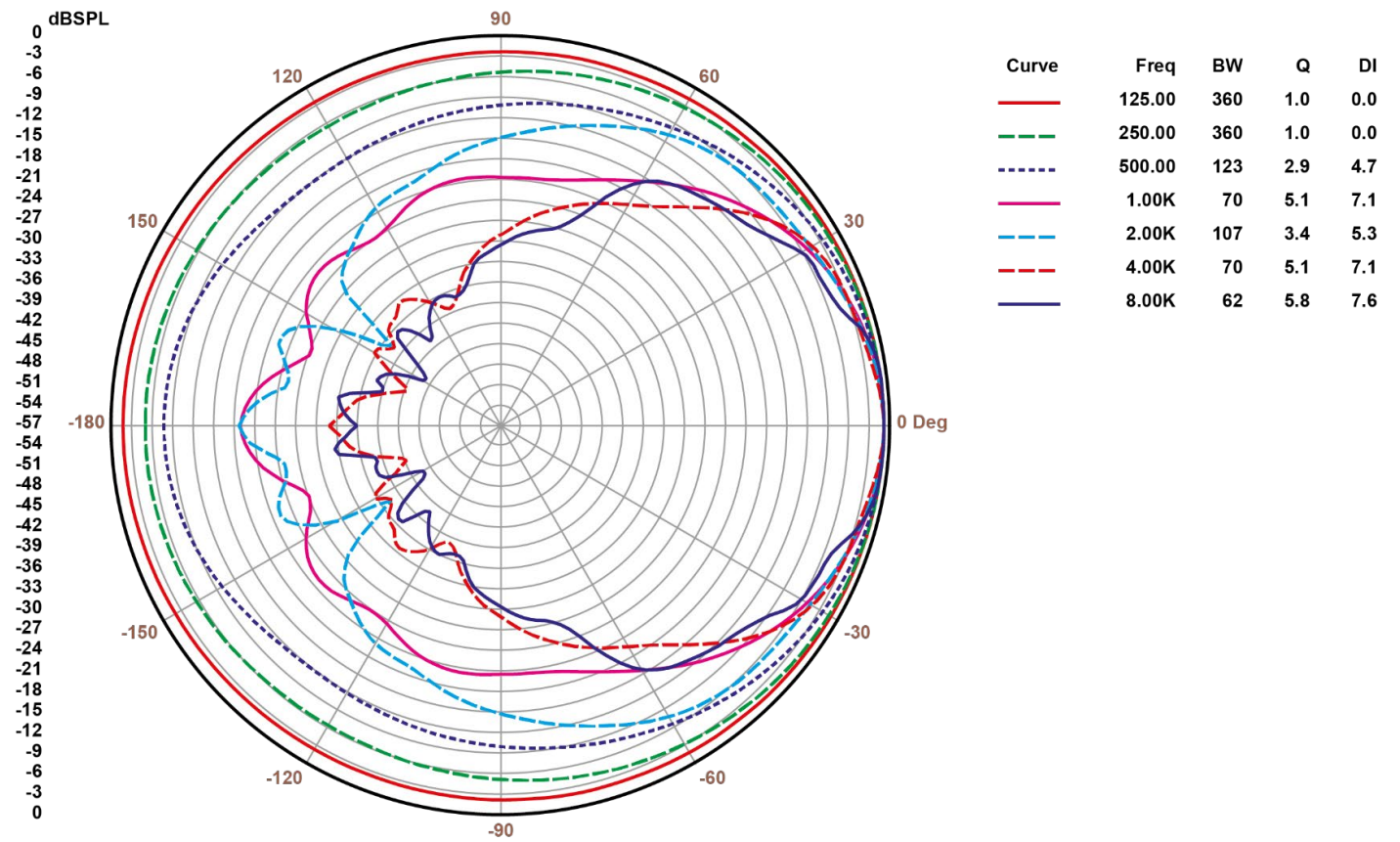

MECHANICAL DIAGRAMS

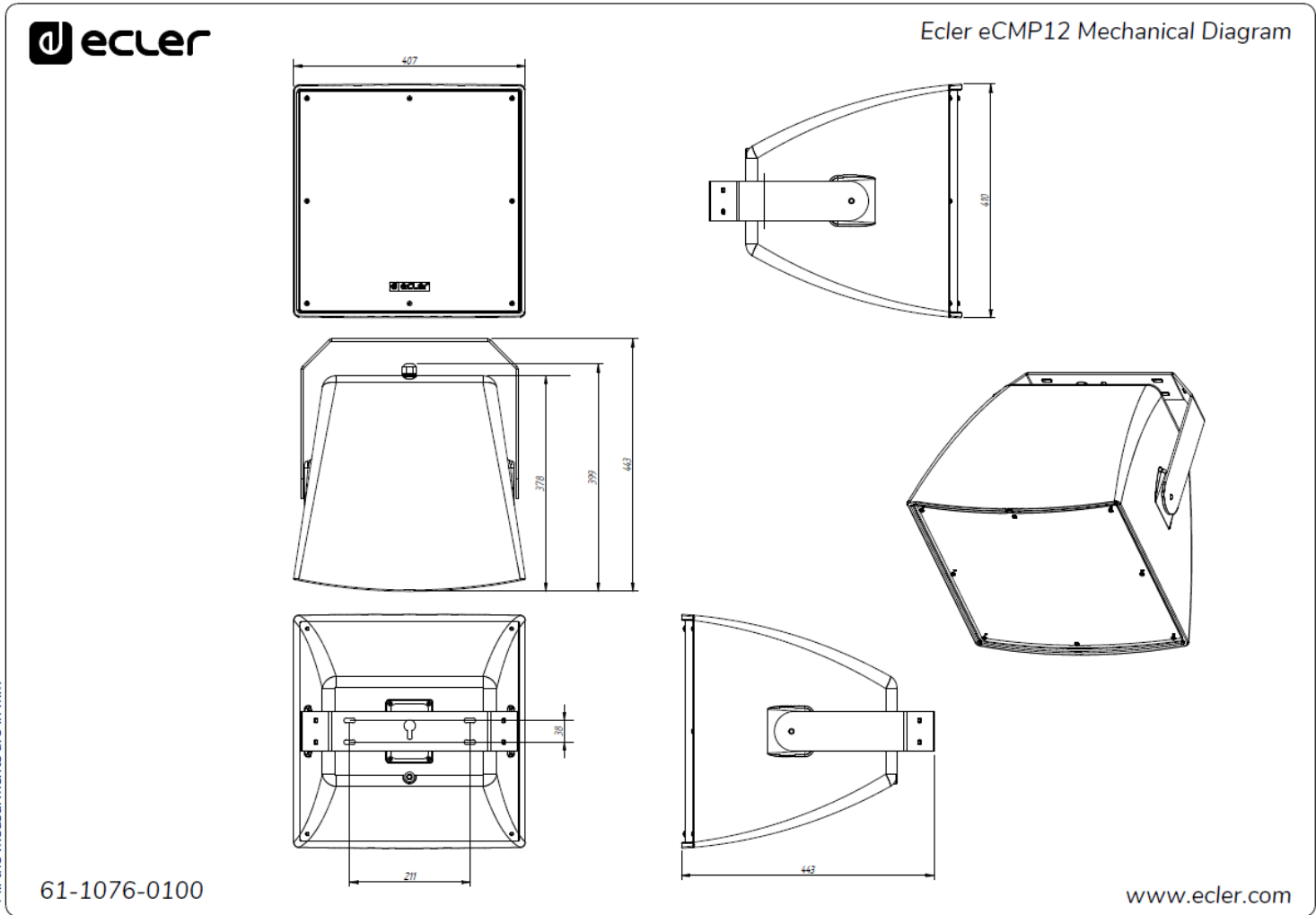

All product characteristics are subject to variation due to production tolerances. **NEEC AUDIO BARCELONA S.L.** reserves the right to make changes or improvements in the design or manufacturing that may affect these product specifications.

For technical queries contact your supplier, distributor or complete the contact form on our website, in [Support / Technical requests](#).

Motors, 166-168 08038 Barcelona - Spain - (+34) 932238403 | [information@ecler.com](mailto:information@ecler.com) | [www.ecler.com](http://www.ecler.com)