

# AMBIT-16

## COMMERCIAL LOUDSPEAKERS

### Surface Mount Cabinets

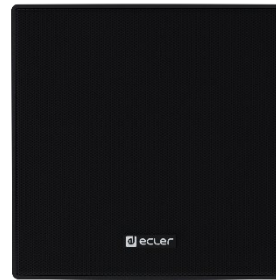
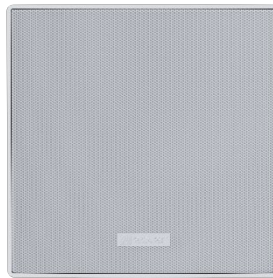

## PRODUCT OVERVIEW

**AMBIT-16** is a compact 2-way coaxial loudspeaker cabinet with neutral and discreet design. It mounts a 6.5" woofer and a 1" tweeter, and it is suitable for low and high impedance lines. AMBIT-16 is ready for indoor and outdoor applications, thanks to its aluminium grill and UV protection treatment (IP54-rated). Wall mount accessories and safety sling are included for an easy and secure installation.

## KEY FEATURES

- ABS 2-way architectural loudspeaker.
- 6.5" woofer / 1" Tweeter.
- Built-in audio transformer for 100V applications.
- 8Ω and 70/100V operation selector.
- Available in black (RAL9005) and white (RAL9016) colours.
- Spring loaded input terminals.
- IP54 rated.
- Anti UV cabinet avoids colour degradation in case of direct sunlight exposition.
- Waterproof rubber cover for connectors included.
- [EASE files available](#)



## APPLICATIONS

- Retail
- Corporate
- Sports & Wellness
- Hospitality

## TECHNICAL SPECIFICATIONS

## AMBIT-16

System	
Effective frequency range <sup>1</sup>	97Hz-20kHz (-10dB)
Coverage angle <sup>2</sup>	143°x140° (HxV)
Power handling	50 W RMS / 200 W Peak
Sensitivity <sup>3</sup>	91 dB (1W/1m)
Maximum SPL <sup>4</sup>	108 dB continuous / 114 dB peak
Power options	100V: 5W / 7.5W / 15W / 30W 70V: 2.5W / 3.75 W / 7.5W / 15W
Recommended amplifier power	100 W RMS
Transducers	
Ways	2-ways full range
Low frequency driver	6,5" woofer
High frequency driver	1" tweeter
Nominal impedance	8Ω
Physical	
Connection type	Spring loaded input terminals
Installation options	Surface, ceiling, corner (wall mount)
Environmental	IP54 rated
Enclosure material	ABS plastic
Grille material	aluminium
Operating temperature	Min: -10°C ; 14°F Max: 50°C ; 122°F
Operating humidity	<85% HR
Storage temperature	Min: -10°C ; 14°F Max: 50°C ; 122°F
Storage humidity	<90% HR
Included accessories	Includes on-wall hardware, safety sling, screws and wrench for fast installation, and waterproof rubber cover for connectors.
Finished colour	White (RAL 9016) or black (RAL 9005)
Dimensions (WxHxD)	210 x 210 x 160 mm / 8.27 x 8.27 x 6.30 in
Weight	2.75 kg / 6.06 lb
Pieces per box	2
Shipping dimensions (WxHxD)	420 x 272 x 465 mm / 16.54 x 10.71 x 18.31 in.
Shipping weight	6.10 kg / 13.45 lb

<sup>1</sup>10dB below the sound pressure level at specified sensitivity

<sup>2</sup>6dB below the sound pressure level than that at the direction of maximum level. Max. angle between 1 kHz and 4 kHz.

<sup>3</sup>Measured on-axis, 2,83V, far field and referenced to 1 meter by inverse square law. Average from 100 Hz to 10 kHz.

<sup>4</sup>Calculated from sensitivity and power handling specifications, exclusive of power compression

### FREQUENCY RESPONSE ON-AXIS

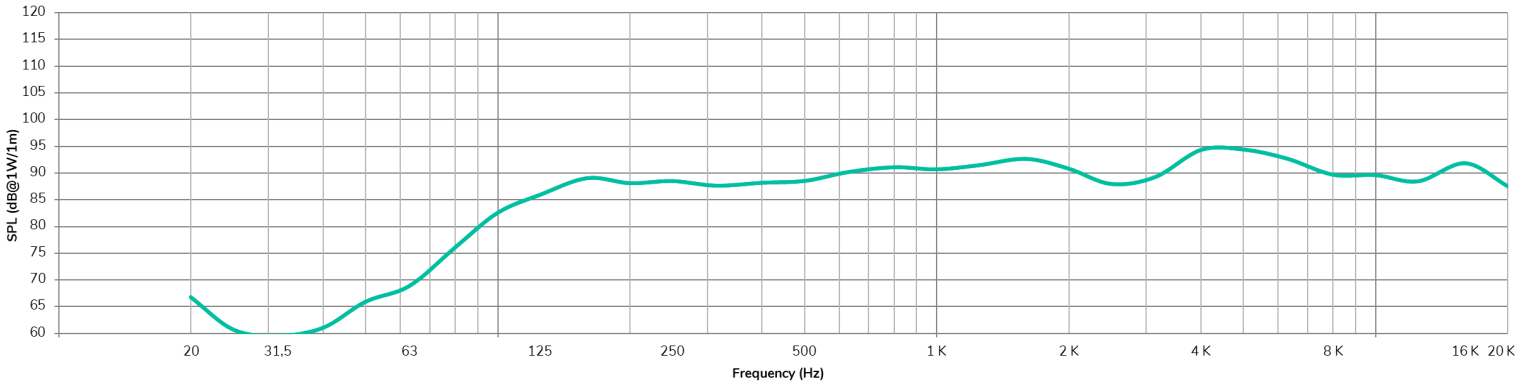

### POLAR DIAGRAMS

#### HORIZONTAL

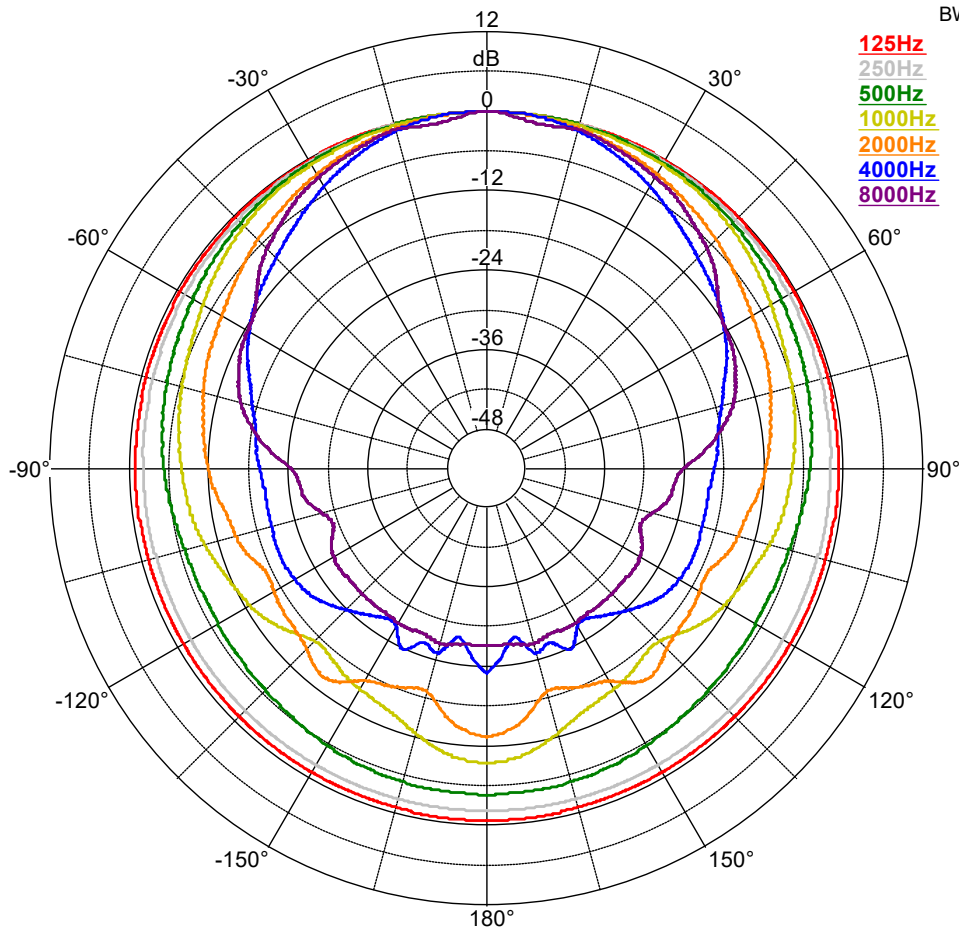

	BW	Q	Di
125Hz	360	1.2	0.7
250Hz	360	1.4	1.5
500Hz	195	2.1	3.3
1000Hz	143	3.1	4.9
2000Hz	100	4.5	6.5
4000Hz	67	6.5	8.1
8000Hz	106	3.2	5.1

VERTICAL

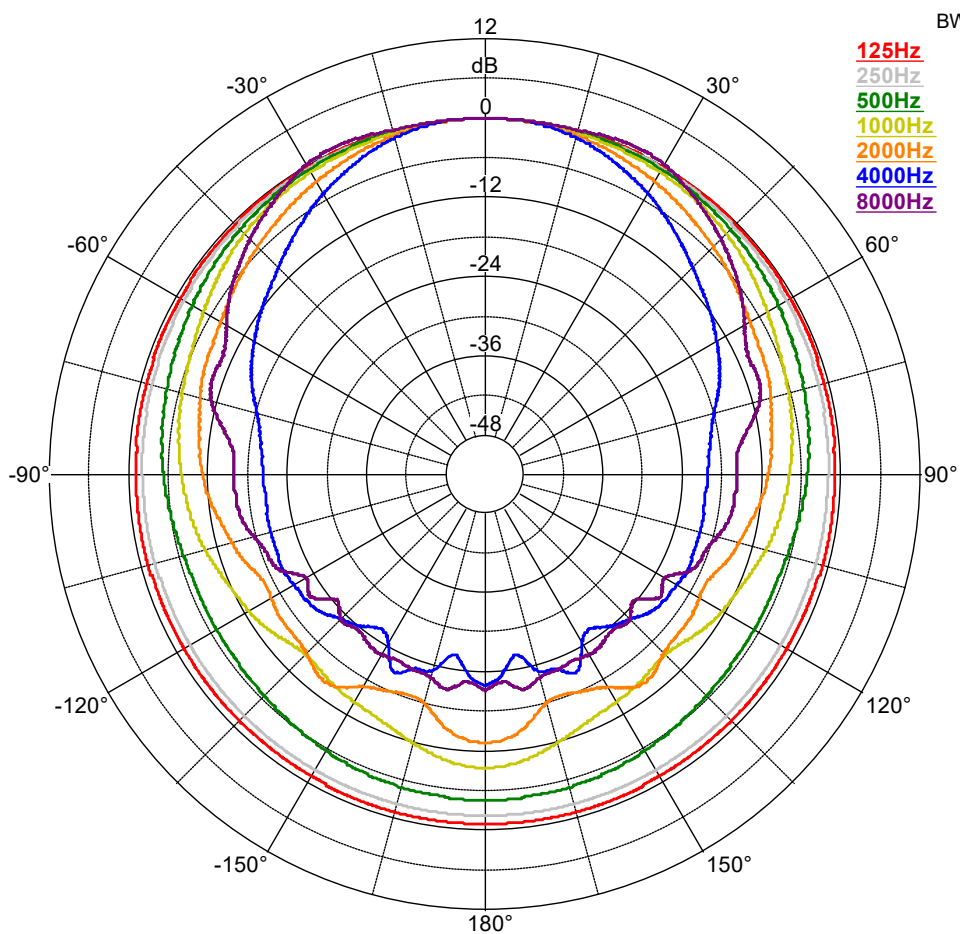

	BW	Q	Di
125Hz	360	1.2	0.8
250Hz	360	1.4	1.5
500Hz	195	2.1	3.3
1000Hz	140	3.2	5.0
2000Hz	99	4.5	6.5
4000Hz	67	6.7	8.2
8000Hz	106	3.7	5.7

## MECHANICAL DIAGRAM

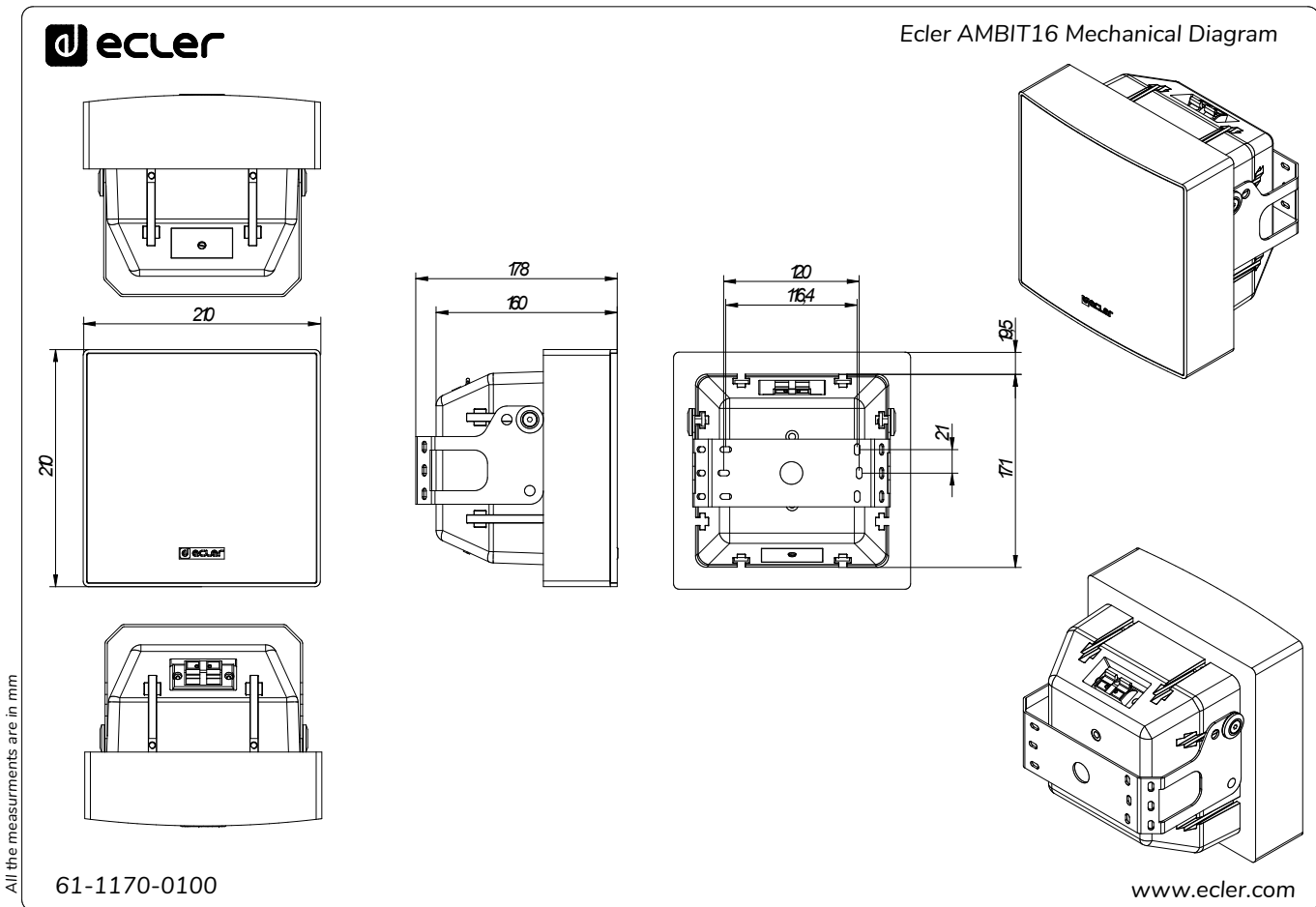

## A&amp;E SPECIFICATIONS

The loudspeaker shall be a 2-way full range wall-mount type consisting of a 6.5" woofer and a 1" tweeter suitable for 70/100 V line or low impedance installations. The power handling should be 50 W RMS at a nominal impedance of  $8 \Omega$  with a peak power handling of 200 W. It shall include a multi-tapping line transformer with tapings 5W / 7.5W / 15W / 30W @ 100V and 2.5W / 3.75 W / 7.5W / 15W @ 70V.

The effective frequency range ( $\pm 10$  dB) shall be from 97 Hz to 20 kHz. The sensitivity shall be 91dB considering 1 W input signal at 1 meter distance. The maximum continuous sound pressure level shall be 108 dB, while the maximum peak pressure level shall be 114 dB considering the loudspeaker's rated power. The coverage angle shall be  $143^\circ \times 140^\circ$  (HxV) coverage pattern.

The enclosure shall be made of ABS plastic and the grill shall be made of aluminium. It shall be IP54 rated for outdoors installation. It shall come available in both white (RAL9016) and black (RAL9005) colours. Connection shall be made via terminal block, including wall-mount bracket, back rubber cover and safety sling.

The loudspeaker shall have a width of 210 mm, a high of 210 mm and a depth of 160 mm. The weight shall not exceed 2.75 kg. It shall have data files available that can be used with EASE acoustic simulation software.

The loudspeaker shall be the ECLER AMBIT-16.



All product characteristics are subject to variation due to production tolerances. **NEEC AUDIO BARCELONA S.L.** reserves the right to make changes or improvements in the design or manufacturing that may affect these product specifications.

For technical queries contact your supplier, distributor or complete the contact form on our website, in [Support / Technical requests](#).

Motors, 166-168 - 08038 Barcelona - Spain | Tel. (+34) 932238403 | [information@ecler.com](mailto:information@ecler.com) | [www.ecler.com](http://www.ecler.com)