

NIC Series

LOUDSPEAKERS

In-ceiling / In-wall Loudspeaker

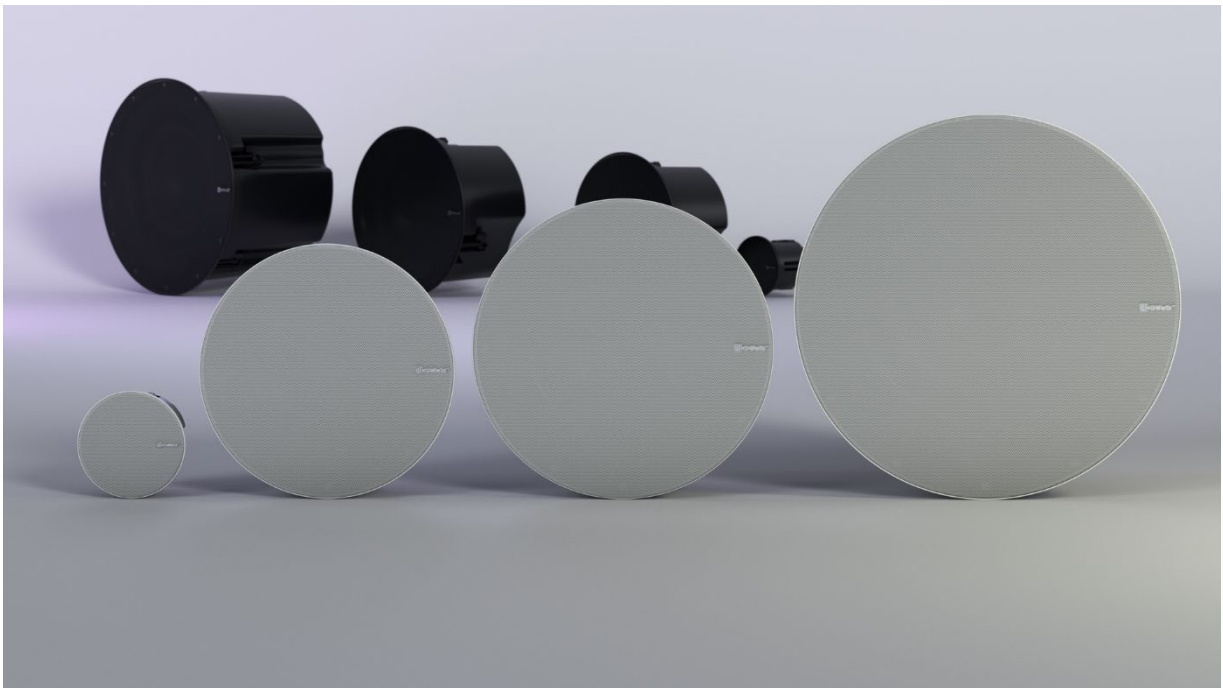

USER MANUAL



PRECAUTIONS
WARRANTY & ENVIRONMENT
PACKAGE CONTENTS
DESCRIPTION & FEATURES
CONNECTORS
LOCATION & ASSEMBLY
TECHNICAL DATA

TABLE OF CONTENTS

1. PRECAUTIONS.....	3
1.1 Important Notice.....	3
1.2 Key Safety Directions.....	4
1.3 Cleaning Directions.....	4
2. WARRANTY & ENVIRONMENT	5
3. PACKAGE CONTENTS.....	5
4. DESCRIPTION & FEATURES	6
4.1 Main Features.....	6
4.1.1 NIC-3.....	6
4.1.2 NIC-6.....	7
4.1.3 NIC-8.....	7
5. CONNECTIONS	8
5.1 NIC-3.....	8
5.2 NIC-6 & NIC-8.....	9
6. LOCATION & ASSEMBLY.....	10
6.1 Installation in ceiling.....	10
6.2 Installation in suspended ceiling.....	11
7. TECHNICAL DATA	12
7.1 Technical Specifications.....	12
7.1.1 NIC-3.....	12
7.1.2 NIC-6.....	13
7.1.3 NIC-8.....	14
7.2 Mechanical Diagram.....	15
7.2.1 NIC-3.....	15
7.2.2 NIC-6.....	16
7.2.3 NIC-8.....	17

	PRECAUTIONS
	WARRANTY & ENVIRONMENT
	PACKAGE CONTENTS
	DESCRIPTION & FEATURES
	CONNECTORS
	LOCATION & ASSEMBLY
	TECHNICAL DATA

1. PRECAUTIONS

1.1 Important Notice



WARNING: SHOCK HAZARD - DO NOT OPEN

AVIS: RISQUE DE CHOC ÉLECTRIQUE - NE PAS OUVRIR



The flashing light with an arrowhead symbol inside an equilateral triangle on it is intended to alert the user of the presence of non-insulated “dangerous voltage” within the enclosure, which might be of sufficient magnitude to pose a risk of electric shock to users.



The exclamation mark within an equilateral triangle is intended to alert the user of the requirement for important operating and maintenance (servicing), for which instructions may be found in the literature accompanying the appliance.

WARNING (If applicable): Terminals marked with symbol “⚡” may be of sufficient magnitude to pose a risk of electric shock. The external wiring connected to terminals requires installation by a technician, or the use of ready-made leads or cords.

WARNING: To prevent fire or shock hazard, do not expose this equipment to rain or humidity.

WARNING: A device with Class I manufacturing ought to be connected to a mains socket outlet with a protective earthing connection.



WARNING: Ecler products have a long lifetime of more than 10 years. This product must never be discarded as unsorted urban waste, but must be taken to the nearest electrical and electronic waste treatment centre.

	PRECAUTIONS
	WARRANTY & ENVIRONMENT
	PACKAGE CONTENTS
	DESCRIPTION & FEATURES
	CONNECTORS
	LOCATION & ASSEMBLY
	TECHNICAL DATA

1.2 Key Safety Directions

1. Read the following directions.
2. Keep the following directions.
3. Observe all warnings.
4. Follow all instructions.
5. Do not use this device in proximity to water.
6. Clean only with a dry cloth.
7. Do not block any ventilation openings. Install in accordance with the manufacturer's instructions.
8. Do not install near any heat sources such as radiators, heat registers, stoves, or other devices (including amplifiers) that may release heat.
9. Do not defeat the safety purpose of the polarized or grounding type plug. A polarized plug has two blades, with one being wider than the other. A grounding type plug has two blades and a third grounding prong. The wide blade or the third prong are provided for your safety. If the provided plug does not fit into your outlet, contact a qualified electrician for a replacement of the obsolete outlet.
10. Protect the power cord from being walked on or pinched, particularly at the plugs, convenience receptacles, and at the point of exit from the device.
11. Only use attachments/accessories specified by the manufacturer.
12. Unplug the device during lightning storms or when unused for long periods.
13. Refer all servicing to qualified personnel. Servicing is required when the device has been damaged in any way, such as power supply cord or plug damage, liquid spillage or objects onto the device, the device has been exposed to rain or humidity, does not operate normally, or has been dropped.
14. Disconnecting from mains: When switching off the POWER switch, all the functions and light indicators of the unit will be stopped, but fully disconnecting the device from mains is done by unplugging the power cable from the mains input socket, therefore, it should always remain easily accessible
15. Equipment is connected to a socket-outlet with an earthing connection by means of a power cord.
16. The marking information is located at the top, rear or bottom of the unit.
17. The device shall not be exposed to dripping or splashing liquids, and no liquid-filled objects, such as a filled up glass, shall be placed on top of the device.

1.3 Cleaning Directions



Clean the unit with a soft, dry clean cloth or slightly wet with water and neutral liquid soap only, then dry it with a clean cloth. Be careful that water never gets into the unit through any hole. Never use alcohol, benzine, solvents or abrasive substances to clean this unit.

NEEC AUDIO BARCELONA, S.L. accepts no liability for any damage that may be caused to people, animal, or objects due to failure to comply with the warnings above.

	PRECAUTIONS
	WARRANTY & ENVIRONMENT
	PACKAGE CONTENTS
	DESCRIPTION & FEATURES
	CONNECTORS
	LOCATION & ASSEMBLY
	TECHNICAL DATA

2. WARRANTY & ENVIRONMENT

**Thank you for choosing our Ecler NIC Series!
We greatly value your trust.**

It is **VERY IMPORTANT** to carefully read this manual and to fully understand its contents before any connecting takes place in order to make the best use of this equipment, as well as to get the best performance from it.

To ensure optimal operation of this device, **we strongly recommend that its maintenance be carried out by our authorised Technical Services.**

All ECLER products are covered by warranty, please refer to www.ecler.com or the warranty card included with this product for the period of validity and conditions.



Ecler is truly committed with the environment and planet sustainability, energy saving and CO₂ emission reduction. Recycling materials and using non-contaminant components are also top priorities in our green crusade.

Ecler has deeply evaluated and analyzed the environmental impacts of all the processes involved in the production of this product, including packaging, and has alleviated, reduced and/or compensated for them.

3. PACKAGE CONTENTS

- 1x loudspeaker unit (NIC-3, NIC-6, or NIC-8 model).
- Euroblock connector (4-pin).
- 1x Cutting template.
- 1x First Steps Guide.
- 1x Warranty card.



PRECAUTIONS

WARRANTY & ENVIRONMENT

PACKAGE CONTENTS

DESCRIPTION & FEATURES

CONNECTORS

LOCATION & ASSEMBLY

TECHNICAL DATA

4. DESCRIPTION & FEATURES

Ecler's NIC series in-ceiling / in-wall loudspeakers combine a sleek, minimalist aesthetic with practical features that make installation easy. Their easily removable frameless grill design ensures a clean finish and simple fastening: a bayonet-mounted aluminium grill on the NIC-3, and a magnetic grill on the NIC-6 and NIC-8. The Ecler logo is easily removable by pulling it off the grill, allowing for discreet integration into any environment.

NIC Series loudspeakers are engineered as high-performance audio solutions, delivering true Hi-Fi sound reproduction. All models include a 70/100 V line transformer and support low-impedance operation, with a power selector and front-mounted connector that allow easy configuration and wiring adjustments even after installation - except for the NIC-3, whose connector and selector are located on the rear.

NIC Series elevates ceiling speaker performance with ART (Acoustic Resonator Technology), validated by laboratory measurements. ART significantly reduces low-frequency distortion and mechanical vibration, minimising energy transfer to ceiling structures and reducing resonance, coloration and unwanted low-frequency excitation in false ceilings.

With an IP66 rating, NIC Series loudspeakers are built for reliable performance in demanding environments.

The NIC series comprises three models: NIC-3, NIC-6, and NIC-8.

4.1 Main Features

4.1.1 NIC-3

- 1-way in-ceiling loudspeaker, 20 WRMS.
- 3" woofer.
- ART Technology Backcan.
- Euroblock connector.
- 8 Ω nominal impedance.
- High impedance built-in transformer, allowing connected three positions: 8 Ω -70V-100V.
- IP66 rated.
- Bayonet Aluminium frameless front grill easily removable.
- The Ecler logo is removable.
- Fast installation procedure using a basic set of tools.
- Suitable for ceilings and suspended ceilings, with no additional accessories required.
- Available in white (RAL 9003).
- Optional black grill finish (RAL 9005) available with NICRG3BK accessory.
- **EASE files available.**

4.1.2 NIC-6

- 2-way in-ceiling loudspeaker, 50 WRMS.
- 6.5" woofer + 1" steerable dome tweeter.
- ART Technology Backcan.
- Euroblock connector accessible from the front panel.
- 8 Ω nominal impedance.
- High impedance built-in transformer, allowing for multiple units connected to a 70V / 100V line audio amplifier.
- 8 Ω or high impedance power selection accessible from the front panel, even when the loudspeaker is already installed in the ceiling.
- IP66 rated.
- Magnetic frameless front grill easily removable.
- The Ecler logo is removable.
- Available in white (RAL 9003).
- Optional black grill finish (RAL 9005) available with NICRG6BK accessory.
- Optional tile bridge (NIC-TB6) for securing the loudspeaker in suspended ceilings.
- **EASE files available.**

4.1.3 NIC-8

- 2-way in-ceiling loudspeaker, 70 WRMS.
- 8" woofer + 1" steerable dome tweeter .
- ART Technology Backcan.
- Euroblock connector accessible from the front panel.
- 8 Ω nominal impedance.
- High impedance built-in transformer, allowing for multiple units connected to a 70V / 100V line audio amplifier.
- 8 Ω or high impedance power selection accessible from the front panel, even when the loudspeaker is already installed in the ceiling.
- IP66 rated.
- Magnetic frameless front grill easily removable.
- The Ecler logo is removable.
- Fast installation procedure using a basic set of tools.
- Available in white (RAL 9003).
- Optional black grill finish (RAL 9005) available with NICRG8BK accessory.
- Optional tile bridge (NIC-TB8) for securing the loudspeaker in suspended ceilings. ?.
- **EASE files available.**

	PRECAUTIONS
	WARRANTY & ENVIRONMENT
	PACKAGE CONTENTS
	DESCRIPTION & FEATURES
	CONNECTORS
	LOCATION & ASSEMBLY
	TECHNICAL DATA

5. CONNECTIONS

The NIC series are shipped from factory with the switch in 100V/70V position. If it is connected to a low-impedance amplifier, the speaker will not be damaged but will operate significantly below its full potential.

! If the speaker is accidentally connected to a 100V/70V line in the 8Ω position, it will be severely damaged.

💡 If the loudspeaker is used in installations at 70V, the corresponding powers for the 100V position will be reduced to half.

! Always respect the polarity.

5.1 NIC-3

In the NIC-3 model, the connection terminals and the selector are located on the rear of the loudspeaker. First set the switch to the desired operating mode (70 V / 100 V / 8 Ω), then connect the cables.



PRECAUTIONS

WARRANTY
&
ENVIRONMENT

PACKAGE
CONTENTS

DESCRIPTION
&
FEATURES

CONNECTORS

LOCATION
&
ASSEMBLY

TECHNICAL
DATA

5.2 NIC-6 & NIC-8

In the NIC-6 and NIC-8 models, the connection terminals and the selector are located on the front of the loudspeaker, beneath the grill. This is especially useful for easily modifying the configuration at a later stage without the need to remove the loudspeaker from the ceiling.

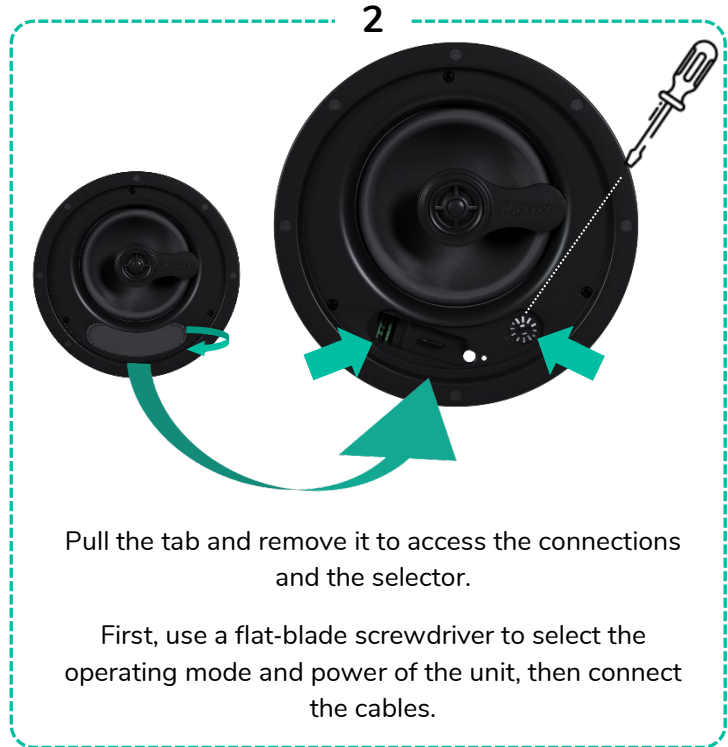
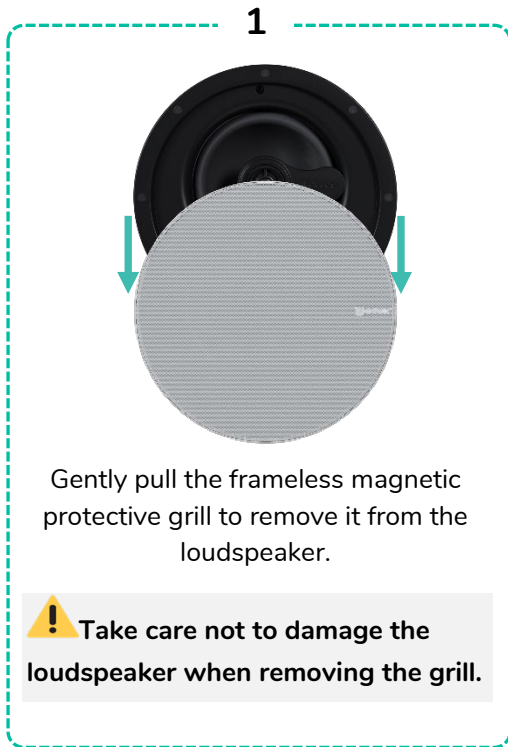

PRECAUTIONS

WARRANTY
&
ENVIRONMENT

PACKAGE
CONTENTS

DESCRIPTION
&
FEATURES

CONNECTORS

LOCATION
&
ASSEMBLY

TECHNICAL
DATA

6. LOCATION & ASSEMBLY

To install this product correctly, it is necessary to cut circular holes in the false ceiling at the desired speaker locations and ensure the necessary wiring is in place for each unit.

6.1 Installation in ceiling

1

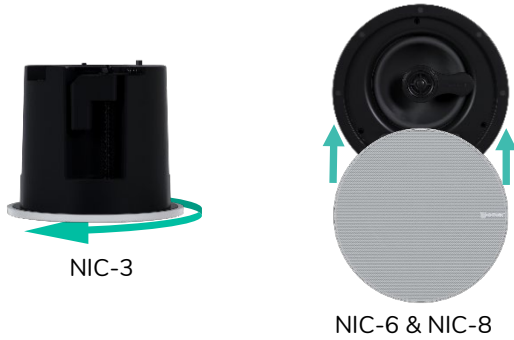

For the NIC-3, rotate the frameless grill to release it from the loudspeaker.

For the rest of the models, gently pull the frameless magnetic protective grill to remove it from the loudspeaker.

! Take care not to damage the loudspeaker when removing the grill.

2

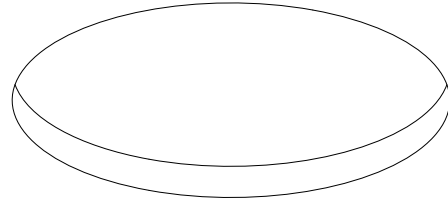

Use the cutting template provided with each unit to mark and cut a circular hole in the false ceiling.

3

Connect the cables to the device, **following the instructions provided in the Connections chapter.**

4

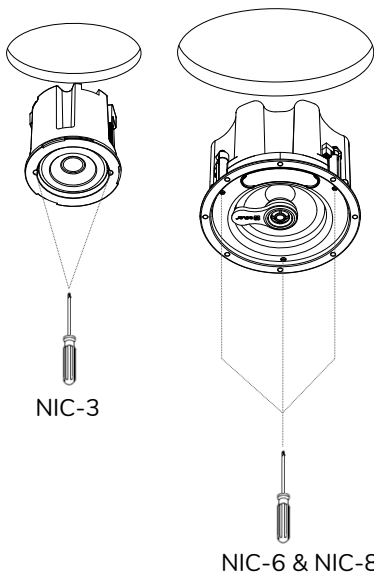

Place the speaker in the newly cut hole. Hold it in position with your hand and insert it carefully, ensuring that the three rotating fasteners are retracted.

Insert and tighten the screws (not supplied) into the front-accessible holes: 2 for NIC-3 and 3 for NIC-6 and NIC-8.

5

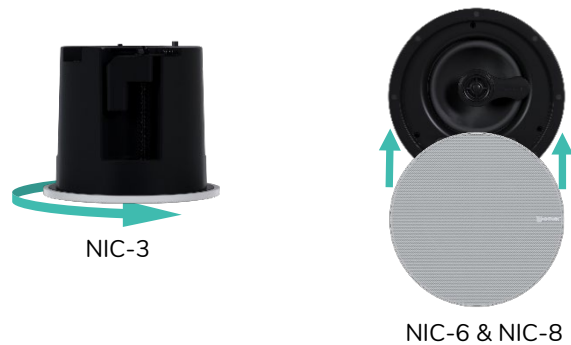

For the NIC-3, rotate the frameless grill to reattach it to the loudspeaker.

For the rest of the models, gently push the frameless magnetic protective grill until it is securely attached to the loudspeaker.



PRECAUTIONS

WARRANTY & ENVIRONMENT

PACKAGE CONTENTS

DESCRIPTION & FEATURES

CONNECTORS

LOCATION & ASSEMBLY

TECHNICAL DATA

6.2 Installation in suspended ceiling

NIC-3 can be installed in a suspended ceiling without the need for a tile bridge. The rest of the models require a tile bridge.

1

Assemble the mounting bridge bracket.

For NIC-6 and NIC-8, the corresponding mounting bridges NIC-SB6 and NIC-SB8, respectively, are sold separately.

2

suspended ceiling

Insert the assembled tile bridge into the suspended ceiling.

3

suspended ceiling

Fix the appropriate in-ceiling loudspeaker to the installed tile bridge in the suspended ceiling.

4

Use of a safety cable

In some regional building codes, the use of a secondary method for fastening loudspeakers to supporting structures is required to increase safety. Select a mounting location, a method, and components that comply with local building codes and regulations.

Ecler recommends using a safety wire **1** (not supplied) as a secondary fastening mechanism.

PRECAUTIONS
WARRANTY & ENVIRONMENT
PACKAGE CONTENTS
DESCRIPTION & FEATURES
CONNECTORS
LOCATION & ASSEMBLY
TECHNICAL DATA

7. TECHNICAL DATA

7.1 Technical Specifications

7.1.1 NIC-3

NIC-3

System		Effective frequency range ¹	112Hz-20kHz (-10dB)
		Coverage angle ²	172° conical
		Continuous Power handling ³	20W
		Program Power Handling ⁴	40W
		Peak Power Handling ⁵	80W
		On-axis Sensitivity ⁶	85dB
		Maximum SPL ⁷	95dB continuous / 101dB peak
		Power options	20W - 8Ω / 10W-100V-70V
		Recommended amplifier power	40W RMS
Transducers		Configuration	1-ways full range
		Low frequency driver	3" Woofer
		Nominal impedance	8Ω
Physical		Connection type	4-pin Euroblock connector, mounted on the rear of the baffle. Accepts cable sizes from 18 AWG (0.8 mm ²) to 14 AWG (2.5 mm ²)
		Installation options	In-ceiling / In-wall
		Enclosure material	ABS plastic
		Environmental	IP66
		Grill material	Aluminium
		Grill fixing system	Bayonet
		Mounting system	2 rotating tabs
		Operating temperature	Min: -30°C / -22°F Max: 65°C / 149°F
		Operating humidity	<85% HR
		Storage temperature	Min: -30°C / -22°F Max: 65°C / 149°F
		Storage humidity	<85% HR
		External diameter	113.5 mm / 4.47 in.
		Internal diameter	97 mm / 3.82 in.
		Recommended cut out diameter	100 mm / 3.94 in.
		Required depth	>120 mm / >4.72 in.
		Ceiling thickness	Min: 10 mm / 0.39 in. Max: 60 mm / 2.37 in.
		Included accessories	4 pin connector, 1 cutting template
		Optional accessories	NICRG3BK (Grille Black accessory RAL 9005)
		Finished colour	White (RAL 9003)
		Dimensions (WxHxD)	113.5 x 113.5 x 95 mm / 4.47 x 4.47 x 3.74 in.
		Weight	0.54 Kg / 1.19 lb
		Pieces per box	1
		Shipping dimensions (WxHxD)	155 x 145 x 145 mm. / 6.10 x 5.71 x 5.71 in.
		Shipping weight	0.86 Kg / 1.90 lb

⁽¹⁾ Measured frequency range within -10dB of the 1kHz octave band level, according to IEC 60268-5.

⁽²⁾ Beamwidth defined at -6 dB relative to the on-axis sound pressure level, using the maximum value within the 1kHz to 4kHz range.

⁽³⁾ RMS input power applied via IEC shaped band-limited pink noise for 2 hours, per AES2 power handling standard.

⁽⁴⁾ Conventionally 3 dB higher than the RMS measure, intended to represent real music signals.

⁽⁵⁾ Corresponds to the signal crests for the test described in (3).

⁽⁶⁾ Sound pressure level at 1m with 1W input at nominal impedance under half-space radiation conditions.

⁽⁷⁾ Calculated.



PRECAUTIONS

WARRANTY
&
ENVIRONMENT

PACKAGE
CONTENTS

DESCRIPTION
&
FEATURES

CONNECTORS

LOCATION
&
ASSEMBLY

TECHNICAL
DATA

7.1.2 NIC-6

NIC-6

System	
Effective frequency range ¹	66Hz-20kHz (-10dB)
Coverage angle ²	160° conical
Continuous Power handling ³	50W
Program Power Handling ⁴	100W
Peak Power Handling ⁵	200W
On-axis Sensitivity ⁶	88dB (1W/1m)
Maximum SPL ⁷	105dB continuous / 111 dB peak
Power options	100V: 12.5W / 25W / 50W 70V: 6.25W/ 12.5W / 25W
Recommended amplifier power	100W RMS
Transducers	
Configuration	2-ways full range
Low frequency driver	6,5" woofer
High frequency driver	1" Steerable Dome Tweeter
Nominal impedance	8Ω
Physical	
Connection type	4-pin Euroblock connector, mounted on the front of the baffle. Accepts cable sizes from 18 AWG (0.8 mm ²) to 14 AWG (2.5 mm ²)
Installation options	In-ceiling / In-wall
Enclosure material	ABS plastic
Environmental	IP66
Grill material	Iron
Grill fixing system	Magnets
Mounting system	3 rotating tabs
Operating temperature	Min: -30°C / -22°F Max: 65°C / 149°F
Operating humidity	<85% HR
Storage temperature	Min: -30°C / -22°F Max: 65°C / 149°F
Storage humidity	<85% HR
External diameter	267 mm / 10.51 in.
Internal diameter	229 mm / 9.02 in.
Recommended cut out diameter	232 mm / 9.13 in
Required depth	>190 mm / >7.48 in.
Ceiling thickness	Min: 10 mm / 0.39 in. Max: 60 mm / 2.37 in.
Included accessories	4-pin connector, 1 cutting template
Optional accessories	• NICRG6BK (Grille Black accessory RAL 9005). • NIC-TB6 (tile bridge)
Finished colour	White (RAL 9003)
Dimensions (WxHxD)	267 x 267 x 169 mm / 10.51 x 10.51 x 6.65 in.
Weight	3.12 Kg / 6.88 lb
Pieces per box	1
Shipping dimensions (WxHxD)	315 x 315 x 250 mm / 12.40 x 12.40 x 9.84 in.
Shipping weight	4.4 Kg / 9.7 lb

⁽¹⁾ Measured frequency range within -10dB of the 1kHz octave band level, according to IEC 60268-5.

⁽²⁾ Beamwidth defined at -6 dB relative to the on-axis sound pressure level, using the maximum value within the 1kHz to 4kHz range.

⁽³⁾ RMS input power applied via IEC shaped band-limited pink noise for 2 hours, per AES2 power handling standard.

⁽⁴⁾ Conventionally 3 dB higher than the RMS measure, intended to represent real music signals.

⁽⁵⁾ Corresponds to the signal crests for the test described in (3).

⁽⁶⁾ Sound pressure level at 1m with 1W input at nominal impedance under half-space radiation conditions.

⁽⁷⁾ Calculated.

	PRECAUTIONS
	WARRANTY & ENVIRONMENT
	PACKAGE CONTENTS
	DESCRIPTION & FEATURES
	CONNECTORS
	LOCATION & ASSEMBLY
	TECHNICAL DATA

7.1.3 NIC-8

NIC-8

System	
Effective frequency range ¹	59Hz-20kHz (-10dB)
Coverage angle ²	151° conical
Continuous Power handling ³	70W
Program Power Handling ⁴	140W
Peak Power Handling ⁵	280W
On-axis Sensitivity ⁶	88dB
Maximum SPL ⁷	106dB continuous / 112dB peak
Power options	100V: 8.75 / 17.5 / 35 / 70W 70V: 4.37 / 8.75 / 17.5 / 35W
Recommended amplifier power	140W RMS
Transducers	
Configuration	2-ways full range
Low frequency driver	8" Woofer
High frequency driver	1" Steerable Dome Tweeter
Nominal impedance	8Ω
Physical	
Connection type	4-pin Euroblock connector, mounted on the front of the baffle. Accepts cable sizes from 18 AWG (0.8 mm ²) to 14 AWG (2.5 mm ²)
Installation options	In-ceiling / In-wall
Enclosure material	ABS plastic
Environmental	IP66
Grill material	Iron
Grill fixing system	Magnets
Mounting system	3 rotating tabs
Operating temperature	Min: -30°C / -22°F Max: 65°C / 149°F
Operating humidity	<85% HR
Storage temperature	Min: -30°C / -22°F Max: 65°C / 149°F
Storage humidity	<85% HR
External diameter	314 mm / 12.36 in.
Internal diameter	276 mm / 10.87 in.
Recommended cut out diameter	278 mm / 10.94 in
Required depth	>200 mm / >7.87 in.
Ceiling thickness	Min: 10 mm / 0.39 in. Max: 60 mm / 2.37 in.
Included accessories	4-pin connector, 1 cutting template
Optional accessories	· NICRG8BK (Grille Black accessory RAL 9005). · NIC-TB8 (tile bridge)
Finished colour	White (RAL 9003)
Dimensions (WxHxD)	314 x 314 x 181 mm / 12.36 x 12.36 x 7.13 in.
Weight	4 Kg / 8.82 lb
Pieces per box	1
Shipping dimensions (WxHxD)	365 x 355 x 260 mm / 14.37 x 13.98 x 10.24 in.
Shipping weight	5.7 Kg / 12.57 lb

⁽¹⁾ Measured frequency range within -10dB of the 1kHz octave band level, according to IEC 60268-5.

⁽²⁾ Beamwidth defined at -6 dB relative to the on-axis sound pressure level, using the maximum value within the 1kHz to 4kHz range.

⁽³⁾ RMS input power applied via IEC shaped band-limited pink noise for 2 hours, per AES2 power handling standard.

⁽⁴⁾ Conventionally 3 dB higher than the RMS measure, intended to represent real music signals.

⁽⁵⁾ Corresponds to the signal crests for the test described in (3).

⁽⁶⁾ Sound pressure level at 1m with 1W input at nominal impedance under half-space radiation conditions.

⁽⁷⁾ Calculated.

	PRECAUTIONS
	WARRANTY & ENVIRONMENT
	PACKAGE CONTENTS
	DESCRIPTION & FEATURES
	CONNECTORS
	LOCATION & ASSEMBLY
	TECHNICAL DATA

7.2 Mechanical Diagram

7.2.1 NIC-3

All measurements are in mm.

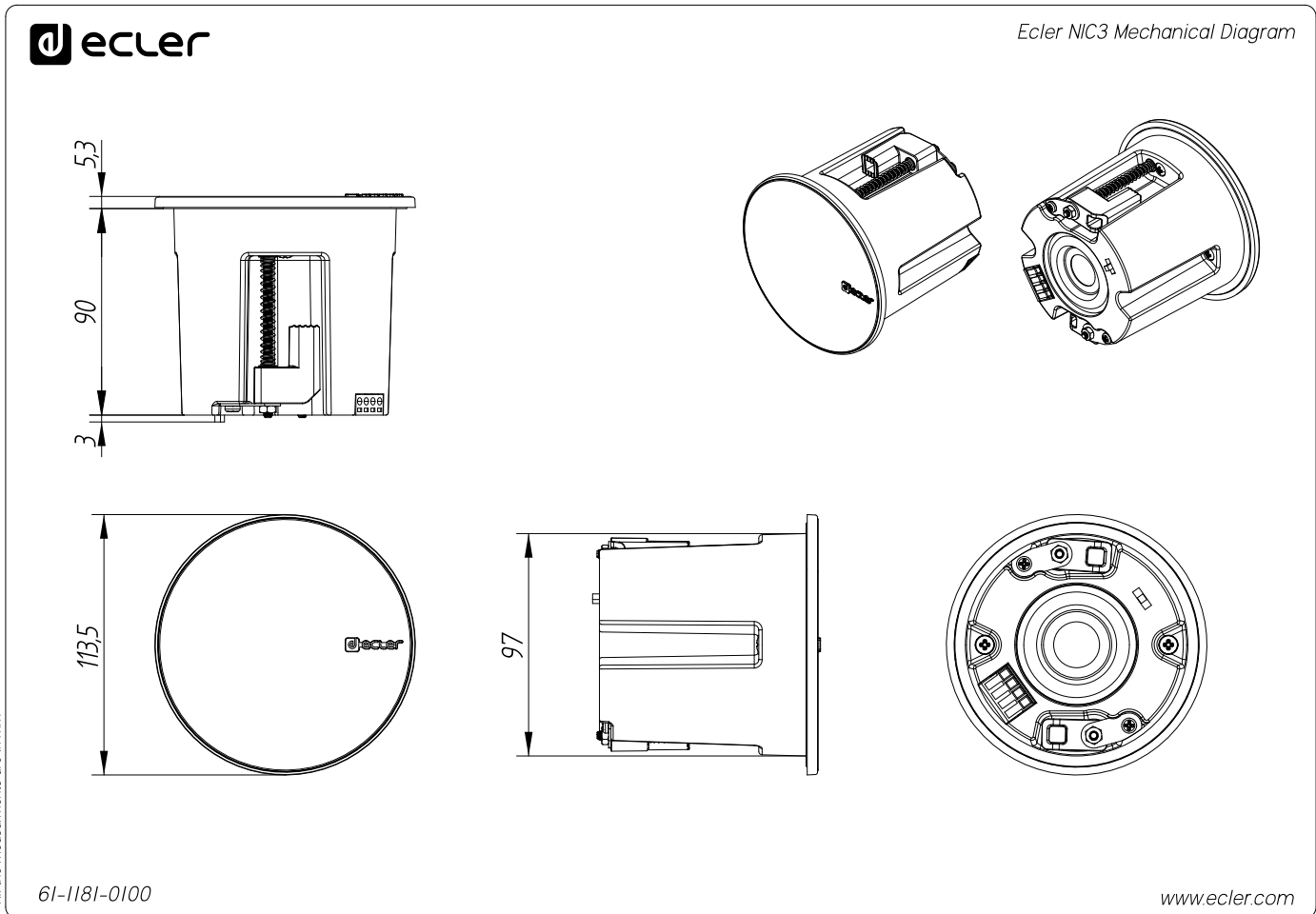

All the measurements are in mm

PRECAUTIONS
WARRANTY & ENVIRONMENT
PACKAGE CONTENTS
DESCRIPTION & FEATURES
CONNECTORS
LOCATION & ASSEMBLY
TECHNICAL DATA

7.2.2 NIC-6

All measurements are in mm.



Ecler NIC6 Mechanical Diagram

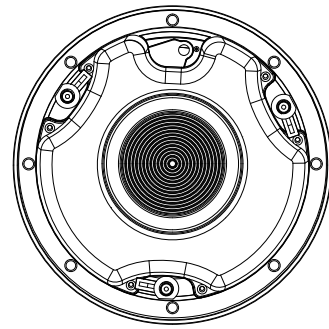
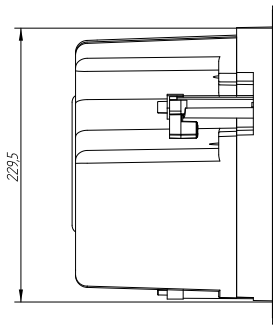
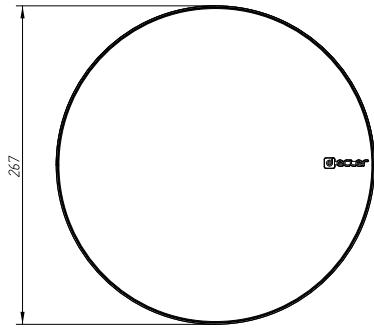
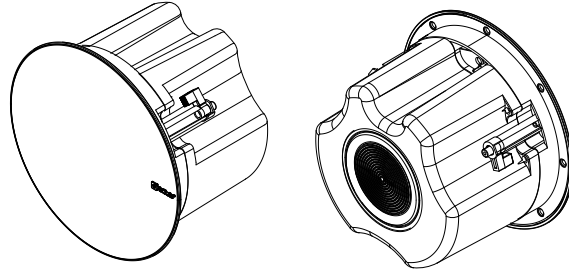
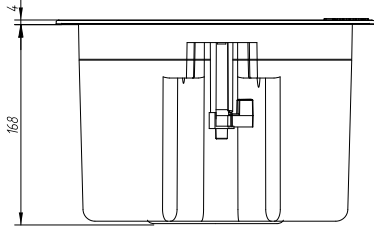

All the measurements are in mm.

6I-1182-0100

www.ecler.com



PRECAUTIONS

WARRANTY & ENVIRONMENT

PACKAGE CONTENTS

DESCRIPTION & FEATURES

CONNECTORS

LOCATION & ASSEMBLY

TECHNICAL DATA

7.2.3 NIC-8

All measurements are in mm.

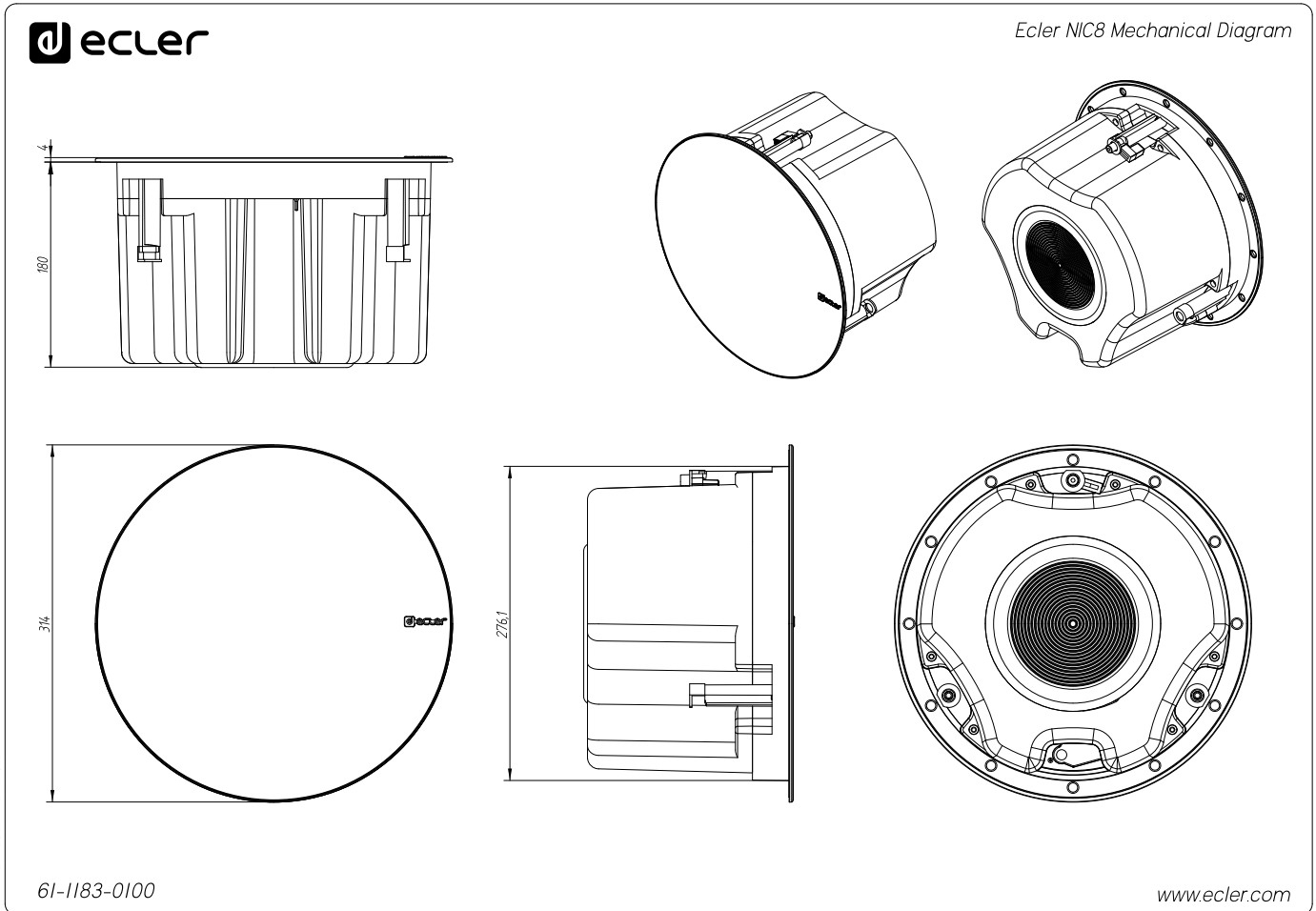

All the measurements are in mm

PRECAUTIONS
WARRANTY & ENVIRONMENT
PACKAGE CONTENTS
DESCRIPTION & FEATURES
CONNECTORS
LOCATION & ASSEMBLY
TECHNICAL DATA



PRECAUTIONS

WARRANTY
&
ENVIRONMENT

PACKAGE
CONTENTS

DESCRIPTION
&
FEATURES

CONNECTORS

LOCATION
&
ASSEMBLY

TECHNICAL
DATA