

WP22DN

REMOTE CONTROLS AND INTERFACES

DANTE™/AES67 digital audio wall panel interface



USER MANUAL

INDEX

1. IMPORTANT REMARK	3
2. IMPORTANT SAFETY INSTRUCTIONS	3
3. IMPORTANT NOTE	5
4. INTRODUCTION	5
4.1. Main features	5
5. INSTALLATION	6
5.1. Mounting the unit.....	6
5.2. WP22DN front panel controls	7
5.3. Installing an External Power Supply.....	10
6. POWER UP AND MANAGEMENT FROM DANTE CONTROLLER SOFTWARE	10
6.1 WP22DN Power Up.....	10
6.2 WP22DN network configuration and DANTE™/AES67 routing.....	11
7. NOTES:.....	13
8. FRONT PANEL	13
9. REAR PANEL	14
10. BLOCK DIAGRAM.....	15
11. ASSEMBLY DIAGRAM.....	16
12. TECHNICAL FEATURES	17
13. PACKAGE CONTENTS	18

1. IMPORTANT REMARK

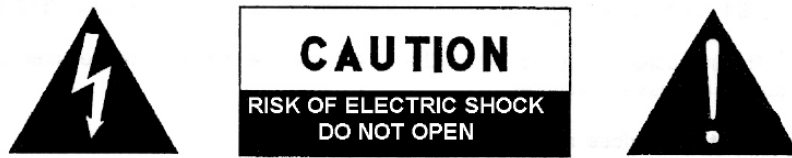

WARNING: SHOCK HAZARD - DO NOT OPEN
AVIS: RISQUE DE CHOC ÉLECTRIQUE - NE PAS OUVRIR



The lightning flash with arrowhead symbol, within an equilateral triangle, is intended to alert the user to the presence of uninsulated “dangerous voltage” within the product’s enclosure that may be of sufficient magnitude to constitute a risk of electric shock to persons.



The exclamation point within an equilateral triangle is intended to alert the user to the presence of important operating and maintenance (servicing) instructions in the literature accompanying the appliance.

WARNING (If applicable): The terminals marked with symbol of “” may be of sufficient magnitude to constitute a risk of electric shock. The external wiring connected to the terminals requires installation by an instructed person or the use of ready-made leads or cords.

WARNING: To prevent fire or shock hazard, do not expose this equipment to rain or moisture.

WARNING: An apparatus with Class I construction shall be connected to a mains socket-outlet with a protective earthing connection.

2. IMPORTANT SAFETY INSTRUCTIONS

1. Read these instructions.
2. Keep these instructions.
3. Heed all warnings.
4. Follow all instructions.
5. Do not use this apparatus near water.
6. Clean only with dry cloth.
7. Do not block any ventilation openings. Install in accordance with the manufacturer’s instructions.

8. Do not install near any heat sources such as radiators, heat registers, stoves, or other apparatus (including amplifiers) that produce heat.
9. Do not defeat the safety purpose of the polarized or grounding type plug. A polarized plug has two blades with one wider than the other. A grounding type plug has two blades and a third grounding prong. The wide blade or the third prong are provided for your safety. If the provided plug does not fit into your outlet, consult an electrician for replacement of the obsolete outlet.
10. Protect the power cord from being walked on or pinched particularly at the plugs, convenience receptacles, and at the point where they exit from the apparatus.
11. Only use attachments/accessories specified by the manufacturer.
12. Unplug the apparatus during lightening sorts or when unused for long periods of time.
13. Refer all servicing to qualified personnel. Servicing is required when the apparatus has been damaged in any way, such as power supply cord or plug is damaged, liquid has been spilled or objects have fallen into the apparatus, the apparatus has been exposed to rain or moisture, does not operate normally, or has been dropped.
14. Disconnecting from mains: Switching off the POWER switch all the functions and light indicators of the amplifier will be stopped, but fully disconnecting the device from mains is done unplugging the power cord from the mains input socket. For this reason, it always shall remain readily operable.
15. Equipment is connected to a socket-outlet with earthing connection by means of a power cord.
16. The marking information is located at the bottom of apparatus.
17. The apparatus shall not be exposed to dripping or splashing and that no objects filled with liquids, such as vases, shall be placed on apparatus.

NOTE: This equipment has been tested and found to comply with the limits for a Class A digital device, pursuant to part 15 of the FCC Rules. These limits are designed to provide reasonable protection against harmful interference when the equipment is operated in a commercial environment. This equipment generates, uses, and can radiate radio frequency energy and, if not installed and used in accordance with the instruction manual, may cause harmful interference to radio communications. Operation of this equipment in a residential area is likely to cause harmful interference in which case the user will be required to correct the interference at his own expense.



WARNING: This product must not be discarded, under any circumstance, as unsorted urban waste. Take to the nearest electrical and electronic waste treatment centre.

NEEC AUDIO BARCELONA, S.L. accepts no liability for any damage that may be caused to people, animal or objects due to failure to comply with the warnings above.

3. IMPORTANT NOTE

Thank you for choosing our **DANTE™/AES67 digital audio wall panel audio interface WP22DN**.

It is **VERY IMPORTANT** to carefully read this manual and to fully understand its contents before any connection in order to maximize your use and get the best performance from this equipment.

To ensure optimal operation of this device, we strongly recommend that its maintenance be carried out by our authorized Technical Services.

All ECLER products are covered by warranty, please refer to www.ecler.com or the warranty card included with this product for the period of validity and conditions.

4. INTRODUCTION

WP22DN is a wall panel interface with DANTE™/AES67 digital audio transport protocols compatibility.

It features 2 audio MIC/LINE Combo connector inputs in its frontal panel and 2 DANTE™/AES67 conversion channels either directly or by the sum of the analogue inputs channels (stereo to mono conversion). Also, it features 2 analogue outputs with duplicated connectors in XLR format for the front panel and Euroblock on the rear panel, both linked to 2 DANTE™/AES67 channels coming from the local network. It supports PoE supply or local power supply.

4.1. Main features

- DANTE™/AES67 compatible audio interface wall panel
- 2 balanced analog inputs, MIC/LINE level (4 gain taps selector), with Combo connector
- Conversion of 2 analog channels to 2 DANTE™/AES67 channels, directly taking the 2 input channels or combining them (IN1 + IN2 mix)
- 2 balanced analogue outputs, with XLR connector on the front panel and Euroblock connector on the rear panel. The outputs come from the conversion of the 2 DANTE™/AES67 channels received in the unit
- Ethernet communication interface, RJ45 connector
- PoE power or by local power supply
- Phantom Power available for the analogue inputs, 48VDC, 5 mA max.

- Double gang size, compatible with Ecler double gang surface mount installation box (WPa2SMBOX, supplied by default with each unit) and with Ecler double gang flush mount installation box (WPa2FMBOX, optional)
- Double set of front panel plates: one with access to the inputs' gain selector, and the other one without access to the gain selector

5. INSTALLATION

The installation of the WP22DN unit comprises the following steps.

5.1. Mounting the unit

1. Remove the front panel covers, held in place by magnets. You can use the magnet provided as a tool, by making contact in the upper right corner of the cover and gently pulling on it.
2. Connect the RJ-45 connector on the CAT5 or higher cable that will connect the unit to the local area network. If necessary (see below section [Installing an External Power Supply](#)) - connect an external power.
3. If required, connect the analogue audio outputs at the back side of the unit (equipped with Euroblock terminals) to the desired audio device. These 2 outputs are an exact copy of the 2 outputs available with XLR connectors at the front panel.
4. Screw the device to the surface mount box or flush mount box.
5. Mount the desired set of front panel covers (with or without access to the inputs' gain trimmers), held in place by magnets.

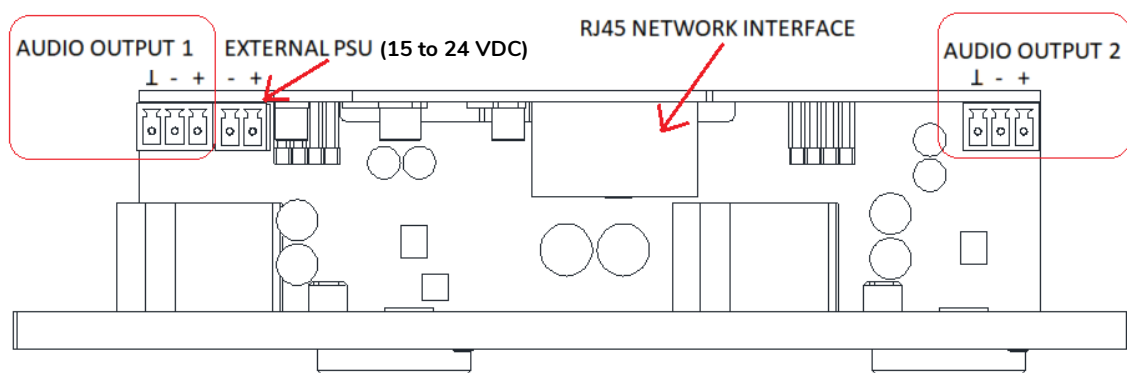

WP22DN top view

5.2. WP22DN front panel controls

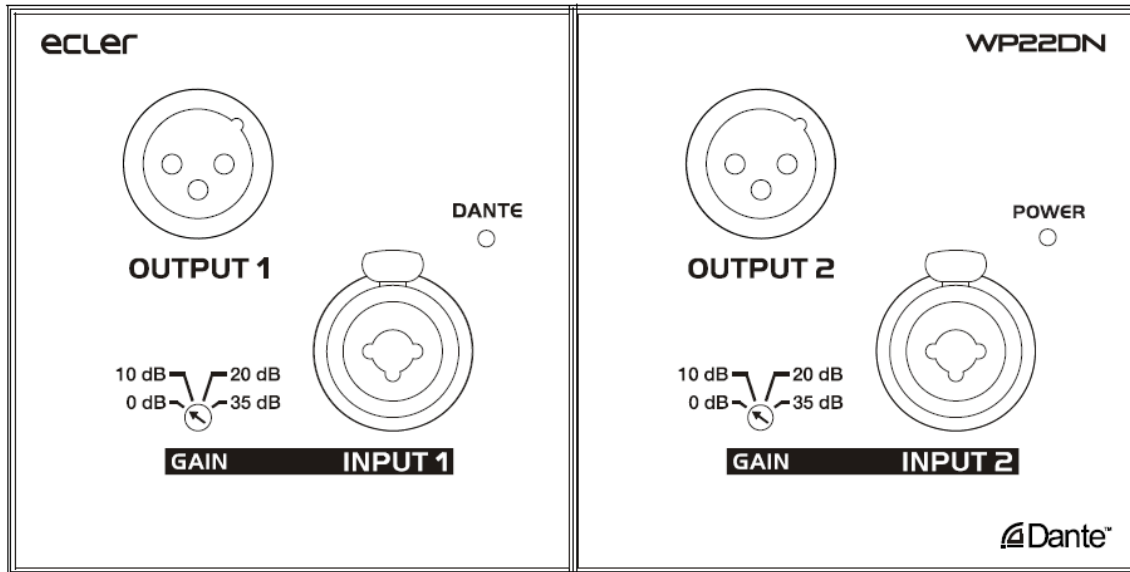

WP22DN front panel view

Behind the right front panel plate (INPUT2 / OUTPUT 2) there's a 3 x DIP Switch selector set. It is used to define the contents of DANTE™/AES67 output channels 1 and 2 (coming from straight analogue inputs or a combination of them both) and the activation of the Phantom Power for the analogue input channels.

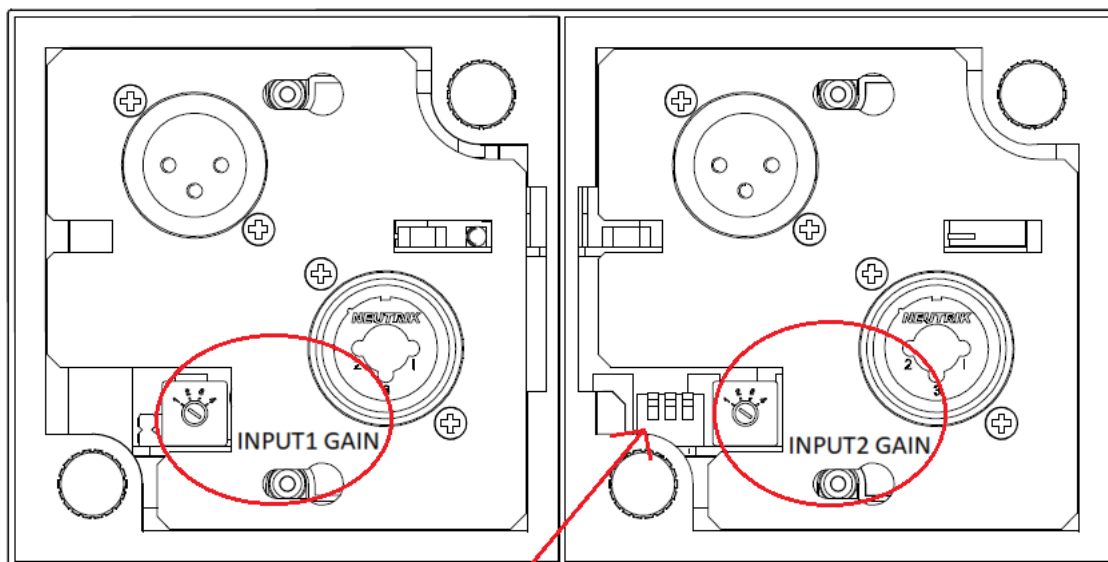

DIP SWITCHES 1, 2, 3 (left to right)

WP22DN front panel view with front plates removed

DIP Switch 1 (left one)	DIP Switch 2 (centre one)	DIP Switch 3 (right one)
OFF (up position): Dante Channel 1 = analogue IN1	OFF (up position): Phantom Power for analogue IN1 and IN2 = OFF	OFF (up position): Dante Channel 2 = analogue IN2
ON (down position): Dante Channel 1 = analogue IN1 + IN2	ON (down position): Phantom Power for analogue IN1 and IN2 = ON	ON (down position): Dante Channel 2 = analogue IN2 + IN1

DIP Switches configuration table

Additionally, each analogue input has its own gain control, with 4 taps: 0 / 10 / 20 / 35dB, as marked in the front panel plates which have that access enabled for the adjustment using a screwdriver.

Note: a DANTE™/AES67 receiver unit is required to check, by means of vumeters, the proper adjustment of these input gains and resulting levels, once the signals have been converted to DANTE™/AES67 by the WP22DN unit and received by this DANTE™/AES67 receiver unit. In the next example a MIMO4040DN unit is receiving two DANTE™/AES67 channel coming from a WP22DN unit:

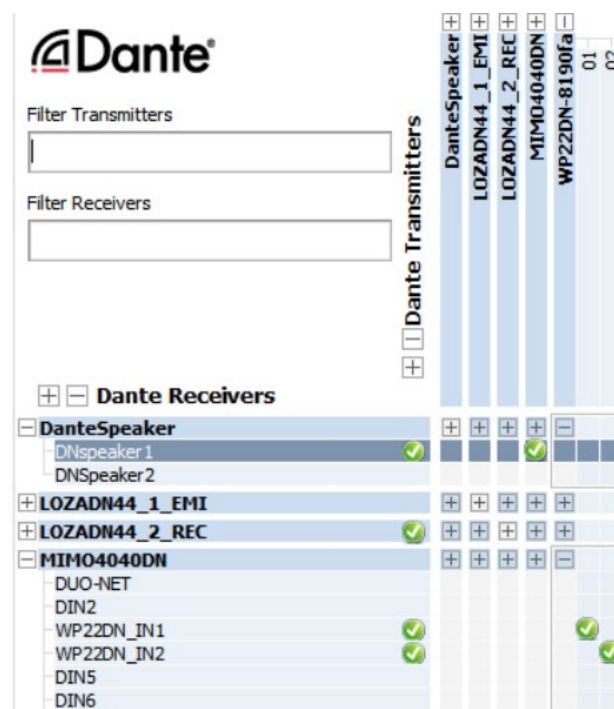

It's then possible to monitor their levels in the MIMO4040DN reception unit:

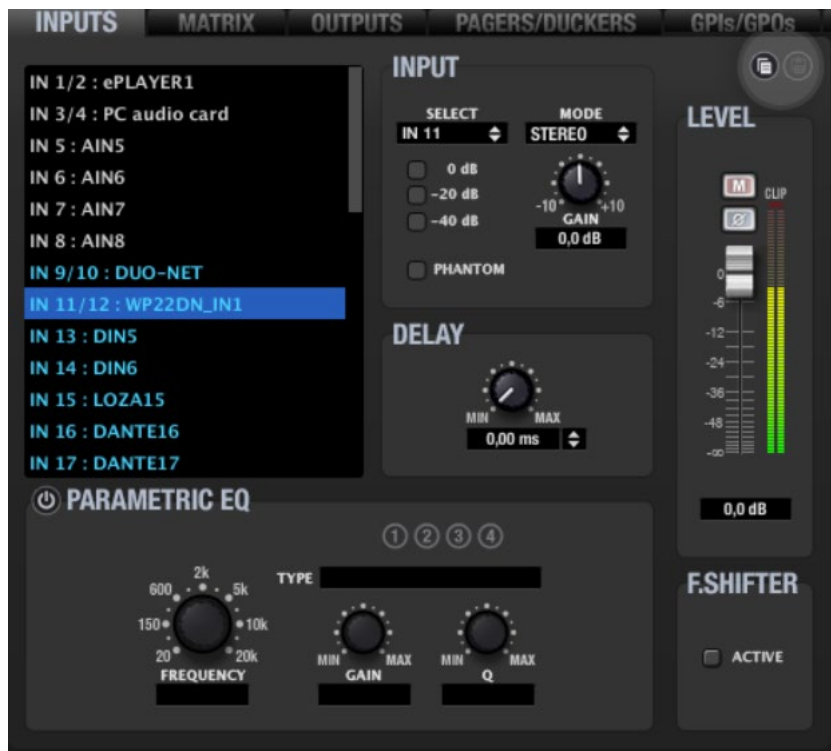

5.3. Installing an External Power Supply

In case of not having a PoE type power received in the WP22DN panel directly from the connection port of the network switch to which it is connected, it is possible to power the panel through an optional external power supply, model WP-PSU or WP24-PSU, with stripped wires connected to the Euroblock + and - terminals shown in 5.1. **Mounting the unit.**



WP-PSU power supply

6. POWER UP AND MANAGEMENT FROM DANTE CONTROLLER SOFTWARE

6.1 WP22DN Power Up

When the unit is connected to the DANTE™/AES67 network and supplied with PoE or external DC supply, the front panel LED indicators will show the following information:

POWER LED: will light up in green meanwhile the unit is powered

DANTE LED: will light with the following coded information:

- **RED (fixed):** during the boot up process
- **AMBER (fixed):** during the PTP (Precision Time Protocol) network time synchronization
- **GREEN (fixed):** when the unit has been set up as a D DANTE™/AES67 Slave
- **GREEN (blinking):** when the unit has been set up as a DANTE™/AES67 Master

6.2 WP22DN network configuration and DANTE™/AES67 routing

In order to configure WP22DN network parameters and DANTE™/AES67 channels transmission and reception, Audinate's application Dante Controller must be used. For extended information, please refer to the developer's documentation:

www.audinate.com/products/software/dante-controller?lang=es

WP22DN comes from factory with DHCP service activated, meaning this that the unit will automatically take a dynamic IP address served by a DHCP server in the local area network where it is connected to, in case it exists. However, specific static network parameters can be configured using Dante Controller, accessing to the window shown in this example:

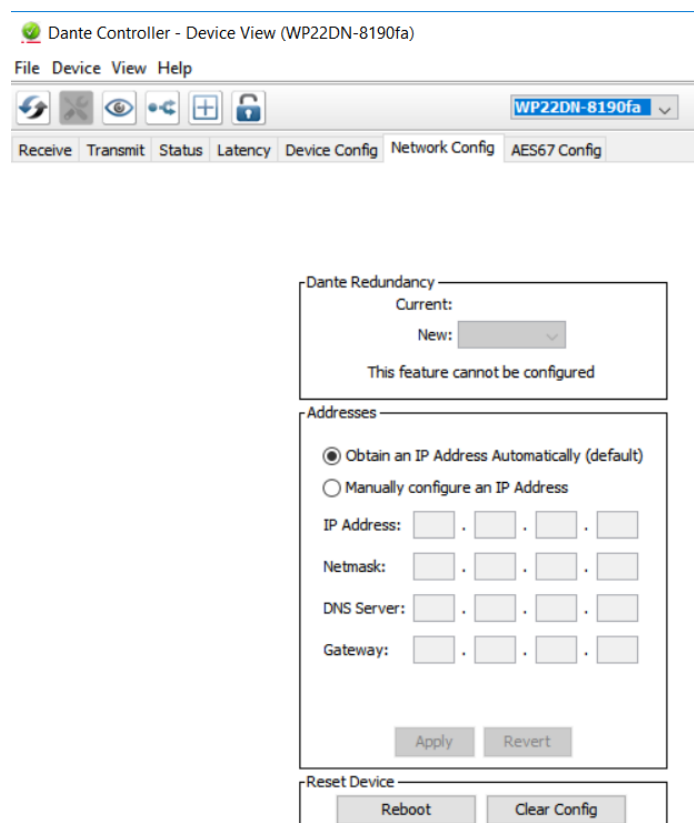

The screenshot shows the Dante Controller interface for device WP22DN-8190fa. The 'Device View' tab is active, and the 'AES67 Config' sub-tab is selected. The configuration area is divided into three sections:

- Dante Redundancy:** Includes 'Current:' and 'New:' dropdown menus. A message below states 'This feature cannot be configured'.
- Addresses:** Contains radio buttons for 'Obtain an IP Address Automatically (default)' (selected) and 'Manually configure an IP Address'. Below are input fields for IP Address, Netmask, DNS Server, and Gateway, each with four digit boxes separated by dots.
- Reset Device:** Contains 'Reboot' and 'Clear Config' buttons.

The unit's default name (label shown in Dante Controller), from factory, is always WP22DN-nnnnnn, where “nnnnnn” matches the 6 last digits from the MAC address of each device. Anyway, this name can be renamed accessing to this window:

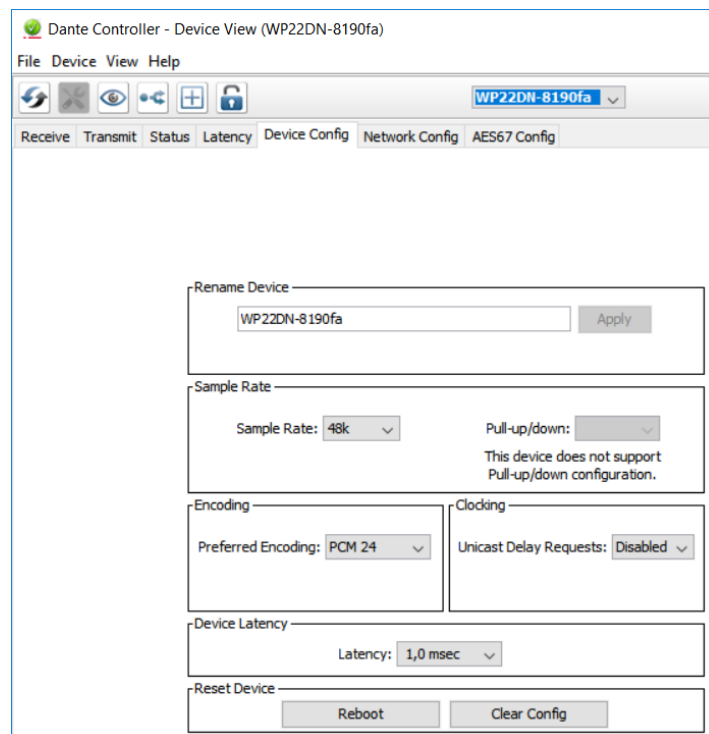

The routing for DANTE™/AES67 channel transmitters and receivers can be defined in the routing window, where all the devices with Dante capabilities detected in the network will as well appear:

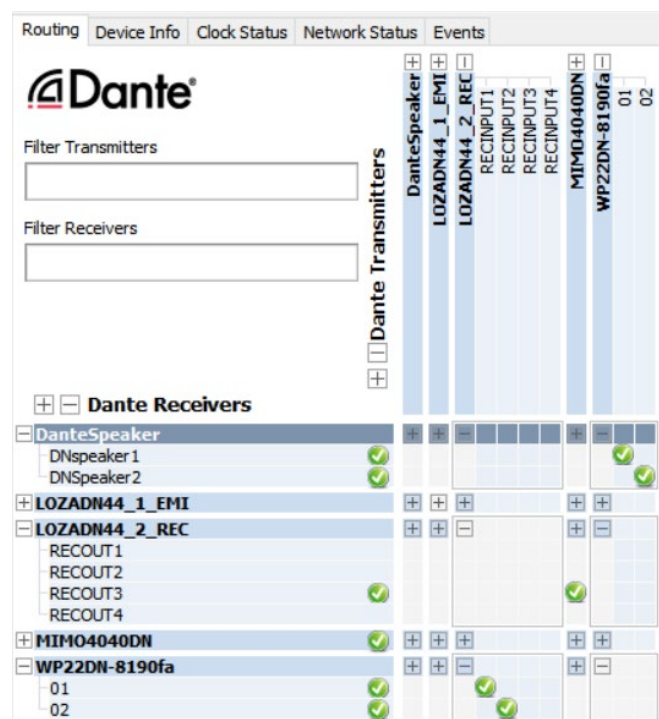

7. NOTES:

Check that all WP22DN, MIMO4040DN, WPNET, etc. units in a project are working with the latest firmware versions available.

At www.ecler.com an EclerNet software firmware package is always available, including the latest official versions of EclerNet Manager firmware and software.

8. FRONT PANEL

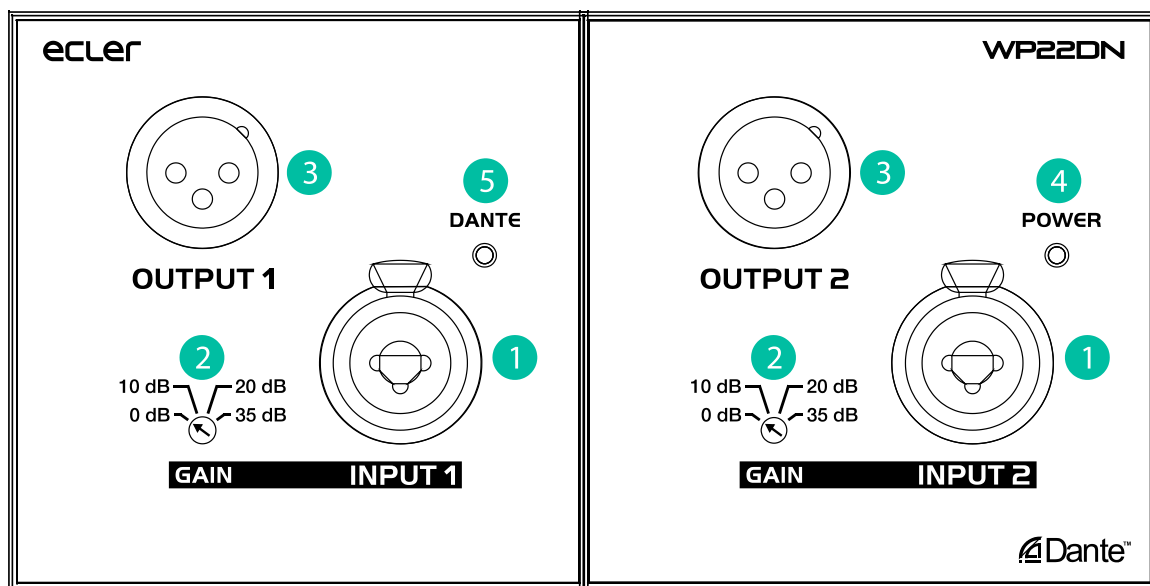

1. INPUT 1 and 2 Combo connectors (analogue inputs)
2. INPUT 1 and 2 GAIN selectors (analogue inputs)
3. OUTPUT 1 and 2 XLRM connectors (analogue outputs)
4. POWER LED
5. DANTE LED

9. REAR PANEL

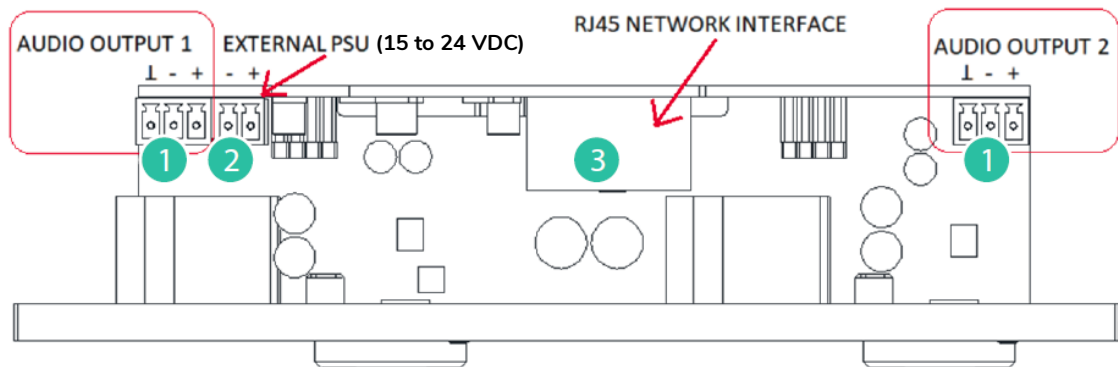

1. OUTPUT 1 and 2 Euroblock connectors (analogue outputs)
2. External PSU connector (15 to 24 VDC compatible)
3. RJ45 network DANTE™/AES67 interface

10. BLOCK DIAGRAM

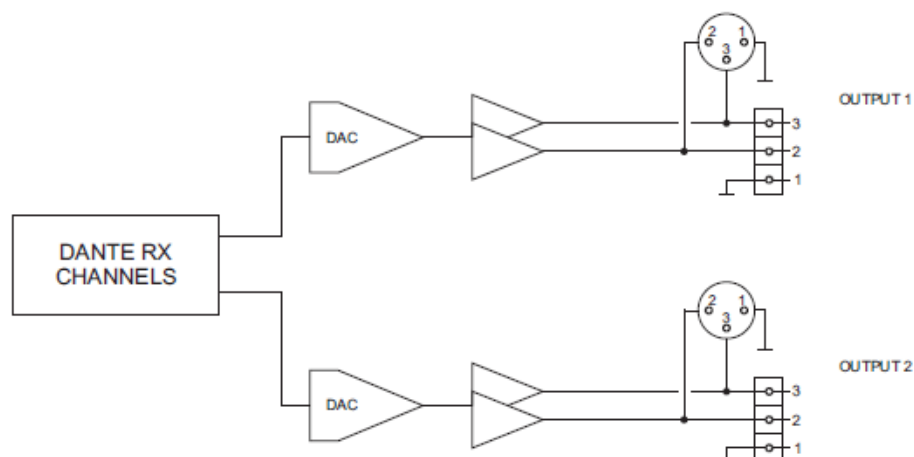
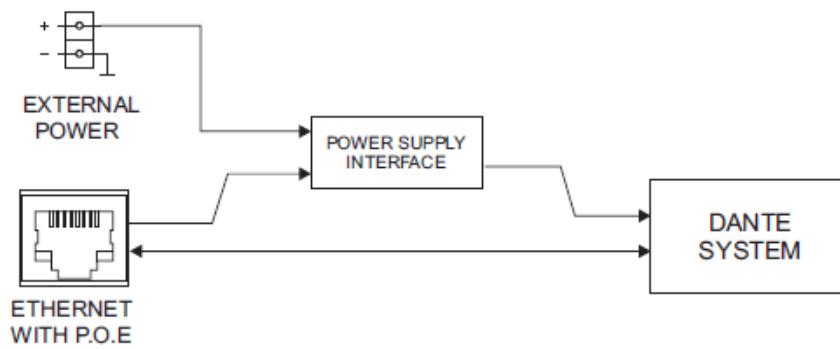
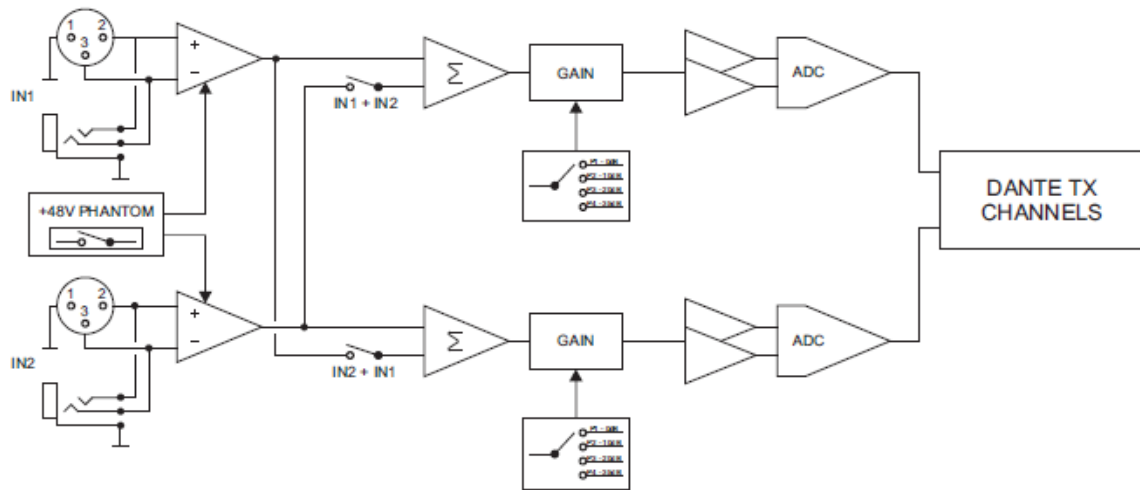

11. ASSEMBLY DIAGRAM

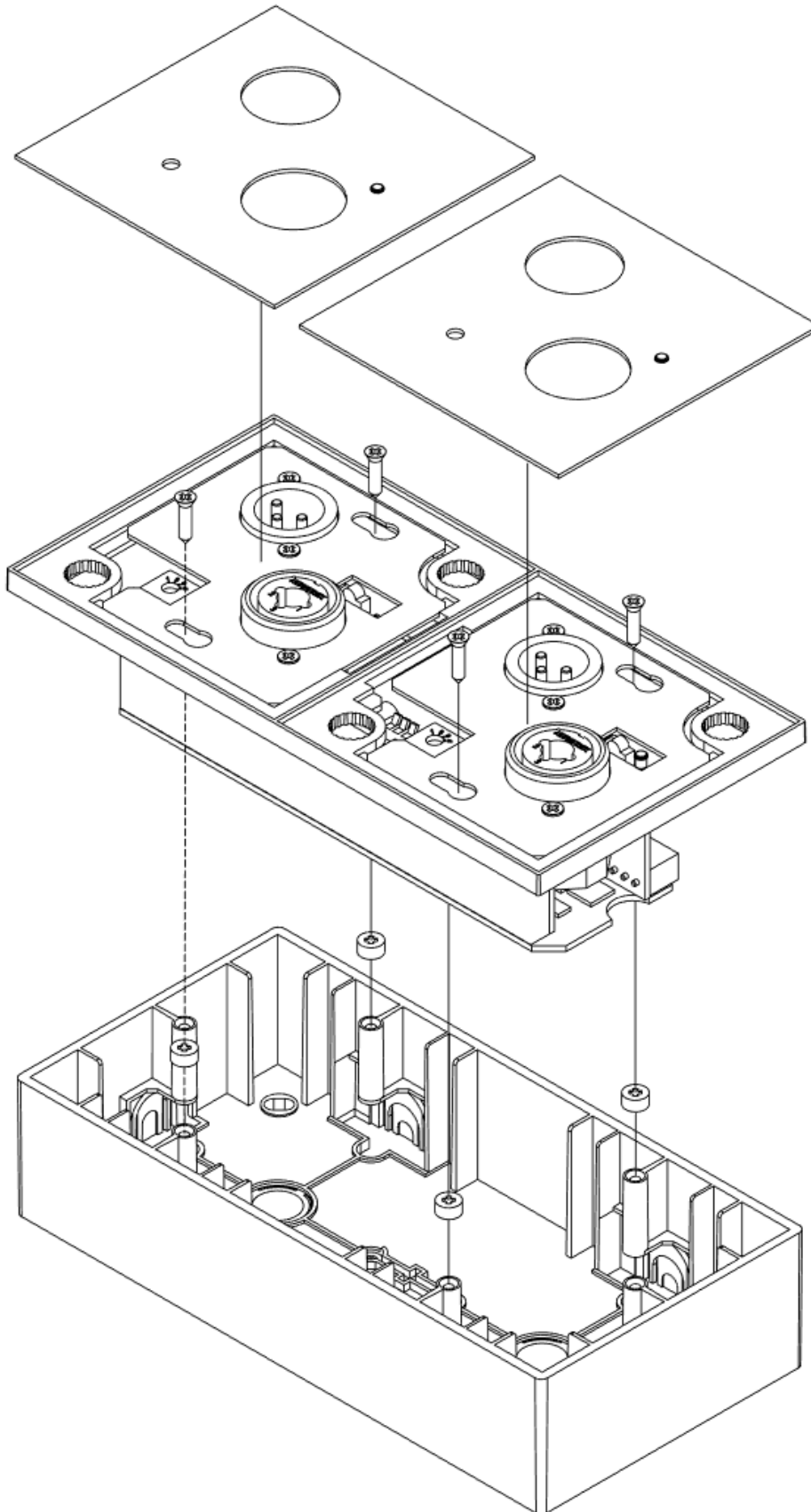

12. TECHNICAL FEATURES

WP22DN	
Analogue inputs	
Input channels	2 x analog, balanced
Connectors	2 x XLR F + jack Combo
Max Input Level	+10dBV / +12dBu @ 0dB Gain
Gain settings	0 / 10 / 20 / 35dB
Input Impedance	Balanced > 4kΩ
CMRR 20Hz- 20kHz	65dB typ.
THD+Noise @ 1kHz, 0dBV Gain	<0.004%
Phantom power	+48VDC, 5mA max. ON / OFF by DIP SWITCH
Analogue outputs	
Output channels	2 analog, balanced, line level
Connectors	2 XLR M External, 2 Euroblock Internal
Max Output Level	+10dBV / +12dBu @ 0dB Gain
Frequency response (-3dB)	5Hz to 24kHz
Flatness	better than ±0.1dB
THD+Noise @ 1kHz	<0.004%
Output Noise floor FFT (20Hz - 20kHz)	better than 110dB
AD/DA converters	
Resolution	24bit AKM 48kHz
Dynamic Range	ADC 110dB
	DAC 115dB
Latency (fs = 48 kHz)	ADC 0,81ms
	DAC 0,56ms
Dante™ / AES67 audio interface	
Dante™ / AES67 Network Tx / Rx channels	2 / 2 (2/2 flows)
Latency	1 / 2 / 5 ms (selectable)
Connector	1 x RJ45
Cable length between devices	100m CAT5e/CAT6
DC supply	
Poe Power supply	PoE: class 0 802.3af Poe PD compliant
External Power supply	15 - 24VDC
Power consumption	from PoE 60mA / 2.8W, from Ext power 2.7W
Accessories included	
Mounting systems	Surface mount installation box WPa2SMBOX
Mechanical	
Finished colour	White (RAL 9016)
Dimensions	170x85x40mm / 6.7" x 3.3" x 1.6"
Weight	0,4 kg. / 0.9 lb.

13. PACKAGE CONTENTS

- One WP22DN unit
- Double frame for mounting on Ecler double electrical boxes
- Double set of front panel plates: with and without access to analogue inputs' gain
- Screws for fixing to surface or flush double electrical boxes
- Magnet for front plates removal
- Ecler Double gang surface mount box
- Euroblock aerial connectors
- Quick User Guide
- Warranty Card

All product characteristics are subject to variation due to production tolerances. **NEEC AUDIO BARCELONA S.L.** reserves the right to make changes or improvements in the design or manufacturing that may affect these product specifications.

For technical queries contact your supplier, distributor or complete the contact form on our website, in [Support / Technical requests](#).

Motors, 166-168 08038 Barcelona - Spain - (+34) 932238403 | information@ecler.com | www.ecler.com