

DARA-4B900

AMPLIFIERS

Networkable Amplifiers



PRODUCT OVERVIEW

DARA-4B900 is a high-performance, network-enabled Class D power amplifier developed for professional audio installations requiring flexibility, efficiency, and dependable system control. Delivering up to $4 \times 900 \text{ W RMS @ } 4 \Omega$, it supports both low- and high-impedance loudspeaker systems ($70 \text{ V} / 100 \text{ V}$) as well as Bridge mode, configurable by pairs of channels to adapt to a wide range of installation needs.

Equipped with an integrated DSP with internal matrix and dual Ethernet ports with an embedded switch, the DARA-4B900 enables precise audio management and seamless integration into scalable networked systems. Full compatibility with the PULSO Series allows remote control and monitoring via mobile apps or web interface, making it an efficient and reliable solution for modern fixed installations across multiple applications.

KEY FEATURES

- 4-channel Class D power amplifier with high-efficiency design.
- $4 \times 900 \text{ W RMS @ } 4 \Omega$ output power.
- Supports 2Ω , 4Ω , 8Ω , 70 V , 100 V and Bridge mode (configurable by channel pairs).
- 4 analogue balanced inputs with internal 4×4 digital matrix.
- Integrated DSP for advanced audio processing and system optimization.
- Ecler loudspeaker EQ presets included.
- Dual Ethernet ports with integrated switch for network daisy-chaining.
- Remote control and configuration via PULSO Series (Android / iOS App).
- Embedded web interface for setup, monitoring, and control.
- Auto Standby function for energy savings.
- Comprehensive protection systems (thermal, overload, short-circuit, clip).
- Safety Euroblock connections for secure wiring.
- Software-lockable front panel to prevent unauthorized access.

APPLICATIONS

- Retail
- Hospitality
- Education
- Corporate
- Leisure
- Sport & Wellness

ACCESSORIES & COMPATIBLE PRODUCTS

•PULSO Series

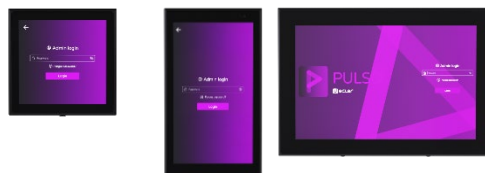

TECHNICAL SPECIFICATIONS

DARA-4B900

CHANNELS	
Number of Outputs channels	4
Output connection type	2-pin Euroblock. Pitch: 5,08 mm
Output configuration	2 Ω , 4 Ω , 8 Ω , 100V, 70V and 4/8 Ω in Bridge Mode
Number of Inputs channels	4
Input connection type	3-pin Euroblock, balanced, pitch 3,5 mm
Input configuration	Digital Matrix 4 In x 4 Out
OUTPUT POWER All channels driven @1kHz @CF9dB @ 1%THD	
Max output power @ 8 Ω	550 W
Max output power @ 4 Ω	900 W
Max output power @ 2 Ω	1600 W
Max output power @ 4 Ω bridge mode	3200 W
Max output power @ 8 Ω bridge mode	1600 W
Max output power @ 100V	900 W
Max output power @ 70V	900 W
OUTPUT POWER Single channel driven @1kHz @CF9dB @ 1%THD	
Max output power @ 8 Ω	550 W
Max output power @ 4 Ω	900 W
Max output power @ 2 Ω	1600 W
Max output power @ 4 Ω bridge mode	3200 W
Max output power @ 8 Ω bridge mode	1600 W
Max output power @ 100V	900 W
Max output power @ 70V	900 W
SIGNAL	
Voltage gain	36dB
Input sensitivity	0 dBV 2,21 dBu 1 Vrms
Input impedance	20k Ω balanced
Max input level	+20,8dBV 23 dBu
Frequency response	15Hz - 22kHz (-3dB, 1W any load)
THD + Noise	<0,1% (@1kHz, from 0,1W to Full Power)
SNR	97,8 dBa
Crosstalk	>90 dB (@1kHz)
CMRR	> 52 Typ (from 20Hz to 20kHz)
ELECTRICAL	
Power supply	Universal, regulated SMPS with PFC
AC mains requirement	100-240 V @ 50-60Hz (\pm 10%)
Power factor correction	> 0,96
AC mains connector	IEC C14 inlet
POWER & HEAT @230VAC	
1/4 POWER, @ 4 Ω (all channels driven)	
Power	1236 W 1300 VA
Current Draw	5,7 Arms
Thermal Loss	289 kcal/h 1146 BTU/h

1/8 POWER, @ 4Ω (all channels driven)	
Power	692,5 W 744 VA
Current Draw	3,25 Arms
Thermal Loss	208,6 kcal/h 827,7 BTU/h
IDLE (all channels driven)	
Power	100 W 163 VA
Current Draw	0,71 Arms
Thermal Loss	86 kcal/h 341,3 BTU/h
SLEEP MODE (all channels driven)	
Power	4,8 W 81 VA
Current Draw	0,35
Thermal Loss	4,1 kcal/h 16,4 BTU/h

POWER & HEAT @120VAC

1/4 POWER, @ 4Ω (all channels driven)	
Power	1321 W 1337 VA
Current Draw	11,45 Arms
Thermal Loss	362,1 kcal/h 1436,9 BTU/h
1/8 POWER, @ 4Ω (all channels driven)	
Power	725 W 739 VA
Current Draw	6,27 Arms
Thermal Loss	236,5 kcal/h 938,6 BTU/h
IDLE (all channels driven)	
Power	97,6 W 118 VA
Current Draw	0,97 Arms
Thermal Loss	83 kcal/h 329,4 BTU/h
SLEEP MODE (all channels driven)	
Power	4,2 W 27,3 VA
Current Draw	0,23 Arms
Thermal Loss	3,6 kcal/h 14,3 BTU/h

TECHNOLOGIES

Amplification technology	Class D
Energy saving	Auto standby function selectable
Efficiency	74% (1/4 POWER, @ 4Ω)
Cooling	2 fans
Maximum fan noise	57 dBA

DSP	
AD converters	24 Bit Tandem™ @ 48 kHz 105 dB-A Dynamic Range - 0.0018% THD+N
DA converters	24 Bit Tandem™ @ 48 kHz 120 dB Dynamic Range - 0.001% THD+N
Sample rate converter	24 bits @ 48 kHz
Internal precision	32 bits floating point
Latency	1,5 ms
Memory/Presets	15 amplifiers presets 40 Speakers presets (22 Ecler presets + 18 Custom presets)
Delay	20 ms (input) + 300 ms (output) for time alignment
Equalizer	Custom FIR, Parametric IIR: Peaking, Low Shelf, High Shelf, AllPass 1st, AllPass 2nd, General Low, General High, Butterworth Low, Butterworth High, Bessel Low, Bessel High
Limiters	RMS and Peak voltage limiter
Digital processing	32 bits
Inputs processing	Delay, Parametric and Graphic EQ, Compressor
Outputs processing	Delay, Parametric and Graphic EQ, Polarity, Compressor, FIR filters, RMS and Peak Limiter
Others	Presets management, Panels and Users, Internal matrix, Linking and Stereo options, Selectable Auto-standby, Panel Operating Range, Knobs and GPI Matrix, Custom and Ecler speakers settings, Network Parameters, Finder, Remote control and configuration via PULSO Series (Android / iOS App)
PROTECTIONS	
AC protection	Yes
DC protection	Yes
HF protection	Yes
Short-circuit protection	Yes
Clip limiter	Yes
Thermal protection	Yes
REMOTE CONTROL CONNECTIONS	
GPIs	x4 GPIs (0-10V)
External MUTE	Yes, contact
LOCAL CONTROL	
Attenuators	Assignable front panel knobs
Output mode settings	Back panel Dipswitch by pairs of channels
RUN/SLEEP mode	Auto standby function Forced standby (Settings by embedded web application)
Power ON/OFF	Front panel switch
SETTINGS	
Attenuators	Assignable front panel knobs
Output settings	2Ω/4Ω/8Ω/70V/100V/Bridge Mode output selection by pair of channels
Auto standby function	Settings by embedded web application
Auto standby threshold	-40dB
Auto standby time	90 seconds
Power ON/OFF	Front panel switch

CONNECTIVITY	
Ethernet	Ethernet Base-Tx 100Mb CAT5 up to 100m Secondary RJ-45 port for Daisy-Chaining
Programming and control	Embedded web application
MONITORING	
Signal Present	SIGNAL LED (Green) per channel
Clipping	CLIP LED (Red) per channel
Protect	TH/PROT LED (Red) per channel
Standby	STANDBY (Orange) per channel
Mute	MUTE LED (White) per channel
Limit	TH/PROT LED (Red)
Thermal	TH/PROT LED (Red) per channel
Data	DATA LED (White) per unit
On	ON LED (Green) per unit
DIGITAL ENGINE	
Processor	32 bits
AUDIO CONVERTERS	
Sampling rate	48 kHz
Resolution	24 bits
Dynamic range	112 dB
PHYSICAL	
Operating temperature	-20° to 40° C -4° to 104° F
Operating humidity	10-90% RH, non-condensing
Storage temperature	-40° to 70° C -40° to 158° F
Storage humidity	10-95% RH, non-condensing
Installation options	Rack 19" installation & desktop
Included accessories	EU power cord, UK,US and CN power cord adapters, IEC Power Cord, Remote Volume connector (GPI), External Mute connector x4 Euroblock 3-pin connectors (Inputs), x2 Euroblock 4-pin connectors (Outputs), Warranty Card, Rear Rack Kit, 3M rubber foot (4pcs)
Dimensions (WxHxD)	482.6 x 44 x 414 mm / 19 x 1.73 x 16.30 in.
Weight	7.65 kg / 16.87 lb
Shipping dimensions (WxHxD)	590 x 80 x 590 mm / 23.23 x 3.15 x 23.23 in.
Shipping weight	10.74 kg / 23.68 lb

MECHANICAL DIAGRAM

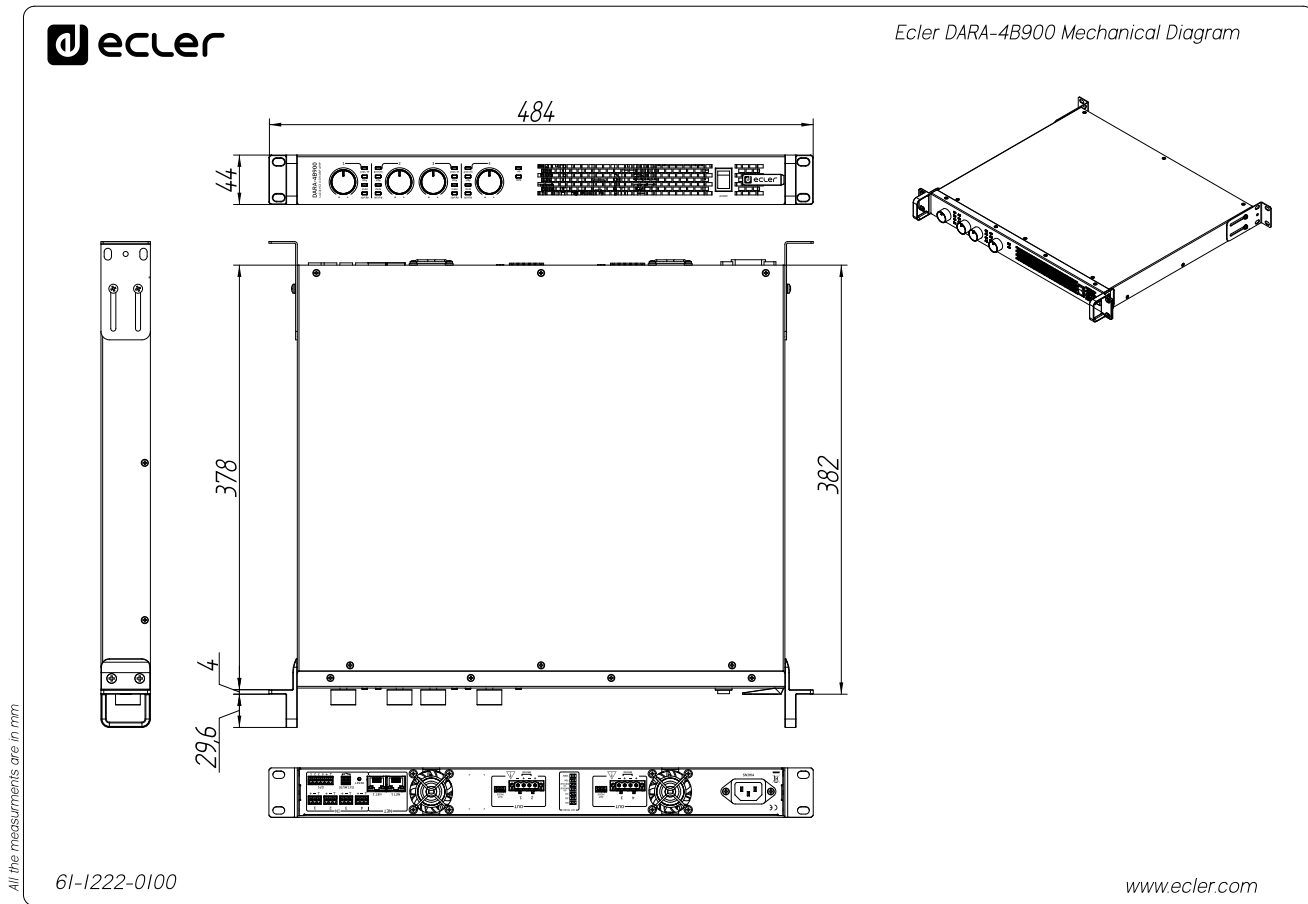

All the measurements are in mm

61-1222-0100

www.ecler.com