

# VIVO-X8D8 / VIVO-X8 BIO-X8G / BIO-X8

DIGITAL PROCESSORS & MATRIXES  
EclerPLEX Matrix  
EclerPLEX Expansion Interface



## USER MANUAL



- PRECAUTIONS
- WARRANTY & ENVIRONMENT
- PACKAGE CONTENTS
- DESCRIPTION & FEATURES
- INSTALL & CONNECT
- START-UP & OPERATION
- PANEL FUNCTIONS
- TECHNICAL DATA

# TABLE OF CONTENTS

<b>1. PRECAUTIONS.....</b>	<b>4</b>
1.1 Important Notice.....	4
1.2 Key Safety Directions.....	5
1.3 Cleaning Directions.....	5
<b>2. WARRANTY &amp; ENVIRONMENT .....</b>	<b>6</b>
<b>3. PACKAGE CONTENTS.....</b>	<b>7</b>
<b>4. DESCRIPTION &amp; FEATURES.....</b>	<b>8</b>
4.1 VIVO-X8D8 / VIVO-X8.....	8
4.1.1 Main Features.....	9
4.2 BIO-X8G / BIO-X8.....	10
4.2.1 Main Features.....	10
<b>5. INSTALL &amp; CONNECT.....</b>	<b>11</b>
5.1 Location, Assembly and Ventilation.....	11
5.2 Mains Connection.....	11
5.3 VIVO-X8 models and BIO-X8 models interconnection.....	12
5.4 Analogue Input Connections .....	13
5.5 Analogue Output Connections.....	13
5.6 Ethernet Ports (VIVO-X8D8 and VIVO-X8 only) .....	14
5.7 Digital Audio Inputs and Outputs Dante®/AES67 (VIVO-X8D8 only).....	14
5.8 Player and microSD card (VIVO-X8D8 and VIVO-X8 only) .....	15
5.9 GPI Ports (VIVO-X8D8, BIO-X8G and VIVO-X8 only).....	15
5.10 GPO Ports (VIVO-X8D8 and BIO-X8G only).....	16
5.11 RS-232 Remote Control Port (VIVO-X8D8 and VIVO-X8 only).....	16
<b>6. START-UP &amp; OPERATION.....</b>	<b>17</b>
6.1 Start Up .....	17
6.2 First Steps and Operation.....	18
6.2.1 Automatic Connection Using a Computer .....	18
6.2.2 Manual Connection.....	18
6.2.3 Login.....	19
<b>7. PANEL FUNCTIONS.....</b>	<b>20</b>
7.1 VIVO-X8D8 / VIVO-X8.....	20
7.1.1 Front Panel.....	20
7.1.2 Rear Panel.....	21

PRECAUTIONS
WARRANTY & ENVIRONMENT
PACKAGE CONTENTS
DESCRIPTION & FEATURES
INSTALL & CONNECT
START-UP & OPERATION
PANEL FUNCTIONS
TECHNICAL DATA

7.2	VIVO-X8D8, VIVO-X8, BIO-X8G and BIO-X8.....	22
7.2.1	Front Panel.....	22
7.2.2	Rear Panel.....	22
<b>8.</b>	<b>TECHNICAL DATA .....</b>	<b>23</b>
8.1	Technical Specifications.....	23
8.1.1	VIVO-X8D8 / VIVO-X8.....	23
8.1.2	BIO-X8G / BIO-X8.....	26
8.2	Mechanical Diagram.....	28
8.2.1	VIVO-X8D8.....	28
8.2.2	VIVO-X8.....	29
8.2.3	BIO-X8G.....	30
8.2.4	BIO-X8.....	31

PRECAUTIONS
WARRANTY & ENVIRONMENT
PACKAGE CONTENTS
DESCRIPTION & FEATURES
INSTALL & CONNECT
START-UP & OPERATION
PANEL FUNCTIONS
TECHNICAL DATA

# 1. PRECAUTIONS

## 1.1 Important Notice



**WARNING: SHOCK HAZARD - DO NOT OPEN**

**AVIS: RISQUE DE CHOC ÉLECTRIQUE - NE PAS OUVRIR**



The flashing light with an arrowhead symbol inside an equilateral triangle on it is intended to alert the user of the presence of non-insulated “dangerous voltage” within the enclosure, which might be of sufficient magnitude to pose a risk of electric shock to users.



The exclamation mark within an equilateral triangle is intended to alert the user of the requirement for important operating and maintenance (servicing), for which instructions may be found in the literature accompanying the appliance.

**WARNING (If applicable):** Terminals marked with symbol “⚡” may be of sufficient magnitude to pose a risk of electric shock. The external wiring connected to terminals requires installation by a technician, or the use of ready-made leads or cords.

**WARNING:** To prevent fire or shock hazard, do not expose this equipment to rain or humidity.

**WARNING:** A device with Class I manufacturing ought to be connected to a mains socket outlet with a protective earthing connection.



**WARNING:** Ecler products have a long lifetime of more than 10 years. This product must never be discarded as unsorted urban waste, but must be taken to the nearest electrical and electronic waste treatment centre.



**This equipment has been tested and found to comply with the limits of a Class A digital device, pursuant to part 15 of the FCC Rules.** Such limits are designed to provide reasonable protection against harmful interference when the equipment is operated in a commercial environment. This equipment generates, uses and can radiate radio frequency energy and, if not installed and used in accordance with the instruction manual, may cause harmful interference in radio communications. Operation of this equipment in a residential area might cause harmful interference, in which case, the user will be required to correct the interference at his own expense.

	PRECAUTIONS
	WARRANTY & ENVIRONMENT
	PACKAGE CONTENTS
	DESCRIPTION & FEATURES
	INSTALL & CONNECT
	START-UP & OPERATION
	PANEL FUNCTIONS
	TECHNICAL DATA

## 1.2 Key Safety Directions

1. Read the following directions.
2. Keep the following directions.
3. Observe all warnings.
4. Follow all instructions.
5. Do not use this device in proximity to water.
6. Clean only with a dry cloth.
7. Do not block any ventilation openings. Install in accordance with the manufacturer's instructions.
8. Do not install near any heat sources such as radiators, heat registers, stoves, or other devices (including amplifiers) that may release heat.
9. Do not defeat the safety purpose of the polarized or grounding type plug. A polarized plug has two blades, with one being wider than the other. A grounding type plug has two blades and a third grounding prong. The wide blade or the third prong are provided for your safety. If the provided plug does not fit into your outlet, contact a qualified electrician for a replacement of the obsolete outlet.
10. Protect the power cord from being walked on or pinched, particularly at the plugs, convenience receptacles, and at the point of exit from the device.
11. Only use attachments/accessories specified by the manufacturer.
12. Unplug the device during lightning storms or when unused for long periods.
13. Refer all servicing to qualified personnel. Servicing is required when the device has been damaged in any way, such as power supply cord or plug damage, liquid spillage or objects onto the device, the device has been exposed to rain or humidity, does not operate normally, or has been dropped.
14. Disconnecting from mains: When switching off the POWER switch, all the functions and light indicators of the unit will be stopped, but fully disconnecting the device from mains is done by unplugging the power cable from the mains input socket, therefore, it should always remain easily accessible
15. Equipment is connected to a socket-outlet with an earthing connection by means of a power cord.
16. The marking information is located at the top/rear of the unit.
17. The device shall not be exposed to dripping or splashing liquids, and no liquid-filled objects, such as a filled up glass, shall be placed on top of the device.

## 1.3 Cleaning Directions



**Clean the unit with a soft, dry clean cloth** or slightly wet with water and neutral liquid soap only, then dry it with a clean cloth. Be careful that water never gets into the unit through any hole. Never use alcohol, benzine, solvents or abrasive substances to clean this unit.

**NEEC AUDIO BARCELONA, S.L.** accepts no liability for any damage that may be caused to people, animal, or objects due to failure to comply with the warnings above.

	PRECAUTIONS
	WARRANTY & ENVIRONMENT
	PACKAGE CONTENTS
	DESCRIPTION & FEATURES
	INSTALL & CONNECT
	START-UP & OPERATION
	PANEL FUNCTIONS
	TECHNICAL DATA

## 2. WARRANTY & ENVIRONMENT

**Thank you for choosing our VIVO / BIO Series!  
We greatly value your trust.**

It is **VERY IMPORTANT** to carefully read this manual and to fully understand its contents before any connecting takes place in order to make the best use of this equipment, as well as to get the best performance from it.

To ensure optimal operation of this device, **we strongly recommend that its maintenance be carried out by our authorised Technical Services.**

**All ECLER products are covered by warranty**, please refer to [www.ecler.com](http://www.ecler.com) or the warranty card included with this product for the period of validity and conditions.



**Ecler is truly committed with the environment and planet sustainability, energy saving and CO<sub>2</sub> emission reduction.** Recycling materials and using non-contaminant components are also top priorities in our green crusade.

**Ecler has deeply evaluated and analyzed the environmental impacts of all the processes involved in the production of this product, including packaging, and has alleviated, reduced and/or compensated for them.**

PRECAUTIONS
WARRANTY & ENVIRONMENT
PACKAGE CONTENTS
DESCRIPTION & FEATURES
INSTALL & CONNECT
START-UP & OPERATION
PANEL FUNCTIONS
TECHNICAL DATA

### 3. PACKAGE CONTENTS

- **VIVO-X8D8:**

- 1x VIVO-X8D8 unit.
- 1x EU Mains cord.
- 1x Multiplug Mains cord.
- 4x Washers.
- 4x Rubber feet.
- 17x Euroblock connectors (green colour).
- 16x Euroblock connectors (blue colour).
- 2x USB holders.
- 2x Screws.
- First Steps Guide.
- Warranty card.

- **VIVO-X8:**

- 1x VIVO-X8 unit.
- 1x EU Mains cord.
- 1x Multiplug Mains cord.
- 4x Washers.
- 4x Rubber feet.
- 9x Euroblock connectors (green colour).
- 12x Euroblock connectors (blue colour).
- 2x USB holders.
- 2x Screws.
- First Steps Guide.
- Warranty card.

- **BIO-X8G:**

- 1x BIO-X8G unit.
- 1x EU Mains cord.
- 1x Multiplug Mains cord.
- 4x Washers.
- 4x Rubber feet.
- 1x USB-C Ecler X-Link certified cable.
- 16x Euroblock connectors (green colour).
- 16x Euroblock connectors (blue colour).
- 1x USB holder.
- 1x Screw.
- First Steps Guide.
- Warranty card.

- **BIO-X8:**

- 1x BIO-X8 unit.
- 1x EU Mains cord.
- 1x Multiplug Mains cord.
- 4x Washers.
- 4x Rubber feet.
- 1x USB-C Ecler X-Link certified cable.
- 8x Euroblock connectors (green colour).
- 8x Euroblock connectors (blue colour).
- 1x USB holder.
- 1x Screw.
- First Steps Guide.
- Warranty card.

PRECAUTIONS
WARRANTY & ENVIRONMENT
PACKAGE CONTENTS
DESCRIPTION & FEATURES
INSTALL & CONNECT
START-UP & OPERATION
PANEL FUNCTIONS
TECHNICAL DATA

## 4. DESCRIPTION & FEATURES

### 4.1 VIVO-X8D8 / VIVO-X8

VIVO-X8D8 & VIVO-X8 are EclerPLEX Host matrixes.

VIVO-X8D8 features 8 analogue and 8 Dante®/AES67 audio input ports, 8 analogue and 8 Dante®/AES67 audio output ports.

VIVO-X8 features 8 analogue audio input ports and 8 analogue audio output ports.



**Both models are scalable thanks to two X-link ports.** A BIO Series expansion unit can be connected to each X-link port. VIVO Series, performing as a Host unit in an EclerPLEX deployment, can contain multiple projects running simultaneously and serve user control panels to end users.

	PRECAUTIONS
	WARRANTY & ENVIRONMENT
	PACKAGE CONTENTS
	DESCRIPTION & FEATURES
	INSTALL & CONNECT
	START-UP & OPERATION
	PANEL FUNCTIONS
	TECHNICAL DATA

### 4.1.1 Main Features

- EclerPLEX ecosystem host matrix unit.
- 8 MIC / LINE analogue audio input ports (+48V Phantom selectable per port).
- 8 LINE analogue audio output ports.
- 8 Dante®/AES67 digital input ports (4 flows)-VIVO-X8D8 only.
- 8 Dante®/AES67 digital output ports (4 flows)-VIVO-X8D8 only.
- GPI ports: VIVO-X8D8: 8 / VIVO-X8: 4.
- 8 GPO ports (VIVO-X8D8 only).
- 1 microSD card slot (for the 4 players).
- 2x X-link audio&control expansion ports (each port allows to locally connect an external BIO Series expansion unit).
- Scalable up to a 32x32 audio matrix size, including:
  - 24x24 analogue audio ports (by adding 2x BIO-X8 or BIO-X8G units).
  - 24x24 GPI ports (by adding 2x BIO-X8G units).
  - 24x24 GPO ports (by adding 2x BIO-X8G units).
  - 8x8 digital audio ports (Dante®/AES67)-VIVO-X8D8 only.
- 2x Ethernet VIVO-X8D8: NET1 control, NET2 Control + Dante®/AES67 / VIVO-X8: NET1 control, NET2 Control.
- 1x RS-232 control port.
- 1x 1.9” Colour TFT Display.
- Flexible processing structure (allows for custom-size matrix size matrices and custom-DSP power projects).
- Embedded EclerPLEX application that includes:
  - A Workspace, including multiple types of custom-size simultaneous projects running simultaneously, events, calendars, presets and more.
  - An editor, manager and server of User Control Panels
  - Scripting automation & control system.
  - 4 Internal SW audio players.
  - 2 Internal audio generators.
  - EclerCLOUD monitor and control native device.
  - Auto update feature.

 **The hardware is designed to support all the features described in this document. Some are available from version 1.0, while others will be enabled progressively through future software updates.**

	PRECAUTIONS
	WARRANTY & ENVIRONMENT
	PACKAGE CONTENTS
	DESCRIPTION & FEATURES
	INSTALL & CONNECT
	START-UP & OPERATION
	PANEL FUNCTIONS
	TECHNICAL DATA

## 4.2 BIO-X8G / BIO-X8

BIO-X8G and BIO-X8 are cost-effective expansion interfaces designed to seamlessly increase the capacity of an EclerPLEX digital host matrix. Each unit contributes 8 additional analogue audio input ports and 8 analogue audio output ports to the system's default configuration.



The BIO-X8G model further extends functionality by offering 8 GPI ports and 8 GPO ports, enabling advanced control options.

Up to two BIO-X8G or BIO-X8 units can be connected to a single EclerPLEX host matrix, allowing for a maximum configuration of 24 analogue audio input ports, 24 analogue audio output ports, and up to 24x24 GPIO control ports.

### 4.2.1 Main Features

- EclerPLEX audio I/O & control expansion unit, compatible with VIVO host units.
- Connection via X-link to the VIVO host unit (1m Ecler certified X-link cable included).
- Expansion features (added to the host VIVO unit ones):
  - 8 MIC / LINE analogue audio inputs ports (+48V Phantom selectable per port).
  - 8 LINE analogue audio output ports.
  - 8 GPI ports (BIO-X8G only).
  - 8 GPO ports (BIO-X8G only).
- A maximum of 2 BIO-X8G or 2 BIO-X8 units can be connected to a single VIVO host unit, using its 2 x X-link expansion ports.

PRECAUTIONS
WARRANTY & ENVIRONMENT
PACKAGE CONTENTS
DESCRIPTION & FEATURES
INSTALL & CONNECT
START-UP & OPERATION
PANEL FUNCTIONS
TECHNICAL DATA

## 5. INSTALL & CONNECT

### 5.1 Location, Assembly and Ventilation

VIVO and BIO Series units have been specially designed to be installed in 19" rack structure, occupying one unit.

**!** It is very important to ensure that the device is neither enclosed nor exposed to extreme temperatures, as it generates heat. Adequate airflow must be maintained through the ventilation holes in the chassis, with the ventilation system directing the airflow from front to back through the unit.

**!** If multiple devices are installed in the same rack or in a cabinet with closed doors, it is highly recommended to install fans at both the upper and lower ends to create a forced airflow from the bottom up. This upward air flow will help to dissipate the heat generated inside.

**!** Regular maintenance of dust removal is highly recommended to ensure optimal performance as dust can impede airflow and hinder heat dissipation.

### 5.2 Mains Connection

VIVO and BIO Series units operate on alternating voltages ranging from 100 to 240V and 50 to 60 Hz. These devices feature an oversized power supply that can adapt to the mains voltage of any country in the world without requiring any adjustments.

Connect each device to the mains and press the ON/OFF button of the rear panel.



Each device is equipped with a front panel LED indicator that illuminates green when the unit is operational.



PRECAUTIONS
WARRANTY & ENVIRONMENT
PACKAGE CONTENTS
DESCRIPTION & FEATURES
INSTALL & CONNECT
START-UP & OPERATION
PANEL FUNCTIONS
TECHNICAL DATA

### 5.3 VIVO Series and BIO Series interconnection

**!** The BIO Series units require a VIVO Series device to operate, as the VIVO Series units serve as the primary/controller while the BIO Series units work as an expansion unit.

To connect a BIO Series unit to a VIVO Series device, use an Ecler certified USB-C to USB-C cable (supplied with each BIO unit) and connect it to the X-LINK connector located on the rear panel of both devices.



**💡** Each VIVO-X8D8 or VIVO-X8 unit can support up to two BIO Series units.

When the VIVO and BIO Series units are interconnected, the X-LINK LED indicator on the front panel of the BIO Series device illuminates white. It blinks during the synchronization process and remains steadily lit once synchronization is complete and stable.



- PRECAUTIONS
- WARRANTY & ENVIRONMENT
- PACKAGE CONTENTS
- DESCRIPTION & FEATURES
- INSTALL & CONNECT
- START-UP & OPERATION
- PANEL FUNCTIONS
- TECHNICAL DATA

## 5.4 Analogue Input Connections

VIVO-X8D8, VIVO-X8, BIO-X8G and BIO-X8 units each feature 8 balanced analogue signal inputs (IN 1 to 8) on their rear panels, supporting both line and microphone levels. Signal management is handled through the EclerPLEX web interface.

Signal input connectors are Euroblock, type 3 position screw terminal block. The wiring is:

Live or direct signal	→	Pin	+
Cold or inverted signal	→	Pin	-
Ground	→	Pin	⊥

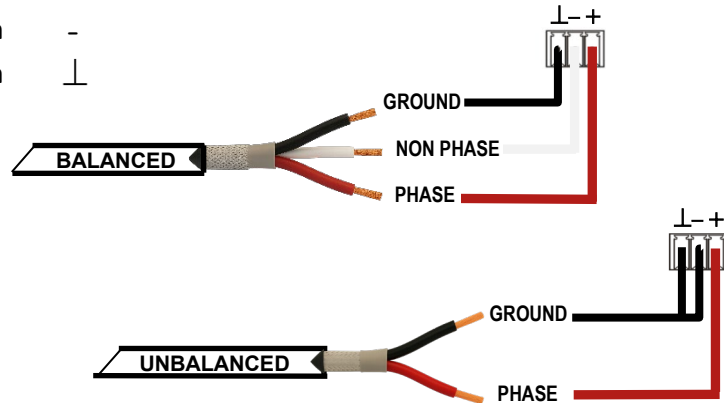

**!** For **unbalanced connection** short-circuit pin ⊥ to pin - as reported on the picture.

## 5.5 Analogue Output Connections

VIVO-X8D8, VIVO-X8, BIO-X8G and BIO-X8 units each feature 8 balanced analogue signal outputs (OUT 1 to 8) with line level.

Signal output connectors are Euroblock, type 3 position screw terminal block. The wiring is:

Live or direct signal	→	Pin	+
Cold or inverted signal	→	Pin	-
Ground	→	Pin	⊥

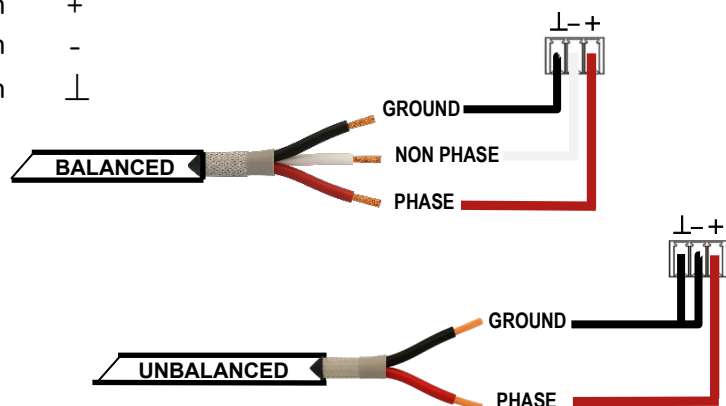

**!** For **unbalanced connection** short-circuit pin ⊥ to pin - as reported on the picture.

- PRECAUTIONS
- WARRANTY & ENVIRONMENT
- PACKAGE CONTENTS
- DESCRIPTION & FEATURES
- INSTALL & CONNECT
- START-UP & OPERATION
- PANEL FUNCTIONS
- TECHNICAL DATA

## 5.6 Ethernet Ports (VIVO-X8D8 and VIVO-X8 only)

VIVO-X8D8 and VIVO-X8 units each feature two RJ-45-type ETHERNET connectors on the rear panel, named NET1 and NET2, which allow the equipment to be connected to an Ethernet network, or directly to a computer or other devices with an Ethernet interface, point-to-point.



1. **NET1 (Control):** WebGUI, user control panels, third party control and other control packages are sent/received over NET1.
2. **NET2:**
  - **VIVOX8D8: (Control + Dante/AES67):** control and Dante/AES67 Audio perform over the same network.
  - **VIVOX8: (Control).**

This connection enables the following within a local network:

- Global programming and management of the VIVO Series unit using the EclerPLEX embedded web application and a standard web browser running on a computer, tablet, etc.
- Connection to Internet for clock synchronization (calendar events), automatic firmware updates, EclerCLOUD platform and other tools.
- Reception of 8 channels of digital Dante/AES67 and sending of 8 channels of digital audio Dante/AES67 (VIVO-X8D8 only).

## 5.7 Digital Audio Inputs and Outputs Dante®/AES67 (VIVO-X8D8 only)

VIVO-X8D8 supports the reception and transmission of 8 channels of digital audio via Dante/AES67 over an Ethernet network, which is compatible with the Dante/AES67 protocol for digital audio over IP.



The routing of digital audio signals via Dante/AES67 through the Ethernet network, along with the configuration of Dante/AES67 network ports (IP addresses, mask, etc.) for the VIVO-X8D8, is managed by the Dante Controller software application.

For further details, please refer to the developer's documentation: [www.audinate.com/products/software/dante-controller](http://www.audinate.com/products/software/dante-controller).

PRECAUTIONS
WARRANTY & ENVIRONMENT
PACKAGE CONTENTS
DESCRIPTION & FEATURES
INSTALL & CONNECT
START-UP & OPERATION
PANEL FUNCTIONS
TECHNICAL DATA

## 5.8 Player and microSD card (VIVO-X8D8 and VIVO-X8 only)

VIVO-X8D8 and VIVO-X8 units each integrate a set of stereo audio players (SW embedded) capable of playing audio files from a local storage device (microSD card), suitable for background music or voice messages. It includes playlist management and integration with the device's calendar events for automation. Customizable user control panels are also available, and the system is fully configurable through the EclerPLEX web application.

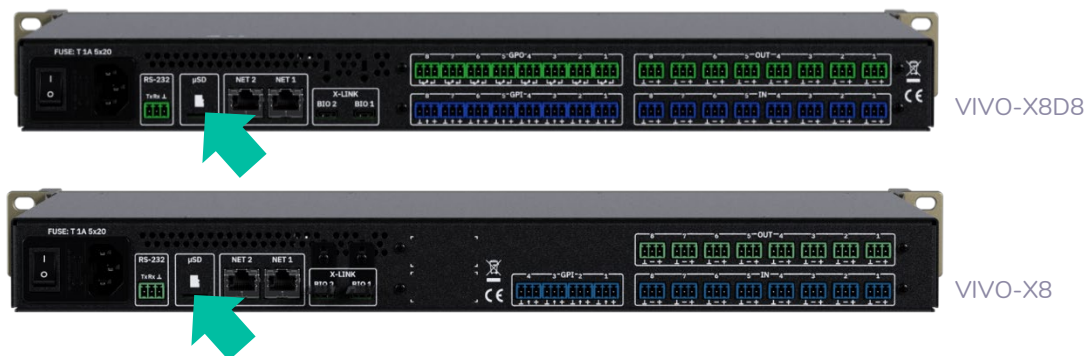

To insert the microSD card, push it into the slot until a click sound is heard. To extract it, push the microSD card inside the slot until a click sound is heard, and it will be released.

## 5.9 GPI Ports (VIVO-X8D8, BIO-X8G and VIVO-X8 only)

The rear panels of the VIVO-X8D8 and BIO-X8G each feature eight 0–12VDC remote control ports labelled “GPI 1–8,” while the VIVO-X8 model includes four ports labelled “GPI 1–4.” These GPI ports enable connection to analogue devices such as WPa and TOCA series wall panels. Using the EclerPLEX web application, functions can be assigned to each of these ports, allowing remote control of the volume of sources, outputs, and local and network groups, including general volume. Additionally, presets or playlists can be loaded.



The GPI connectors are Euroblock type. The assignment of the connection is as follows:

Positive, + 12 VDC	→	Pin	+
Variable voltage, 0-12 VDC	→	Pin	↑
Ground	→	Pin	-

- PRECAUTIONS
- WARRANTY & ENVIRONMENT
- PACKAGE CONTENTS
- DESCRIPTION & FEATURES
- INSTALL & CONNECT
- START-UP & OPERATION
- PANEL FUNCTIONS
- TECHNICAL DATA

## 5.10 GPO Ports (VIVO-X8D8 and BIO-X8G only)

The rear panels of the VIVO-X8D8 and BIO-X8G each feature 8 NO/NC relay outputs (normally open / normally closed). The status of each output can be associated with user presets or events through the EclerPLEX web application, enabling functions such as calendar events or key presses on a user panel. This allows interaction with external equipment, including projection screen motors, movable partition walls, lights, sirens, and GPI inputs from other devices.



## 5.11 RS-232 Remote Control Port (VIVO-X8D8 and VIVO-X8 only)

The RS-232 port, with a Euroblock connector on the rear panel of the VIVO-X8D8 and VIVO-X8 units, allows an external device to communicate with the unit via serial communication. This connection uses the TP-NET protocol syntax allowing the external device to retrieve the value of specific VIVO Series unit parameters using “GET” commands and/or modify these values using “SET” commands.



The serial connection must comply with the following characteristics:

- Baud rate: 115200 (fixed, no auto negotiation)
- Data bits: 8
- Parity: None
- Stop bits: 1
- Flow control: None

PRECAUTIONS
WARRANTY & ENVIRONMENT
PACKAGE CONTENTS
DESCRIPTION & FEATURES
INSTALL & CONNECT
START-UP & OPERATION
PANEL FUNCTIONS
TECHNICAL DATA

## 6. START-UP & OPERATION

### 6.1 Start Up

Connect each device to the AC mains and press the ON/OFF button of the rear panel.

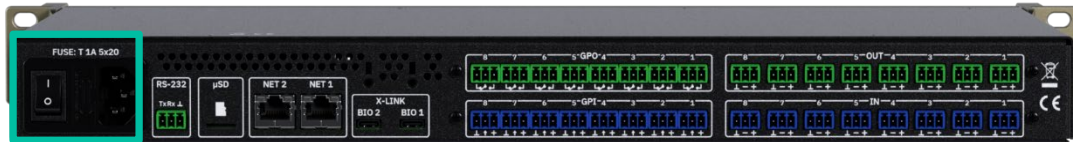

Each device features a front panel LED indicator that lights up when the unit is operational.



	PRECAUTIONS
	WARRANTY & ENVIRONMENT
	PACKAGE CONTENTS
	DESCRIPTION & FEATURES
	INSTALL & CONNECT
	START-UP & OPERATION
	PANEL FUNCTIONS
	TECHNICAL DATA

## 6.2 First Steps and Operation

To access the EclerPLEX web application from an external device (computer, tablet, etc.) using a browser, first make sure both devices are physically connected to the same local network (LAN) and configured within the same network range.

 DHCP is the default network configuration mode. If you have a router/switch with a DHCP server (see the specifications for your device), network configuration is automatic so there is no need to do any re-configuration.

There are two ways to connect to the embedded VIVO host unit web application.

### 6.2.1 Automatic Connection Using a Computer

1. Connect the VIVO Series unit to the router/switch using a CAT5 or higher cable (NET1 or NET2 Ethernet port).
2. Connect your browser equipped device (computer, tablet, etc.) to the same local network (router/switch). You can do this over a wired or WiFi connection, depending on your network device and computer/tablet.
3. Enter into your browser the web address shown on the top panel of the device or on the packaging (<http://vivo-x8-xxxx.local>). The last four digits of the web address correspond to the MAC address of the device.



### 6.2.2 Manual Connection

If you do not have a DHCP server, are unsure whether you have one, or just want to establish a point-to-point connection with a computer:

1. Connect the VIVO Series unit to the computer using a CAT5 cable or higher (NET1 or NET2 Ethernet port).
2. If the VIVO Series unit cannot find a DHCP server, it will be able to connect to an automatic private IP addressing (APIPA) and subnet mask from NET1; the device will select its own IP address in the address range 169.254.1.0 to 169.254.254.255 and will also be reachable via the mDNS service.

3. Otherwise, the device will also remain accessible via the auxiliary IP. Enter NET1 or NET2 IP address in the browser and configure:

- Using NET1:
  - IP: 192.168.0.100
  - Mask: 255.255.255.0
  - Gate: 192.168.0.1
  - UDP Port: 2210
- Or using NET2:
  - IP: 192.168.0.101
  - Mask: 255.255.255.0
  - Gate: 192.168.0.1
  - UDP Port: 2210

### 6.2.3 Login

There are two profiles that can access the app:

1. **Administrator:** An administrator has access to all functions of the VIVO Series devices and can configure any matrix parameter, event, peripherals, etc. An administrator creates users and control panels for the EclerPLEX user app.
2. **User:** users (non-administrator users or end-users of the system) have limited access. The only functions available to normal users are controls (e.g. controlling the volume of an output) but no configuration functions.

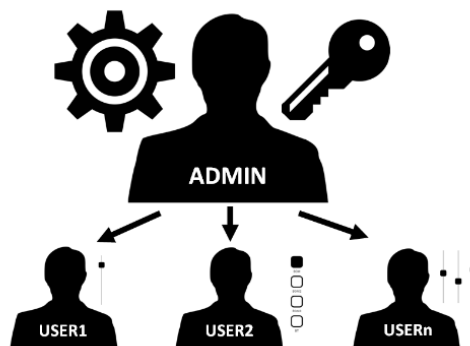

Administrator and user access are password-protected. The default administrator access credentials are:

- **Username:** admin
- **Password:** admin

An administrator can change their access password in the EclerPLEX web app and manage users and passwords.

Usernames and passwords are case-sensitive.

PRECAUTIONS
WARRANTY & ENVIRONMENT
PACKAGE CONTENTS
DESCRIPTION & FEATURES
INSTALL & CONNECT
START-UP & OPERATION
PANEL FUNCTIONS
TECHNICAL DATA

## 7. PANEL FUNCTIONS

### 7.1 VIVO-X8D8 / VIVO-X8

#### 7.1.1 Front Panel

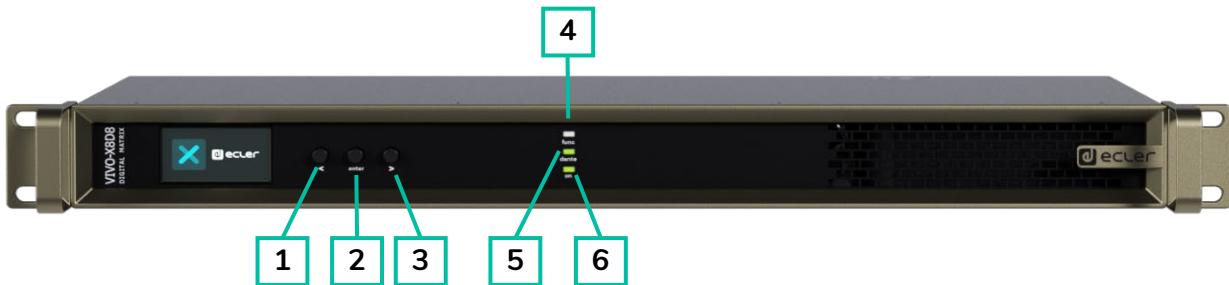

1. **<**: This button allows moving through the display different screens.
2. **Enter**: Enter button.
3. **>**: This button allows moving around the display different screens.
4. **Func LED**: Programable LED. Can be programmed by the user via EclerPLEX.

5. **Dante LED** (VIVO-X8D8 only): Lights up when there is a connection with Dante, according following:

LED colour	Status
Red	PTP error / no PTP sync / PTP disabled
Orange	PTP synchronization in progress.
Green (solid)	PTP follower , with PTP sync
Green (flashing)	PTP leader

6. **On LED**: Lights up in green if the unit is on.



PRECAUTIONS

WARRANTY & ENVIRONMENT

PACKAGE CONTENTS

DESCRIPTION & FEATURES

INSTALL & CONNECT

START-UP & OPERATION

PANEL FUNCTIONS

TECHNICAL DATA

## 7.1.2 Rear Panel

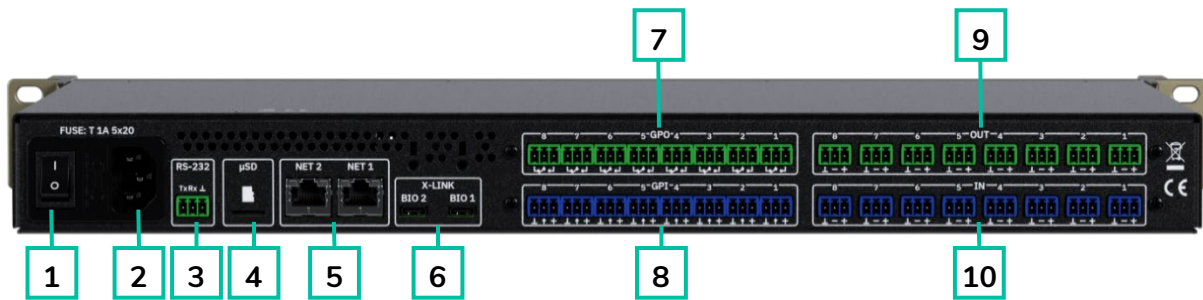

1. **Power Switch:** Unit Power ON switch.
2. **Mains socket base.**
3. **RS-232:** Euroblock connector for remote control via TP-NET protocol, RS-232.
4. **µSD:** microSD card slot.
5. **NET1 / NET2:** RJ-45 ethernet network ports, NET1-2.
6. **X-LINK ports:** USB-C to USB-C connection for one BIO Series model per port.
7. **GPO ports (VIVO-X8D8 only):** 8 GPO ports.
8. **GPI ports:** VIVO-X8D8: 8 ports / VIVO-X8: 4 ports.
9. **OUT (8):** Analogue outputs 1-8, 3-pin Euroblock. Pitch: 3,5 mm.
10. **IN (8):** Analogue inputs 1-8, 3-pin Euroblock. Pitch: 3,5 mm.

	PRECAUTIONS
	WARRANTY & ENVIRONMENT
	PACKAGE CONTENTS
	DESCRIPTION & FEATURES
	INSTALL & CONNECT
	START-UP & OPERATION
	PANEL FUNCTIONS
	TECHNICAL DATA

## 7.2 BIO-X8G / BIO-X8

### 7.2.1 Front Panel

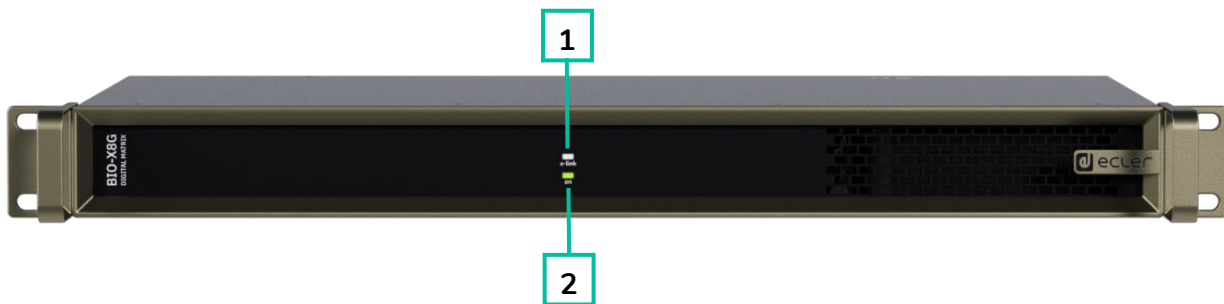

- 1. X-LINK:** When this LED lights white, it indicates active connection with VIVO Series unit. It will blink during the synchronization process and stay continuously lit once the sync is complete and stable.
- 2. On LED:** This LED lights up in green colour if the unit is on.

### 7.2.2 Rear Panel

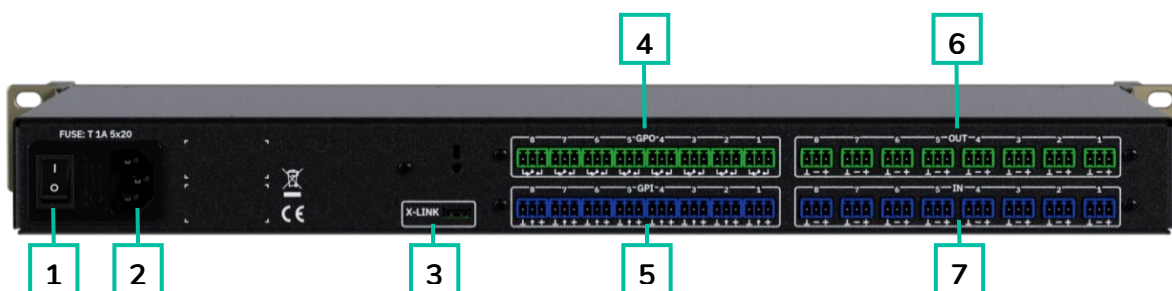

- 1. Power Switch:** Unit Power ON switch.
- 2. Mains socket base.**
- 3. X-LINK:** USB-C to USB-C connection to a VIVO Series unit.
- 4. GPO ports (BIO-X8G only):** 8 GPO ports.
- 5. GPI ports (BIO-X8G only):** 8 GPI ports.
- 6. OUT (8):** Analogue outputs 1-8, 3-pin Euroblock. Pitch: 3,5 mm.
- 7. IN (8):** Analogue inputs 1-8, 3-pin Euroblock. Pitch: 3,5 mm.

PRECAUTIONS
WARRANTY & ENVIRONMENT
PACKAGE CONTENTS
DESCRIPTION & FEATURES
INSTALL & CONNECT
START-UP & OPERATION
PANEL FUNCTIONS
TECHNICAL DATA

## 8. TECHNICAL DATA

### 8.1 Technical Specifications

#### 8.1.1 VIVO-X8D8 / VIVO-X8

##### VIVO-X8 / VIVO-X8D8

DIGITAL ENGINE	
Processor	Quad core 64bits 1,5GHz
AUDIO CONVERTERS	
Sampling rate	48 kHz
Resolution	32 bit
Latency	3.87ms
Frequency response	10Hz to 20kHz (-0,5 dB)
Dynamic range	ADC:115dB, DAC: 115dB
ANALOGUE AUDIO INPUT PORTS	
Number of input ports	8, MIC/LINE level
Connection type	Euroblock, 3-pin, balanced
Input sensitivity	-32,5 dBV to +18,5 dBV -30,3 dBu to +20,7 dBu
Input impedance	8k $\Omega$ (balanced), 4k $\Omega$ (unbalanced)
Max input level	18,5 dBV / 20,7dBu
Mic preamp EIN	<-129,5 dBV <-127,3 dBu
Dynamic range	Gain 0 dB: >110,2 dB Gain 21 dB: >109,5 dB Gain 42 dB: >105,5 dB Gain 51 dB: >99,5 dB
THD + Noise	Gain 0 dB & Vin 0 dBV: 0,0025% Gain 21 dB & Vin -21 dBV: 0,0026% Gain 42 dB & Vin -42 dBV: 0,0044% Gain 51 dB & Vin -51 dBV: 0,0085%
CMRR	Gain 0 dB & Vin +17 dBV: 0,0010% Gain 21 dB & Vin -4 dBV: 0,0015% Gain 42 dB & Vin -25 dBV: 0,0010% Gain 51 dB & Vin -34 dBV: 0,0015% >70dB typ (1kHz) >60 dB typ (20 Hz - 20kHz)
Phantom power	+48VDC, 10mA per input max
ANALOGUE AUDIO OUTPUT PORTS	
Number of output ports	8, LINE level
Connection type	Euroblock, 3-pin, balanced
Max output level	18,5dBV / 20,7dBu
Output impedance	300 $\Omega$ (balanced), 150 $\Omega$ (unbalanced)
Dynamic range	> 112,5 dB
Crosstalk	> 95dB
AUDIO OVER IP	
Protocols	Dante® / AES67 (4/4 flows) - VIVO-X8D8 only.
Number of digital input ports	8 (VIVO-X8D8 only).
Number of digital output ports	8 (VIVO-X8D8 only).
Interfaces	1 x RJ-45 - NET2



PRECAUTIONS

WARRANTY & ENVIRONMENT

PACKAGE CONTENTS

DESCRIPTION & FEATURES

INSTALL & CONNECT

START-UP & OPERATION

PANEL FUNCTIONS

TECHNICAL DATA

CONNECTIVITY		
Ethernet	2, RJ-45 connector NET1 & NET2 (no switch capability) Ethernet Base-Tx 10 /100Mb, 1Gb Auto X-Over	
Serial port	RS-232, Euroblock, 3-pin connector	
Programming and control	EclerPLEX (Web application), TPNET (UDP/RS232), UCP control panels	
X-LINK	2, X-LINK ports. USB-C connector	
REMOTE CONTROL CONNECTIONS		
GPIs	<ul style="list-style-type: none"> <li>VIVO-X8D8: 8, 0 to 12VDC</li> <li>VIVO-X8: 4, 0 to 12VDC</li> </ul>	
GPOs(VIVO-X8D8 only).	8, 3 poles isolated relay; Contact rating: 2A, 30VDC; 0,5A, 125 VAC	
REAL-TIME CLOCK		
RETENTION TIME	> 5 years	
Accuracy	±1 minute / month	
LOCAL STORAGE		
microSD	SDXC	
Capacity	Up to 2TB	
File system	FAT16, FAT 32, VFAT (read/write) NTFS (read) Multi-partition up to 1	
Playable audio files	mp3, ogg, WAV, FLAC, AIFF	
Files analysis	65354 playable folders 65354 playable folders within each folder 65354 playable files within each folder	
Folder hierarchy	Up to 8 containing the root directory	
Sorting	UNICODE, in alphabetical order Up to 100 folders / files by folder Folders/files over 100 sorted in the FAT order	
ELECTRICAL		
Power supply	Internal. Universal, regulated switching mode supply	
AC mains requirement	100-240 VAC @ 50 - 60 Hz	
AC mains connector	IEC C14 inlet	
Power consumption	<ul style="list-style-type: none"> <li>VIVO-X8D8: &lt;19 W Typ, &lt;23,5 W Max &lt;36 VA, &lt;41,5 VA Max</li> <li>VIVO-X8: &lt;16W Standard, &lt;18W Typ, &lt;21,5W Max &lt;32VA Standard, &lt;35,5VA Typ, &lt;42,5VA max</li> </ul>	
Heat load	<65 BTU/h Typ, <80 BTU/h Max	
Ventilation	FAN	
PHYSICAL		
Operating temperature	Min: 0°C / 32°F Max: 50°C / 122°F	
Operating humidity	5 - 85% RH, non-condensing	
Storage temperature	Min: 0°C / 32°F Max: 50°C / 122°F	
Storage humidity	5 - 85% RH, non-condensing	
Installation options	Desktop, 19" racks (1RU)	

PRECAUTIONS
WARRANTY & ENVIRONMENT
PACKAGE CONTENTS
DESCRIPTION & FEATURES
INSTALL & CONNECT
START-UP & OPERATION
PANEL FUNCTIONS
TECHNICAL DATA

Included accessories	<ul style="list-style-type: none"> <li>▪ VIVO-X8D8: 1x EU Mains cord, 1x Multiplug Mains cord, 4x Washers, 4x Rubber feet, 17x Euroblock connectors (green colour), 16x Euroblock connectors (blue colour), 2 USB holders, 2x Screws.</li> <li>▪ VIVO-X8: 1x EU Mains cord, 1x Multiplug Mains cord, 4x Washers, 4x Rubber feet, 9x Euroblock connectors (green colour), 12x Euroblock connectors (blue colour), 2 USB holders, 2x Screws.</li> </ul>
Dimensions (WxHxD)	482.4 x 44 x 214 mm / 18.99 x 1.73 x 8.43 in.
Weight	<ul style="list-style-type: none"> <li>▪ VIVO-X8D8: 3.2 kg / 7.05 lb</li> <li>▪ VIVO-X8: 3.2 Kg / 7.05 lb.</li> </ul>
Shipping dimensions (WxHxD)	585 x 385 x 75 mm / 23.03 x 15.15 x 2.95 in.
Shipping weight	<ul style="list-style-type: none"> <li>▪ VIVO-X8D8: 4.65 kg/ 10.25 lb</li> <li>▪ VIVO-X8: 4.65 kg / 10.25 lb.</li> </ul>

PRECAUTIONS
WARRANTY & ENVIRONMENT
PACKAGE CONTENTS
DESCRIPTION & FEATURES
INSTALL & CONNECT
START-UP & OPERATION
PANEL FUNCTIONS
TECHNICAL DATA

## 8.1.2 BIO-X8G / BIO-X8

### BIO-X8 / BIO-X8G

AUDIO CONVERTERS	
Sampling rate	48 kHz
Resolution	32 bit
Latency	3.87ms
Frequency response	10Hz to 20kHz (-0,5 dB)
Dynamic range	ADC:115dB, DAC: 115dB
ANALOGUE AUDIO INPUT PORTS	
Number of input ports	8, MIC/LINE level
Connection type	Euroblock, 3-pin, balanced
Input sensitivity	-32,5 dBV to +18,5 dBV -30,3 dBu to +20,7 dBu
Input impedance	8k $\Omega$ (balanced), 4k $\Omega$ (unbalanced)
Max input level	18,5 dBV / 20,7dBu
Mic preamp EIN	<-129,5 dBV <-127,3 dBu
Dynamic range	Gain 0 dB: >110,2 dB Gain 21 dB: >109,5 dB Gain 42 dB: >105,5 dB Gain 51 dB: >99,5 dB
THD + Noise	Gain 0 dB & Vin 0 dBV: 0,0025% Gain 21 dB & Vin -21 dBV: 0,0026% Gain 42 dB & Vin -42 dBV: 0,0044% Gain 51 dB & Vin -51 dBV: 0,0085%
CMRR	Gain 0 dB & Vin +17 dBV: 0,0010% Gain 21 dB & Vin -4 dBV: 0,0015% Gain 42 dB & Vin -25 dBV: 0,0010% Gain 51 dB & Vin -34 dBV: 0,0015%
Phantom power	>70dB typ (1kHz) >60 dB typ (20 Hz - 20kHz) +48VDC, 10mA per input max
ANALOGUE AUDIO OUTPUT PORTS	
Number of output ports	8, LINE level
Connection type	Euroblock, 3-pin, balanced
Max output level	18,5dBV / 20,7dBu
Output impedance	300 $\Omega$ (balanced), 150 $\Omega$ (unbalanced)
Dynamic range	> 112,5 dB
Crosstalk	> 95dB
CONNECTIVITY	
X-LINK	1, X-LINK port. USB-C connector
REMOTE CONTROL CONNECTIONS	
GPIs	8, 0 to 12VDC (BIO-X8G only).
GPOs (BIO-X8G only).	8, 3 poles isolated relay; Contact rating: 2A, 30VDC; 0,5A, 125 VAC
ELECTRICAL	
Power supply	Internal. Universal, regulated switching mode supply
AC mains requirement	100-240 VAC @ 50 - 60 Hz
AC mains connector	IEC C14 inlet

PRECAUTIONS
WARRANTY & ENVIRONMENT
PACKAGE CONTENTS
DESCRIPTION & FEATURES
INSTALL & CONNECT
START-UP & OPERATION
PANEL FUNCTIONS
TECHNICAL DATA

Power consumption	<ul style="list-style-type: none"> <li>▪ BIO-X8G: &lt;16 W Typ, &lt;20 W Max &lt;30 VA, &lt;36,3 VA Max</li> <li>▪ BIO-X8: &lt;13W Standard, &lt;15W Typ, &lt;18,5W Max &lt;26VA Standard, &lt;30,5VA Typ, &lt;36,5VA Max</li> </ul>
Heat load	<54,6 BTU/h Typ, <68,2 BTU/h Max
Ventilation	FAN
<b>PHYSICAL</b>	
Operating temperature	Min: 0°C / 32°F Max: 50°C / 122°F
Operating humidity	5 - 85% RH, non-condensing
Storage temperature	Min: 0°C / 32°F Max: 50°C / 122°F
Storage humidity	5 - 85% RH, non-condensing
Installation options	Desktop, 19" racks (1RU)
Included accessories	<ul style="list-style-type: none"> <li>▪ BIO-X8G: 1x EU Mains cord, 1x Multiplug Mains cord, 4x Washers, 4x Rubber feet, 1x USB-C Ecler X-Link certified cable, 16x Euroblock connectors (green colour), 16x Euroblock connectors (blue colour), 1x USB holder, 1x Screw.</li> <li>▪ BIO-X8: 1x EU Mains cord, 1x Multiplug Mains cord, 4x Washers, 4x Rubber feet, 1x USB-C Ecler X-Link certified cable, 8x Euroblock connectors (green colour), 8x Euroblock connectors (blue colour), 1x USB holder, 1x Screw.</li> </ul>
Dimensions (WxHxD)	482.4 x 44 x 214 mm / 18.99 x 1.73 x 8.43 in.
Weight	<ul style="list-style-type: none"> <li>▪ BIO-X8G: 3.0 kg / 6.61 lb</li> <li>▪ BIO-X8: 3.0 kg / 6.61 lb.</li> </ul>
Shipping dimensions (WxHxD)	585 x 75 x 385 mm / 23.03 x 2.95 x 15.15 in.
Shipping weight	<ul style="list-style-type: none"> <li>▪ BIO-X8G: 4.45 kg/ 9.81 lb</li> <li>▪ BIO-X8: 4.45 kg/ 9.81 lb</li> </ul>

PRECAUTIONS
WARRANTY & ENVIRONMENT
PACKAGE CONTENTS
DESCRIPTION & FEATURES
INSTALL & CONNECT
START-UP & OPERATION
PANEL FUNCTIONS
TECHNICAL DATA

## 8.2 Mechanical Diagram

### 8.2.1 VIVO-X8D8

All measurements are in mm.

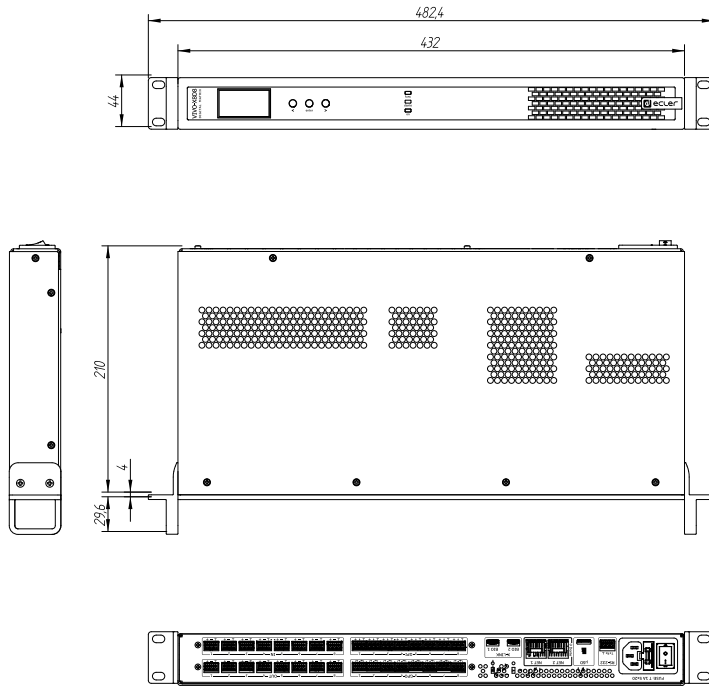

Ecler VIVO-X8D8 Mechanical Diagram

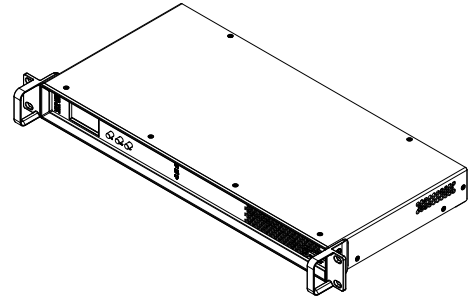

All the measurements are in mm

61-1141-0200

[www.ecler.com](http://www.ecler.com)

	PRECAUTIONS
	WARRANTY & ENVIRONMENT
	PACKAGE CONTENTS
	DESCRIPTION & FEATURES
	INSTALL & CONNECT
	START-UP & OPERATION
	PANEL FUNCTIONS
	TECHNICAL DATA

## 8.2.2 VIVO-X8

All measurements are in mm.

Ecler VIVO-X8 Mechanical Diagram

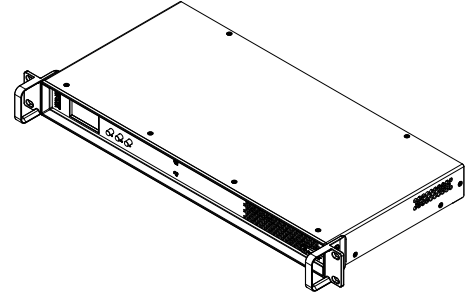
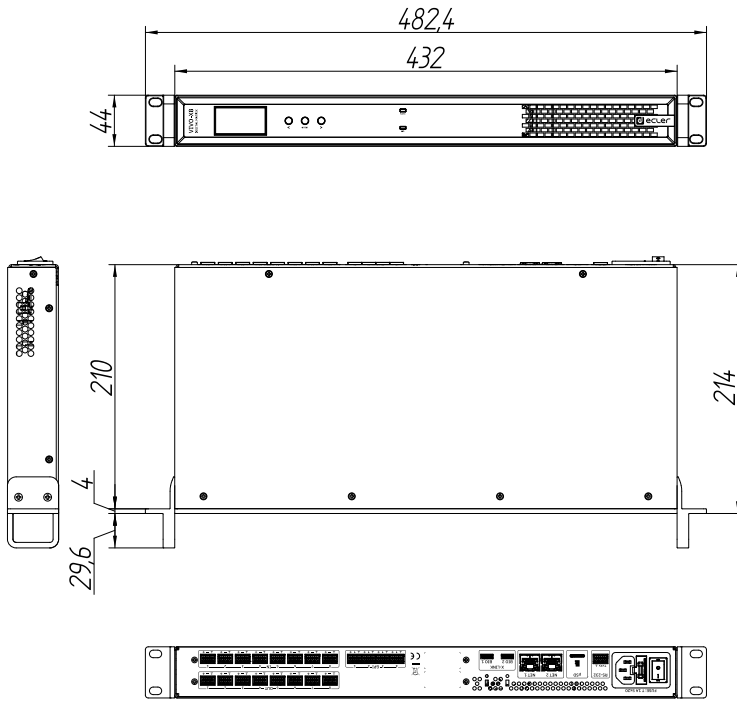

All the measurements are in mm

61-1186-0100

[www.ecler.com](http://www.ecler.com)

PRECAUTIONS
WARRANTY & ENVIRONMENT
PACKAGE CONTENTS
DESCRIPTION & FEATURES
INSTALL & CONNECT
START-UP & OPERATION
PANEL FUNCTIONS
TECHNICAL DATA

### 8.2.3 BIO-X8G

All measurements are in mm.

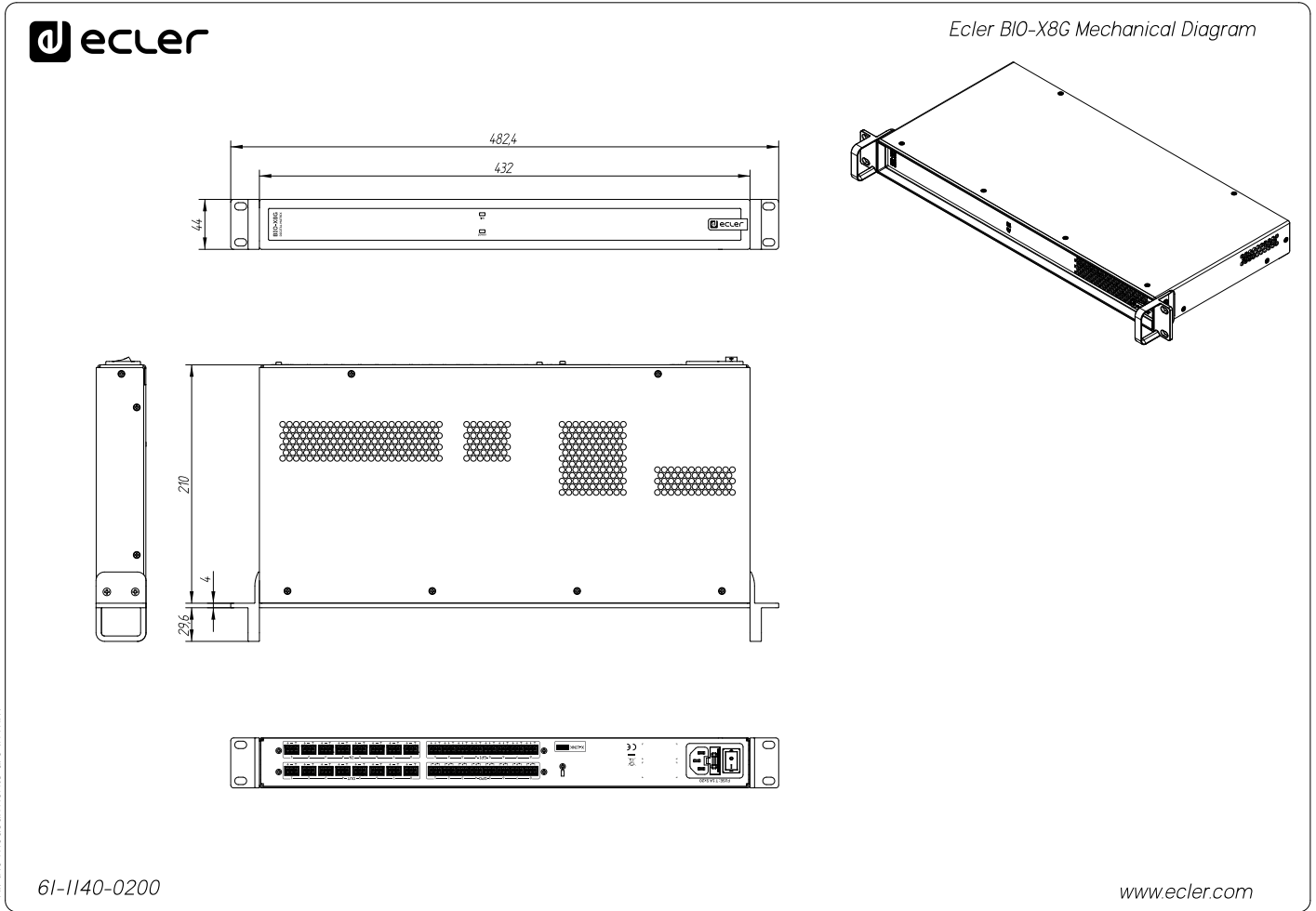

All the measurements are in mm.

PRECAUTIONS
WARRANTY & ENVIRONMENT
PACKAGE CONTENTS
DESCRIPTION & FEATURES
INSTALL & CONNECT
START-UP & OPERATION
PANEL FUNCTIONS
TECHNICAL DATA

## 8.2.4 BIO-X8

All measurements are in mm.

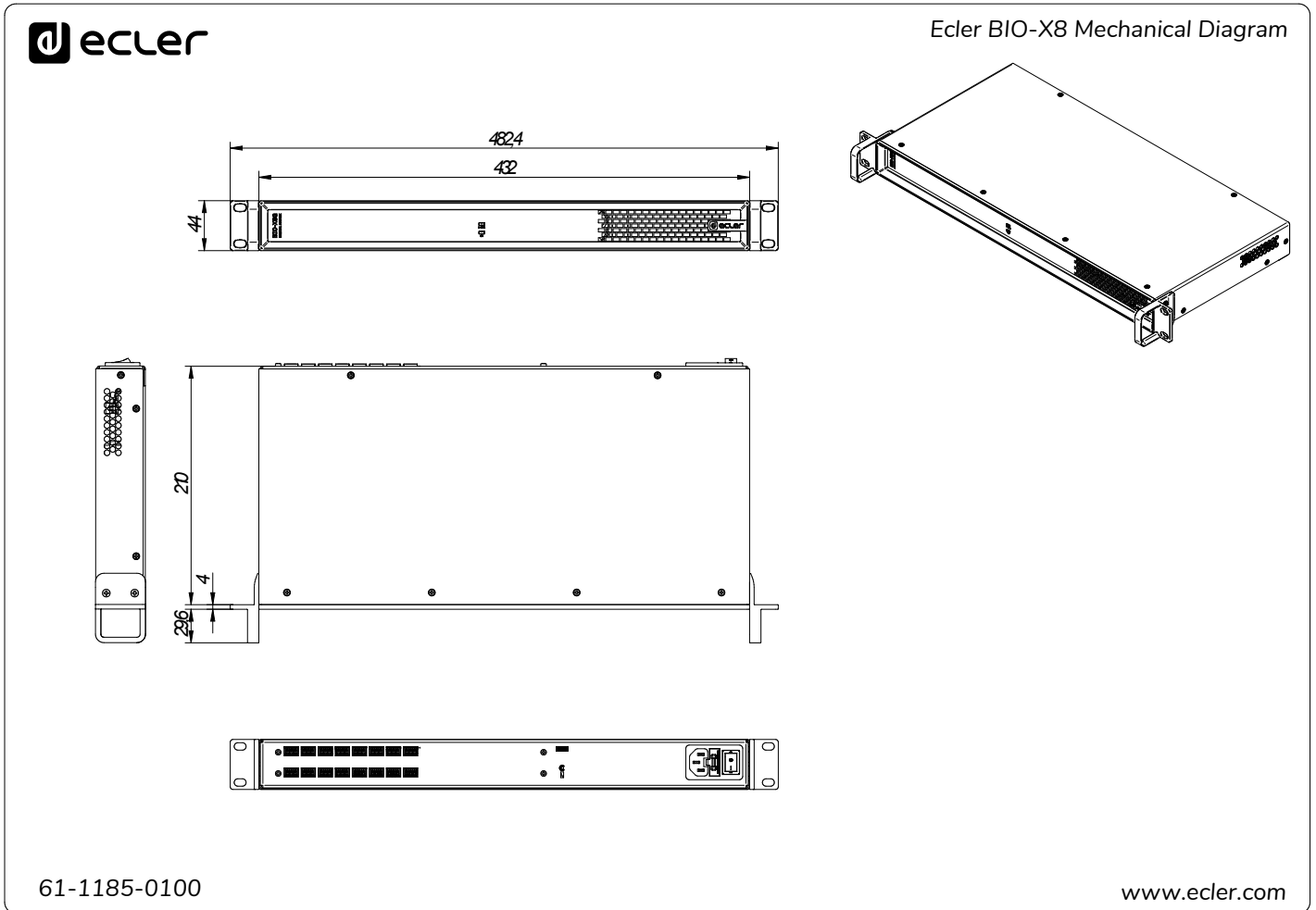

All the measurements are in mm

PRECAUTIONS
WARRANTY & ENVIRONMENT
PACKAGE CONTENTS
DESCRIPTION & FEATURES
INSTALL & CONNECT
START-UP & OPERATION
PANEL FUNCTIONS
TECHNICAL DATA

PRECAUTIONS
WARRANTY & ENVIRONMENT
PACKAGE CONTENTS
DESCRIPTION & FEATURES
INSTALL & CONNECT
START-UP & OPERATION
PANEL FUNCTIONS
TECHNICAL DATA